

CQ-TV

Issue 241 September 2013
ISSN 1466-6790

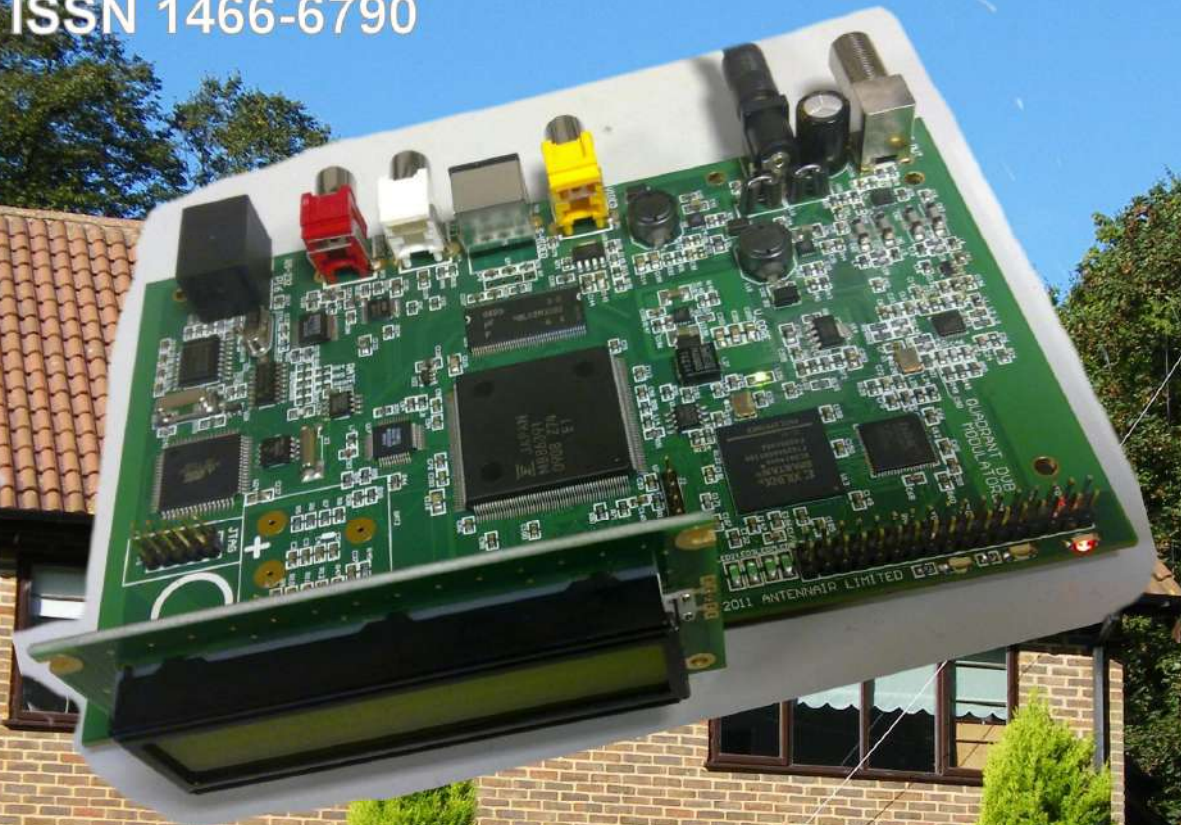

Quadrant

DVB

BATC DTX1 DVB-S
1000.0MHz [>69]+



A N T E N N A I R



**DTX1 Multiband Digital TV
transmitter from the BATC shop**

VHF

COMMUNICATIONS MAGAZINE



A publication for the radio amateur worldwide, especially covering VHF, UHF and Microwaves



VHF Communications is a quarterly magazine only available by subscription. The subscription for 2013 is £22.80 which includes UK postage. Surface mail for overseas subscribers is an additional £3.00 and airmail postage is available at £5.00 for European subscribers and £8.00 for those outside Europe.

For more information or to subscribe contact us at the address below or visit www.vhfcomm.co.uk The web site has sample articles and a full index from 1969 to the present that can be searched to find articles.

Back issues are available as printed magazines or photocopies, most are £1.00 each. There is a full list on the web site.

Back issues are also available as pdf files on data DVDs. There are five different DVDs available:

- **1970s** all magazines from 1969 to 1979 for £20.00 plus postage
- **1980s** all magazines from 1980 to 1989 for £20.00 plus postage
- **1990s** all magazines from 1990 to 1999 for £20.00 plus postage
- **2000s** all magazines from 2000 to 2009 for £35.00 plus postage
- **Bumper** all magazines from 1969 to 2009 for £85.00 plus postage

WIN €150 WORTH OF COMPONENTS BY WRITING AN ARTICLE FOR THE 2013 MAGAZINE (FOR DETAILS SEE WEB SITE)

K M Publications, 503 Northdown Road, Margate, Kent, CT9 3HD, UK. Tel/Fax: +44 (0) 1843 220080, email: andy@vhfcomm.co.uk

Wanted

The BATC is run and managed by its committee. These are voluntary positions, expenses are paid. Many of the committee members have helped run the club for a large number of years.

If you have the skills and the interest to join the BATC committee then we would be pleased to hear from you. We are specifically looking for committee members shown here but assistance at all levels would be welcome.

Please contact any committee member or email: memsec@batc.org.uk

CQ-TV Editor

The club is noted for its interesting and well presented quarterly printed magazine, and more recently the cyber version. To maintain this we need a new editor.

If you have an interest in magazine layout, a modest technical understanding of the hobby and are possibly familiar with Adobe InDesign layout software we would be very pleased to hear from you.

Unfortunately without a new Editor we won't be able to publish all 4 editions of CQ-TV each year.

Webmaster

The club has two main web sites. One for the club management and information including the forum. Another for video streaming.

If you have an interest and the skills to create or manage web sites we would be pleased to hear from you. A knowledge of html and support software is essential in order to be able to quickly implement any changes.

Contents

Committee Contacts-----	4
From the Chairman-----	5
Repeater News-----	6
BBC BH and Paul Marshall-----	6
Overseas News-----	7
Don Reid-----	7
Contest News-----	8
DTX1 advertisement-----	9
An Introduction to the DTX1 Transmitter-----	10
DTX1 1 st User Review-----	11
Standardising PID's for DATV -----	11
PGA103+ Broad Band Amplifier-----	12
CAT13 – the BATC 2013 Convention details-----	15
BATC Presentation for DXSpot.v-----	16
DxSpot.tv details and information-----	17
BATC Treasurers Report for 2012-----	18
50 years of home video recording-----	20
FPGA programming for beginners. Part 1-----	21
BATC Training – the Digital Studio part 2-----	24
Setting up a Virtual Studio-----	30
History of Television – Monoscope Cameras-----	36
GB3IV Repeater-----	38
A new approach to Digital ATV repeaters in New Zealand-----	40
DATV from the International Space Station – full specification-----	44
BATC activities-----	48

Copyright © by the BATC and contributors.

Legal Niceties (the small print)

E&OE. Whilst every care is taken in the production of this publication, the editor accepts no legal responsibility for the advice, data and opinions expressed. The BATC neither endorses nor is it responsible for the content of advertisements or the activities of those advertisers. No guarantee of accuracy is implied or given for the material herein. The BATC expressly disclaims all liability to any person in respect of anything and in respect of the consequences of anything done or omitted to be done wholly or partly in reliance upon the whole or any part of this magazine.

As the regulations for the operation of radio frequency equipment vary in different countries, readers are advised to check that building or operating any piece of equipment described in CQ-TV will not contravene the rules that apply in their own country. The contents of this publication are covered by international copyright and must not be reproduced without permission, although an exception is made for not-for-profit publications (only) wishing to reprint short extracts or single articles and then only if acknowledgment is given to CQ-TV.

Apart from any fair dealing for the purposes of published review, private study or research permitted under applicable copyright legislation, no part of this publication may be reproduced, stored in a retrieval system or transmitted in any form or by any means, electronic, mechanical, photocopy, recording or otherwise, without the prior permission of the publisher. All copyrights and trademarks mentioned in this publication are acknowledged and no infringement of the intellectual copyright of others is intended. Printed in Great Britain. ISSN 1466-6790

Notice to Contributors

Authors are alone responsible for the content of their articles, including factual and legal accuracy, and opinions expressed by them may not reflect the editorial stance of the publication. Material submitted to CQ-TV should not infringe the copyright of other writers or bodies. Articles remain the copyright of their authors and following publication in CQ-TV, they may also appear on the BATC's web site and CD-ROMs, also in other not-for-profit amateur publications. Contributions are accepted for publication on this basis alone.



President: Peter Blakeborough, G3PYB
Email: president@batc.org.uk

Chairman: Noel Matthews, G8GTZ
Club affairs and Technical queries. ETCC Liason.
Email: chairperson@batc.org.k

General Secretary: David Mann, G8ADM
General club correspondence and business.
Email: secretary@batc.org.uk

Hon. Treasurer: Brian Summers, G8GQS
Enquiries about club finances, donations,
Club Constitution.
Email: treasurer@batc.org.uk

Membership: David Mann, G8ADM
All membership enquiries including new
applications, current membership, non
receipt of CQ-TV, subscriptions.
Email: memsec@batc.org.uk

IT support: Chris Smith G1FEF
Anything to do with the BATC computer
system including live video streaming.
Email: tech@batc.org.uk

Contests: Dave Crump, G8GKQ
Email: contests@batc.org.uk

CQ-TV Editor: David Mann, G8ADM
and Noel Matthews, G8GTZ
Email: editor@batc.org.uk

Shop / Members Services:
Noel Matthews, G8GTZ
Email: shop@batc.org.uk

CQ-TV Advertising: David Mann, G8ADM
Email: adman@batc.org.uk

BATC Webmaster: Noel Matthews, G8GTZ
Anything to do with the BATC web sites.
Email: webmaster@batc.org.uk

Club Liaison: Graham Shirville, G3VZV
Anything of a political nature.
Email: g3vzv@amsat.org

Deadlines

The preferred method of communication is by email, all email addresses are shown above.

You can also telephone 01400 414 243
You will then hear a menu that will allow you to be connected to the correct person if they are available.

Alternatively you can write to us at:

BATC
Silverwood
South View Road
Pinner
HA5 3YA
United Kingdom

We aim to publish CQ-TV quarterly in February, May, August and November. The deadlines for each issue are:

February	-	Please submit by December 31 st
May	-	Please submit by March 31 st
August	-	Please submit by June 30 th
November	-	Please submit by September 30 th

Please send your contributions in as soon as you can prior to this date. Don't wait for the deadline if you have something to publish as the longer we have your article, the easier it is for us to prepare the page layouts. If you have pictures that you want including in your article, please send them, in **the highest possible quality**, as separate files. Pictures already embedded in a page are difficult to extract at high quality but if you want to demonstrate your preferred layout, a sample of your finished work with pictures in place is welcomed. Please note the implications of submitting an article which are detailed on the contents page.

From the Chairman

From Noel, Matthews G8GTZ

Well, a lot has happened since the last edition of CQ-TV. We've had the Ofcom consultation, no feedback yet but we are expecting an update in the next few weeks, we've launched DXspot.tv, we had 400 people watching the launch of a Raspberry PI balloon flight on the BATC streamer, the initial tests for the ISS HAMTV using the streamer have been successfully completed and we've had some good weather but the lift promised by Hepburn never really materialised!

The big news this time round is the launch of the BATC DTX1 digital encoder and modulator developed specifically for ATV use on 70 and 23cms. It is designed and manufactured in the UK for the BATC by Antennair in Manchester and although based on their consumer product, it has special ATV software and is only available through the BATC shop. Mark G4WVU and keeper of GB3TN has been evaluating a unit for some time and his independent review is included in this issue of CQ-TV along with a more detailed description and pictures of the unit.

We see this as an important step for BATC in supporting its members and ATV repeater groups by making DATV equipment more accessible and sales will initially be limited to members only.

As mentioned above, www.dxspot.tv has launched and saw intense use during the contest and moderate lift conditions in June. In order to recognise the initiative and work put in by Phil Crump (MODNY) to launch the site we have decided to give him the first of an occasional grant that the BATC committee will award to recognise when someone is doing good work to further the cause of the ATV community.

If you know of someone, or a team of people, who have gone beyond the norm to support and promote ATV, please nominate them for an award by emailing me or any other committee member.

In my last column I said the committee had decided not to progress with the move to BATC Ltd. I am now pleased to report that we have taken that decision further and have agreed on behalf of the club to buy back the assets of BATC Ltd and also take over full control of the hosting and administration of our websites. It is only right that the members of the club have full control of the very successful video streaming portal.

We are currently in process of putting together a team to look at developing the next generation BATC web site and streamer. If you are interested and can help with graphic and website design or coding please contact us. As part of this,

you may have noticed the new BATC logo which will be adopted across all our sites and publications to help give the BATC a modern and recognisable image.

The next big thing is of course, CAT13 at Finningley on October 26th and 27th – we've got a full agenda with talks, demos, test equipment and the opportunity to buy, build and test an SMD project and it will be a great opportunity to meet all those other ATVer's who you only normally talk to on 144.750. More details and up to news is available on the BATC forum.

There's a lot going on at BATC, which is so much more than just a magazine, to help and support the worldwide ATV community but we really do need more people to help – several committee members are multi-tasking and whilst we can do this in the short term, we are afraid that the quality of what we can offer to our members will suffer in the long term.

If you feel you can help to run your club, please get in touch and in the meantime for all the latest and up to date ATV news don't forget to visit the BATC forum.

INTERESTED IN VINTAGE TECHNOLOGY ?

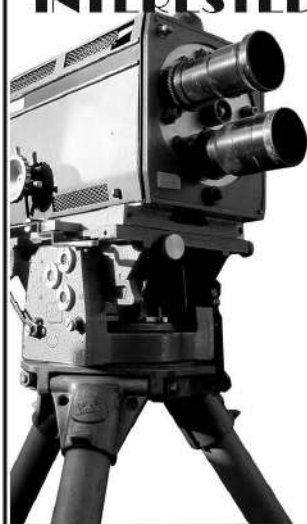

Subscribe to AIRWAVES

The bi-monthly catalogue magazine for vintage technology enthusiasts. Contains items for sale, plus articles on the history and restoration of old equipment.

Send an A5 S.A.E for free sample copy and subscription details to:

On The Air

**The Vintage Technology Centre
Th Highway, Hawarden
(Nr. Chester) CH53DN**

Tel: 01244 530300

Email: info@vintageradio.co.uk

Website: www.vintageradio.co.uk

**❖ WIRELESS
❖ TELEVISION
❖ GRAMOPHONES
❖ AUDIO & VIDEO
❖ STUDIO EQUIPMENT**



Repeater News

Despite the date, 4 repeater groups received their long awaited new licences, NoV's, on Friday 13th September.

This means the following groups now have a license to operate:

GB3FY – Fleetwood - 10 GHz, 3 cm band

GB3SQ – Bournemouth – 1.3 GHz, 23 cm band

GB3BH – Watford – 3.4 GHz, 6 cm band

GB3KM - County Durham – 3.4 GHz, 6 cm band

GB3BA – Hampshire – 3.4 GHz, 6 Cm received it's NOV earlier in the year.

GB3KM, GB3BH and GB3BA are now licensed for operation on 3.4 GHz, a new band for ATV repeaters in the UK. The BATC shop will be stocking C band LNBs to enable reception of the repeaters with a standard DATV receiver.

HM Queen opens the BBC's New Broadcasting House

The BBC's huge new extension to the old Broadcasting House ('BH' in BBC speak) was opened on the 7th June by the Queen. Former BATC General Secretary Paul Marshall was there with a Marconi MkII Image Orthicon camera (pictured) which was used at the 1953 Coronation. This camera is familiar to many as the one featured on the BBC's Sports Personality of the Year trophy. It is the classic British 4-lens turret camera of the early 1950s and was the mainstay for Outside Broadcast operations. The example shown spent some 20 years on a rubbish tip in Essex and has now reached a stage in its restoration where it can be seen in public! There's still much to do to achieve operational status but this is now a real target. The Queen was shown the camera in the presence of the man in charge of the BBC's Coronation coverage, Peter Dimmock and the television presenter Sylvia Peters. Paul was also lucky enough to be introduced to Her Majesty as the leader of Project Vivat which is dedicated to recreating an early 1950s Outside Broadcast Unit, or 'scanner van', as they were then known. See: www.projectvivat.co.uk for more information.

The Marconi MkII Camera

After the Second World War, the Marconi Company dissolved its partnership in television with EMI.

It then began its own independent manufacture of television cameras through its historic relationship with RCA in the United States of America.

This led to the introduction in 1948 of a British version of the RCA TK30 camera using the very complex, but very sensitive, Image Orthicon camera tube.

This high sensitivity made it ideal for low-light conditions as often found on outside broadcasts. The American design was improved and adapted for British manufacture and by 1950 the Marconi MkII was being produced in small quantities at the company's principal facility in Chelmsford, Essex. These were, of course, very expensive hand-built items and each would have cost the equivalent of a new house.

Between 1950 and 1955 around 110 of these cameras were made in Chelmsford. Approximately half that number sold in the United Kingdom (mainly to the BBC), with the balance exported around the world as the deployment of broadcast television services spread.

By the standards of the time, the camera offered excellent pictures in all light conditions, coupled with high reliability and versatility.

When adapted to use the new zoom lens technology developed in the United Kingdom by companies such as Watson & Son of Barnet, it represented the 'state of the art' in television technology and a showcase for British television engineering.

In 1952, with HM the Queen's Coronation approaching in the following year, it was not surprising that the Marconi MkII camera became the bedrock of the BBC's engineering response to the needs of its planned television coverage.



Paul with his MkII Marconi Camera

Overseas News

By Dave Crump

In this new feature for CQ-TV, I will be reporting on what is going on in the amateur TV scene overseas. Sadly, there is no ATV activity in Abu Dhabi where I am currently living, so I'll be casting my net far and wide.

Japan

Shozo Kurita, JA6GBR, has described his new Transverter for 47 GHz ATV in the latest DUBUS Magazine. Using a novel division/multiplication approach, he achieves 25 mw output at 47 GHz from a Khune 23-47S varactor multiplier. Best DX so far is a 2-way contact with JA6BLS over 32 km. The exciter is a conventional DATV transmitter-receiver system built for 1.28 GHz. The block diagram is shown below.

Shozo reports that the transverter works well with both FM and QPSK ATV.

The Netherlands

The ATV Columns in Electron, VERON's magazine, report some valiant efforts during recent ATV contests with portable stations equipped with 6cm, 3cm, and 1.2cm equipment.

DATV is clearly taking off in the Netherlands, using similar standards to those proposed by the BATC. Keep an eye out for Dutch stations on DXspot.tv, as details of the website were also published in Electron.

Electron also brings reports of a new plug-in for SDR# called TVSharp, which allows the RTL dongles (as presented at the BATC BGM) to receive low bandwidth analogue AM TV transmissions. The received bandwidth is only a few MHz, so there will not be any colour or fine detail displayed, but it should provide a good way to receive the 70cm low-bandwidth analogue TV transmissions still used in some parts of Europe. The latest version was available for download from <http://sdrts.amoti.ru/download/view.download/4/8> at the time of writing.

VERON run an ATV Contest on the same weekend as the BATC Summer Fun contest and report that they had 22 Entries on all bands except 9cm from 70cm to 1.2cm. The 70cm activity was all on AM using receive bandwidths as low as 700 kHz.

John, PD2PRT reports that the repeater PI6HVS has inputs on 5 bands and outputs on 13 cm and 3 cm. Take a look at this ambitious project: www.pi6hvs.nl

France

Keep an eye on the French ATV WebSite <http://www.anta-asso.fr> to see what is going on in France – we hope to bring you more from their "B5" magazine in the future.

Australia

The ATV QSO Party held on 30 August is becoming a regular event. Organised around the Melbourne ATV Group repeaters, VK3RTV about 20 Australian amateurs sent pictures to the repeater via RF and others from overseas via Skype. The whole event was relayed by the W6ATN repeater from www.batc.tv. More details - see the VK3RTV-1 display on www.batc.tv repeaters.

Next Time

In the next issue, I'll focus on what is going on with ATV in the USA

Don Reid

We are sad to announce the death of Don Reid, who died on July 13th, 2013 at the age of 81.

Don had been a member of the BATC since 1954 and was a friend of Mike Barlow who founded the club in 1949. Don was Assistant Secretary of the BATC and CQ-TV Editor until 1958, in which year he also organised the BATC Convention, and from 1958 to 1962 he was Hon Secretary. From 1968 to 1970 he was club Public Relations Officer and was club Chairman from 1974 to 1980. He remained on the committee until 1988.

Don did much to help develop the club in the early days and he remained an enthusiastic member throughout his life.

In the 1960s Don worked for Marconi in Chelmsford. In 1962 he went to Sierra Leone to help run their television network and later moved to Nigeria until the start of the Civil War.

Don, a quiet, likeable man, became ill soon after he retired. His wife, Janet,

says he never complained about his illness and remained interested in television technology until his death, he always looked forward to receiving CQ-TV.

We have received many tributes to Don, from Trevor Brown, Mike Cox, Peter Delaney, Graham Shirville, Brian Summers, Ian Waters and Dave Mann.

Don will be sadly missed, and we send our sincere sympathy to Janet and family

Don at the 1968 BATC Convention >>>



Contest News

Summerfun Contest 2013. Results.

70cm

Pos	Call	Locator	QSOs	Points	Best DX	QTH	QRB
1	G8ADM	IO91TO	2	133	G8LES	IO91LC	72
2=	M0DTS/P	IO94DE	1	112	G1LPS	IO94EQ	56
2=	G1LPS	IO94EQ	1	112	M0DTS/P	IO94DE	56

23cm

Pos	Call	Locator	QSOs	Points	Best DX	QTH	QRB
1	M0DTS/P	IO94DE	4	970	G7AVU	IO93OJ	107
2	G1LPS	IO94EQ	4	746	G7AVU	IO93OJ	153
3	G0EHV/P	IO94ET	3	396	M0DTS/P	IO94DE	70
4	G8BWC/P	IO83RO	1	100	G3UVR	IO83KH	50

13 cm

Pos	Call	Locator	QSOs	Points	Best DX	QTH	QRB
1	M0DTS/P	IO94DE	2	1260	G0EHV/P	IO94ET	70
2	G1LPS	IO94EQ	3	900	M0DTS/P	IO94DE	56
3	G0EHV/P	IO94ET	2	840	M0DTS/P	IO94DE	70
4	G8BWC/P	IO83RO	1	500	G3UVR	IO83KH	50

9 cm

Pos	Call	Locator	QSOs	Points	Best DX	QTH	QRB
1=	M0DTS/P	IO94DE	1	280	G1LPS	IO94EQ	56
1=	G1LPS	IO94EQ	1	280	M0DTS/P	IO94DE	56

6 cm

Pos	Call	Locator	QSOs	Points	Best DX	QTH	QRB
1=	M0DTS/P	IO94DE	1	560	G1LPS	IO94EQ	56
1=	G1LPS	IO94EQ	1	560	M0DTS/P	IO94DE	56

3 cm

Pos	Call	Locator	QSOs	Points	Best DX	QTH	QRB
1	M0DTS/P	IO94DE	2	755	G1LPS	IO94EQ	56
2	G1LPS	IO94EQ	1	655	M0DTS/P	IO94DE	56
3	G8BWC/P	IO83RO	1	250	G3UVR	IO83KH	50

Combined scores:

Pos	Call	Locator	70 cm	23 cm	13 cm	9 cm	6 cm	3 cm	Total
1	M0DTS/P	IO94DE	112	970	1260	280	560	755	3937
2	G1LPS	IO94EQ	112	746	900	280	560	655	3253
3	G0EHV/P	IO94ET		396	840				1236
4	G8BWC/P	IO83RO		100	500			250	850
5	G8ADM	IO91TO	133						133

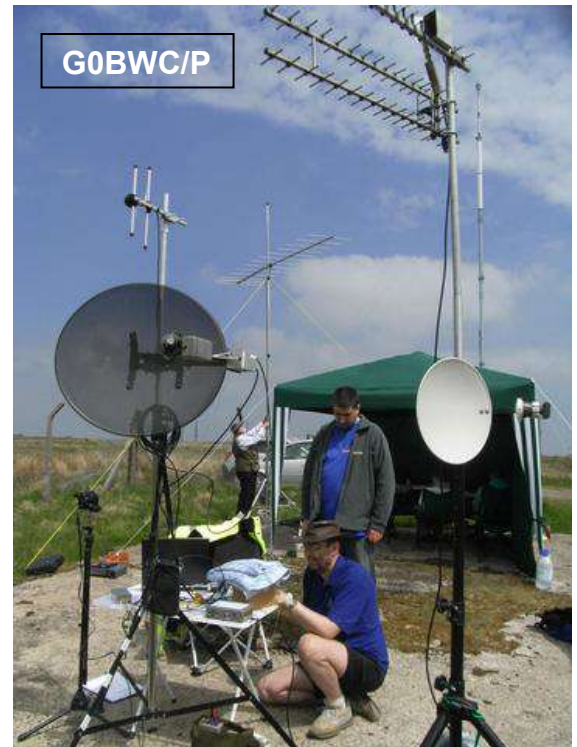

Congratulations to Rob M0DTS on winning and activating 6 Bands during the contest, aided by Terry G1LPS who was also active on all bands from 70cm to 3cm. This is the first year that I have seen contacts on 9cm. In addition to the stations who submitted entries, the following stations were also active: G8GTZ, G8LES, G3UVR, G4FVP/P, G7AVU and Brian G3KJX/P.

Brian, G3KJX/P reported that he had problems with equipment failures on the day. I know that there were few other stations, such as G4GUO, who were listening but found no activity. Thanks to all those who made the effort – especially the portable stations.

This was the first contest where entrants used DXspot.tv; it was fascinating to sit in Abu Dhabi and see what contacts were being arranged and made. A significant number of the contacts were made using digital modes.

The Bolton Wireless Club group were out portable competing in the PW 2m QRP event, but decided to take some ATV gear out with them as well. The picture shows Ross G6GVI kneeling, Dan M6NNX standing (and Alfred M3RNX in the background). The antennas are a mesh dish for 3cm TX, 70cm HB9CV for talkback, 12-ele ZL Special for the G8WY/P 2m QRP contest station, 18-ele Tonna for 13cm, Jaybeam 15-over-15 for 23cm, small white dish for 3cm RX, and in the background the 1000-ft Arqiva Winter Hill TV mast (not part of their station!).

Contest Information

I will be posting information about upcoming contests (and initial results) on the BATC Forum. Please take a look before the contest and post if you're going

to be active. The more people know that you are likely to be on-air, the more contacts you'll make!

IARU Region 1 International ATV Contest 14 and 15 September

Don't forget that the International Contest is on 14/15 September. The Dutch stations should also be using DXspot.tv to arrange activity; it might be worth dusting off the 70cm gear and pointing the beam their way.

Contact

I can be contacted through e-mail (contests@batc.org.uk), or through my BFPO address: Wg Cdr D G Crump, Defence Section, British Embassy Abu Dhabi, BFPO 5413, London.

Contest Calendar

1800 UTC 14 September 2013 to
1200 UTC 15 September 2013
International ATV Contest

1200 UTC 7 December 2013 to
1200 UTC 8 December 2013
BATC Repeater Contest

1200 UTC 22 March 2014 to
1200 UTC 23 March 2014
BATC Repeater Contest

1200 UTC 7 June 2014 to
1200 UTC 8 June 2014
BATC Summer Fun Contest

BATC DTX1 digital TV transmitter

MPEG-2 encoder and DVB-S modulator

- * Composite and S-Video input
- * 2 Audio channels
- * Single PCB design
- * Plug in option for 2nd video & audio channels

- * Tunes the 70cm and 23cm bands
Tuning range 150 Mhz - 2 Ghz
-5 dBm output level

- * Symbol rate: 1.0 to 8 MS/sec
- * Power 500 mA at 12 V d.c.
- * LCD front panel and keypad control
- * RS232 remote control port

Available from the BATC shop

- * PCB only for self mounting with display
(no keypad, 5 push buttons required)
= £399.00 plus shipping
- * Case, front panel and keypad
= £65.00 plus shipping
- * 2nd encoder channel
= £175.00 plus shipping

Specification may be subject to change without notice.



Introduction to BATC DTX1 – digital encoder / modulator

The BATC DTX1 digital encoder / modulator has been developed specifically for ATV use on 70 and 23cms. It is designed and manufactured in the UK for the BATC by Antennair in Manchester and although based on their consumer product, it has special ATV software and is only available through the BATC shop.

The unit comes as standard with a single channel MPEG2 encoder with composite / S video input and 2 audio channels. However, it has the option to plug in a daughter board which will give an additional video and 2 audio channels enabling the transmission of 2 channels within a single DVB-S multiplex. A possible future enhancement is the development of an MPEG-4 encoder daughter board but plans are not finalised yet.

The DVB-S modulator output is – 5dBm output between 350 and 1350 MHz so covers 70 and 23cms but actually works between 150MHz – 2 GHz at reduced output. The output can be used to drive an external PGA102 amplifier (see separate article) to produce up to 50 mW output which can then be used to drive a larger PA brick.

Note – although the DTX1 output is very clean (all spurious is below -60 dBm at +/- 50 MHz), the modulator design is very wide band and it is essential that band pass filtering is used on the output. We intend to publish suitable designs in future CQ-TV and there are a number of suppliers on the web - DG0VE sells suitable PCB filters at very reasonable cost.

An alternative to band switching on the output is to use a 70cms / 23cms duplexer designed for multi-band aerial / rig configurations – this will provide “automatic” band switching and provide some additional band pass filtering on the DTX1 output.

The DTX1 is totally configurable either through the front panel display or via the RS232 port and has 3 memories, which come ready configured for 437MHz, 1248 and 1275 MHz operation. The unit only requires 12 volts at less than 1 amp, and so is ideal for portable operation.

The DTX1 is available as an assembled and tested PCB with LCD but minus case parts and front pad keypad – wiring detail for the front panel switches is included. Case parts, including an Antennair front

panel, and the second channel daughter board, are available as separate items from the BATC shop.

The price we have negotiated for the PCB is significantly below the retail cost of the completed consumer unit and cheaper than any comparable unit on the market. Sales will initially be limited to one unit per BATC member, but if you require a second unit for a repeater or club, just email us and we will sort something out. In order to try and keep the price to a minimum, unlike most items in the BATC shop, we will be charging additional P&P – we are happy for people to collect units in person or to arrange bulk shipment of several units to the same address.

There is more detail on <http://www.dtx1.info> where you can download the user guide and other documentation.

Support for the DTX1 will be via a page on the BATC forum where you can ask questions and discuss the product and if you don't get the answer to your question there you can always email the DTX1 support team directly at support@dtx1.info



Unboxed Board

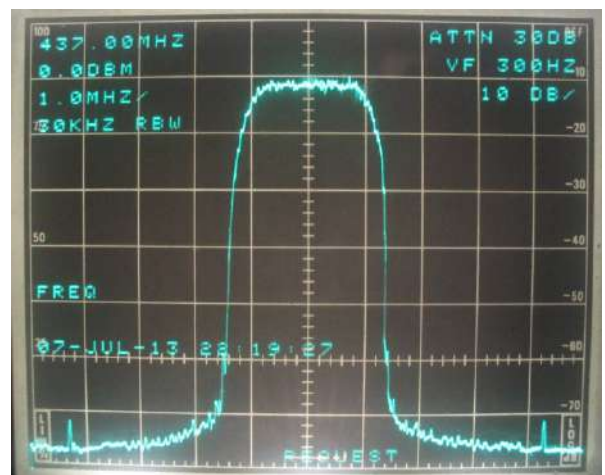

Output Spectrum

DTX1 – Reviewed by the first user.

By Mark Farnworth – G4WVU

In 2002 I noticed DVB-S was starting to make minor noises in ATV! DATV had started & I assumed that before long we would be consigning our trusty old WBFM kit to the junk boxes. I waited patiently for designs & information to appear, being neither a digital processing or computer expert I didn't read much beyond the fact that there was a lot of high speed processing for MPEG encoding & error correction going on! As time went by, some expensive German & Dutch kits became available, various projects appeared based around PC's encoding the MPEG element – most using specific cards & software etc. but still, little or no kit surfaced that the common ATVers (such as myself) might be capable or interested in building or buying.

Almost a decade on I decided to look at other methods to generate a DVB-S signal & after some research concluded that DVB-T modulators were becoming more widely available & were likely modifiable to DVB-S as they're essentially very similar. By this time a number of devices were available aimed at DVB - T distribution for hotels, corporate & rich domestic clients etc. I approached a number of vendors to see if any would be interested in making a DVB-S version – most vendors seemed vague on anything technical & it proved hard to actually contact the original manufacturers.

However a Manchester based company (Antennair) bucked the trend & seemed genuinely interested in the proposition of a DVB-S version of their unit . Within some weeks they shipped me a pre-

production DVB-S version of their DVB-T unit with beta firmware to try out & feedback comment on. The unit is neatly housed in a small extruded aluminium box with buttons & LCD on the front & all connectors on the rear. I'm not a fan of the buttons (membrane type) but they work. I eagerly plugged it in to see how it might fair in comparison with some NDS broadcast equipment. (*editor note: This was co-incidentally around the same time as the BATC approached them!*)

Frequency coverage was wide: 140-2000 MHz but the modulator chip was only specified above 400MHz (still pretty wide!). I started tests on 1250mhz, Symbol Rate 4000 & FEC ½ & sure enough the STB (Fortec Star FS4000 II) I was using for tests acquired lock. I applied video & it appeared – magic I thought!

However I had been asked to look out for bugs & there was known issues with Transport Stream mux. overruns that were being looked into. I quickly noticed quite bad macro blocking & a few other issues when changing rates etc. The RF level was also much lower at 1250 than 437 MHz (about 8dB less). I reported all my findings back to (Antennair) & within days a new firmware version arrived by email to load in on the rear RJ11 port. This sorted all the macro-blocking issues & nice video performance was apparent immediately. The delay at higher bit rates (> 6Mb/s) was noticeably very low.

The drop-off in RF level persisted however, so I decided to investigate the RF output side of things. The unit is

designed as a Band 4/5 modulator & is equipped with an F socket on the rear of the circuit board. The RF output essentially comes straight from the modulator chip (an Analogue devices ADL5375 which is rated 400 – 6000mhz @ max +9dBm) via a pad, so I suspected board layout / connector issues to be the cause (bearing in mind the unit was not designed to operate above ~800Mhz originally). I soldered a small (RG174) coax at a junction where the original 75ohm pad was situated & took the signal straight to a spectrum analyser for measurements (bypassing the subsequent board track & F connector). The results were a revelation at the higher frequencies: RF output was -6dBm at 437MHz & -6.5dBm at 1250 Mhz (cable loss corrected), in fact the output level was essentially flat from 400 - 2000Mhz dropping a little towards the high end. (*Editor Note – the units supplied by BATC have a modified PCB*)

-6dBm is a good drive level for a single MMIC to obtain sufficient drive for a brick type PA. and I have the unit running to a Minicircuits PGA103 MMIC - giving +17dBm (50mW) on 437mhz & + 11dBm on 1250mhz. On 437mhz this is enough to reliably access GB3TN's DVB-S input at 2 miles via an 8dB "bow tie" NLOS. Close in spectrum purity is excellent with shoulders at typically => -60dB down. Overall the unit, which is now being supplied by the BATC shop, is an excellent plug and play unit for the average amateur to get going on 70cms and 23cms DATV at a cost which is not much more than a dual band mobile FM rig!

Standardising PID's for DATV

By Noel Matthews, G8GTZ

The value of the PID (Packet Identifiers) used in our DATV transmissions has become an issue as most receivers do not seem to be able automatically lock to any value. This means that receivers refuse to receive otherwise good transmissions – this is can cause particular problems at repeaters which receive transmissions from a number of stations but the receiver has to be preset by the keeper when visiting the site.

I have been involved with at least 3 cases recently where much time and effort was spent trying to sort out potential RF issues

and all it required was a change of PID at the transmitting station.

Also, if we do not all work to one standard, it will prevent DX stations from accessing remote repeaters during lift conditions.

It has therefore been suggested that we should all standardise on the values preset in Digilite (the DTX1 will have the same values pre-programmed in to the memories) and that repeater receivers should all be set to receive these values:

Video PID= 0X100 = 256	Values
Audio PID= 0X101 = 257	< in
PMTPID = 0XFFF = 4095	Decimal

To change the values you will need to delete any memory / channel settings stored in the receiver at repeater site and then get a station with these PID settings to transmit and be accepted as the default.

When you have confirmed our repeater uses those values it would be useful if you can let us all know by posting on the BATC forum.

For more details see the repeater technical section on the BATC forum: <http://www.batc.org.uk/forum/viewtopic.php?f=82&t=3201>

PGA103+ broad band 50mW amplifier.

Mark (G4WVU) in his DTX1 review mentions the PGA103 amplifier that he used as a driver to give 50 mW output.

As well as the pre-built unit which is available from Mini-Kits in Australia, Sam Jewell (G4DDK) also produces a kit for the amplifier, which is described in the following article.

As Sam explains in the article, the PGA103 can also be used as a very high performance pre-amplifier on 70 and

23cms but does require surface mount soldering techniques.

However, as the unit is so versatile and has many ATV applications, we have decided to make it the focus of the SMD workshop which we will be running at CAT13 at Finningley at the end of October.

At CAT13 you will have chance to buy, build and test your own unit.

We will have stock of Sam's kits available for purchase at £12.

Kevin G3AAF will be running a hands on SMD class and there will be RF test equipment up to 10 GHz to enable you to test your unit as both a receive pre amplifier and a transmit driver. – ed.

By Sam Jewell, G4DDK and Kent Britain, WA5VJB

Introduction

This paper describes a low noise, high dynamic range VHF/UHF preamp that uses the Minicircuits (MCL) PGA103+ P-HEMT MMIC device.

The PGA Amp achieves 0.5dB noise figure from 50MHz to 144MHz and

0.55dB at 432MHz. At 1296MHz the noise figure is 0.85dB.

However the real PGA Amp advantage is its incredible dynamic range. The Input third order intercept (IIP3) is better than +10dBm at 144 and 432MHz and over +20dBm at 1296MHz! It is possible to

optimise these figures for particular frequency ranges.

The design, as described, is optimised for the lower VHF and 432MHz bands. The PGA Amp requires just a single 5V supply at 84mA.

It is a broadband amplifier and this means that if it is going to be connected directly to an antenna it may be necessary to use a low loss input filter to reject the strongest out of band signals whilst

minimising additional losses that will add directly to the preamplifier noise figure. A suitable filter is described, for use at 144MHz, that provides more than 20dB attenuation across the whole FM band,

with over 50dB at 98.5MHz. A suitable 432MHz filter will be described in a future article. The circuit diagram could not be simpler. The PCB is designed to accept 0603 size SMD parts

Circuit schematic and assembly

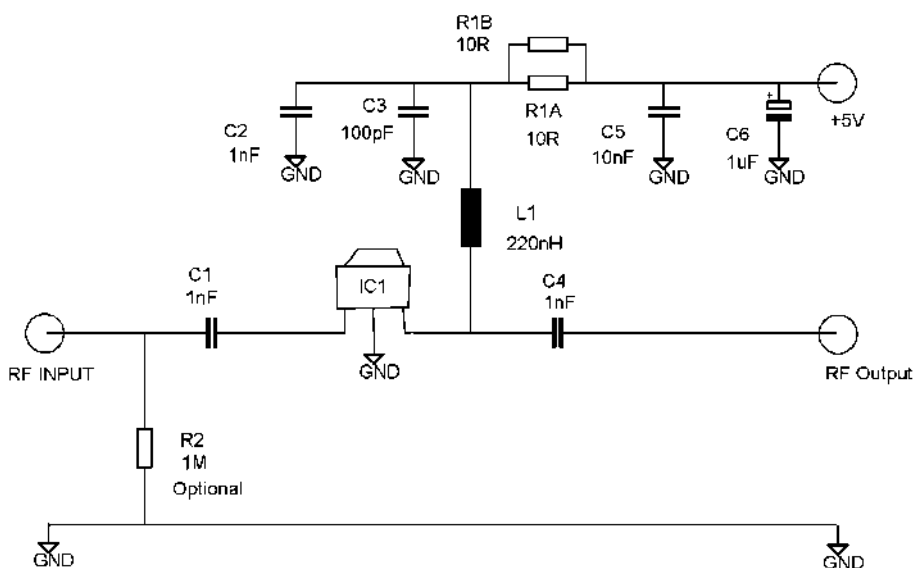

Figure 1 shows the circuit schematic of the basic PGA103+ amplifier.

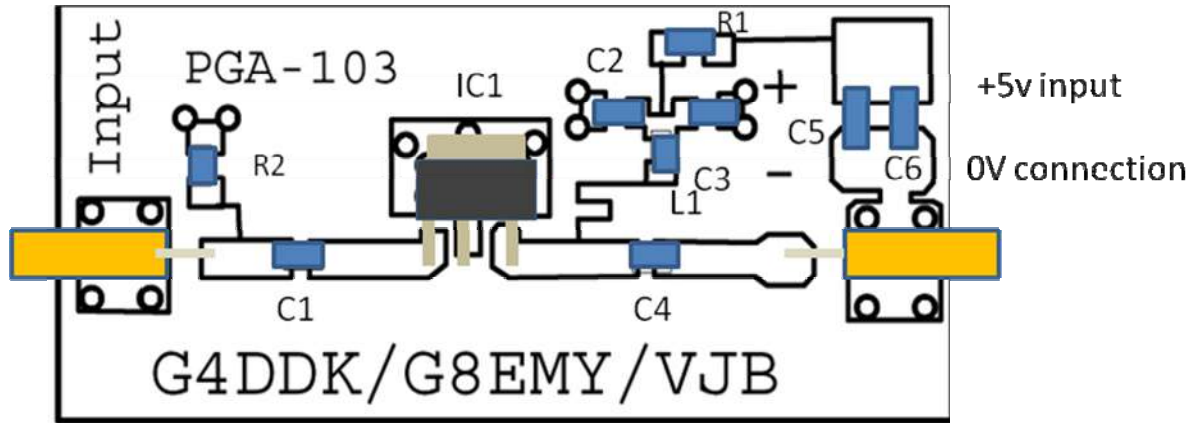

Figure 2 shows the component placement for the PGA AMP. C5 and C6 are fitted across the input power pads. R2 is an optional 1MΩ 0603 size SMD part that can be used as a static leak where static build up may be a problem. IC1 should be

mounted with its leads well down the input and output tracks to prevent them shorting to the ground pad. The ground lead can be left unsoldered but the tab MUST be soldered to the ground pad

once you are happy that the input and output leads are not shorting to ground.

Component values below:

Component	Value	Package
R1	50 Ohm. 2 x 100 ohm in parallel	SMD0603
C1, C2, C4	1000 pF	SMD0603
C3	100 pF	SMD0603
C5	10 nF	SMD0603 / 0805
C6	1 uF	Case A size
L1	220 nH	SMD0603
IC1	PGA103 +	SOT89
R2	1 M ohm	SMD0603 optional Not supplied

Box

The PCB should be populated before attempting to fit the PCB into the box. The cable termination PGA AMP PCB fits perfectly into one of the common little tin plate boxes. This is the 20mm x 20mm x 37mm size filter box (FG1) made by Schubert GMBH These boxes are

available from G3NYK in the UK and from Eisch-Kafka Electronic in Germany.

Short lengths of UT141 coaxial cable with SMA connectors (either male or female) are used for the input and output RF connections. 3.5mm holes need to be

drilled exactly in the centre of the box ends as shown to accept the coaxial cable pigtails.

The coaxial cable fits through the holes and terminates on the PCB input and output pads as shown in photo 1.

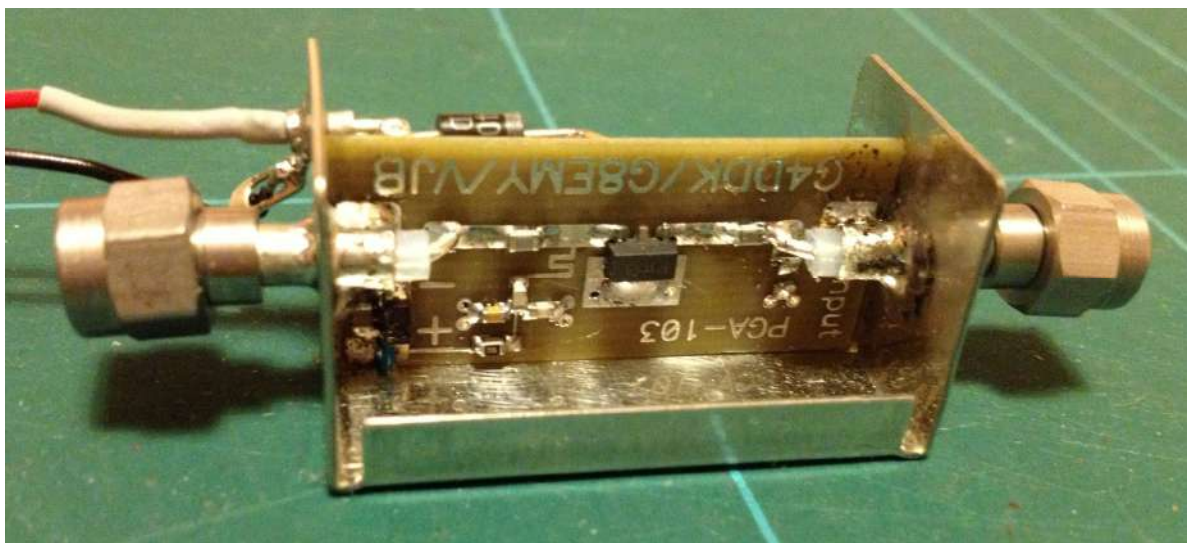

Photo 1 The PCB is soldered vertically into the box with the board input and output pads slightly offset to the 3.5mm diameter holes.

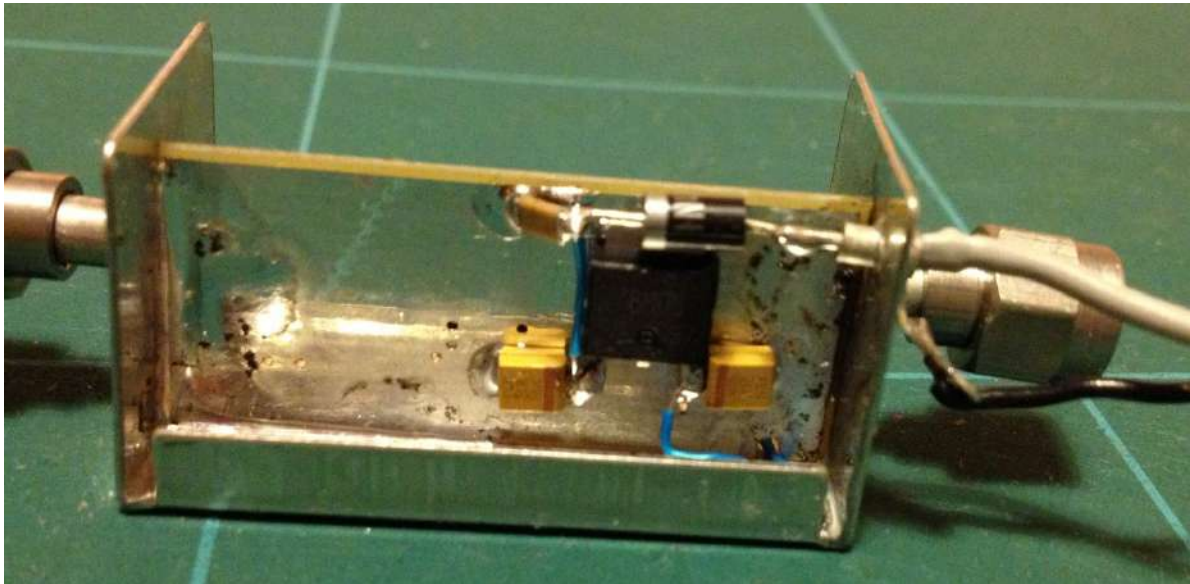

Photo 2 shows the extra 5V regulator added onto the rear of the PGA Amp PCB

I chose to solder a 78M05 5V/500mA SMD regulator to the ground-plane side of the PCB with 10 μ F/ 20V working tantalum capacitors for decoupling.

This ensures that whatever the input supply voltage variation no more than +5V appears at the PGA AMP.

I used a Tusonix 1500pF solder-in feed-through capacitor to bring the supply into the box and then a 1N4001 as a series 'idiot diode' to prevent reverse polarity disasters.

Results

Table 2 shows the results obtained from a boxed PGA AMP. The usual caveats apply, i.e. systematic uncertainties in the

measurements, particularly of the noise figures, test equipment calibration, quoting noise figures to hundredths of a

dB! etc. These numbers were obtained using the newer FR4 PCB.

Frequency (MHz)	Noise figure (dB)	Insertion gain (dB)	Input IP3 (dBm)	Input return loss (dB)	Output return loss (dB)	Psat Output (dBm)
30	0.5	26.2				
50	0.5	26.2		3.8		
70	0.5	25.9		5.2		22.1
144	0.47	25.1	+11.8	8.7	22	22.5
432	0.53	21.0	+10.5	10.6		
1296	0.8	14.1	+20.5	14.7	15.4	24.5

Table 2 Measured performance of one sample of the PGA103+ amplifier mounted in the recommended tin plate box.

Summary

Whilst an IIP3 of +11.8dBm at 144MHz is impressive, an IIP3 of +10.5dBm at 432MHz is also pretty good for a device delivering over 20dB of gain and around 0.5dB noise figure.

At 1296MHz the IIP3 is also extremely good at over +20dBm. However, this figure could be improved significantly by

careful selection of the device operating point. Potentially, it could be as high as +26 to +30dBm.

These are the numbers achieved at 1.9GHz in the original cellular radio base station mast head preamplifier application of this device.

One of the advantages of this small high performance amplifier is that it is so small that it can be fitted inside many existing transceivers as an alternative receiver front end or even a replacement driver stage, possibly giving a large increase in receiver performance or restoring transmitter drive to a PA.

CAT13 Finningley – October 26th and 27th 2013

The Finningley Amateur Radio Society has an enviable club house that is often used by other organisations such as the UK Microwave Group and now we will be there for our 2013 convention CAT13. The club premises are situated just outside Sandtoft, after the village, and before the South Yorkshire Transport Museum. Access for the disabled is not a problem. The club is located on Belton Road, just past the village of Sandtoft, and before the South Yorkshire Transport Museum in North Lincolnshire. The nearest postcode if you're using sat-nav to find us is: DN8 5SX.



CAT13, Convention Programme.

Preparations are well underway for Convention for Amateur Television 2013 (CAT13) over the weekend of 26th and 27th of October at the Finningley Amateur Radio Club facilities near Robin Hood airport in Yorkshire.

CAT13 will start at 10:00am on Saturday and finish around 4pm on Sunday and the program of talks is shaping up to include a number of interesting topics:

Finningley Club website: <http://www.g0ghk.co.uk/club-information/about-fars>

- 10 GHz ATV equipment and operation
- Ku band LNB developments and the use of PLL LNBs on 10 GHz
- How to get going on 70cms DATV and experiences to date
- HAMTV on ISS – introduction and how to receive it in your back garden
- High Altitude Ballooning – Introduction and possible demo with video downlink
- Digital update – including the latest from the Digilite and DATV express teams
- Narrow band modes below 432 MHz – presentation and discussion
- Talk and demo of a very exciting new DATV product which will be in the BATC shop shortly

As well as the talks program, there will be plenty of time for meeting other ATVers and visit the other activities on site including:

- SMD soldering workshop where you can buy, build and test equipment
- Demonstration area
- Comprehensive RF test and measurement equipment up to 10 GHz
- Selected RF and video suppliers
- Members bring and buy area
- Antennae test range (Sunday only and weather permitting)

Kevin, G3AAF, will be running an SMD workshop throughout the weekend. It is planned to have G4DDK kits available for sale and you will be able to buy, build and test the unit on site – it will be a great way

to get used to soldering SMD but also know that the pre-amp you built works!

We will also have some SUP2400 70cms rx upconverters which you can buy,

modify and test. Let us know if you have any other ideas for SMD kits which we could have available on the day or feel free to bring along any project that you need help to get finished and tested!

Possible member demos will include MK808 video encoding by Rob (M0DTS) and nanowave ATV – there's plenty of room, both inside and outside, so bring along any interesting demos that you are working on.

We are hoping to have an antennae test range up to 10 GHz, but this will depend on the weather on the day – so bring along that homemade 13cms yagi or 70cms 19 ele Tonna and we will tell you how good or bad it really is!

Admission to CAT13 is £10 per day (payable on the door) which will include free tea and coffee all day and lunch provided by Finningley Radio Club.

Registration for the event on the FARS site will be open from mid September

<http://www.g0ghk.co.uk/calendar/viewevent/90-batc-convention>

For those travelling from distant parts, there are several hotels close by:

The Reindeer at Sandtoft is 5 minutes walk away and has 7 rooms available – the BATC has negotiated a special rate of £65 per night.

Please book directly with Jan at the Reindeer on 01724 710 774 or parkerjan27@hotmail.co.uk but quote BATC to get the special rate.

There is also the Red Lion in Epworth and the Travel Lodge at Junction 18 on the M180 currently (mid Sept) has rooms for £26 per night.

We will be arranging a dinner on the Saturday night at the Reindeer Inn in Sandtoft:

<http://www.thereindeerinn.co.uk>

Once again, please book directly with Jan at the Reindeer on 01724 710774 or parkerjan27@hotmail.co.uk who has arranged a special menu including vegetarian options.

We are still looking for talks, demonstrations and help with the organisation of the event so get in touch if you can help. More details to follow, but put the date in your diary now and let's make this an even bigger success than the Convention in 2012.

Admission: £10 per day (payable on the door)

Registration at: <http://www.g0ghk.co.uk/calendar/viewevent/90-batc-convention>

Reindeer Hotel, Sandtoft

Tel: 01724 710 774,

Email: parkerjan27@hotmail.co.uk

Red Lion Hotel, Epworth.

Tel: 01427 872 208,

Email: info@redlionepworth.co.uk

Reindeer Dinner booking:

Tel: 01724 710 774,

Email: parkerjan27@hotmail.co.uk

BATC Presentation

Phil Crump (M0DNY) received his BATC grant at the Newbury Rally in June for development of the

DXSpot.tv website. Left to right, Phil, Noel Matthews, Dave Mann and Brian Summers.



www.DXSpot.tv a new web facility from the BATC

The BATC is pleased to support an exciting new project called ATV Dx Spot, a next generation web based facility open to all ATVers worldwide to encourage and enable DX ATV working.

www.dxspot.tv is a dx cluster chat room facility designed specifically for the worldwide ATV community with an easy to use DX cluster spotting interface for ATV contacts on all bands between 70cms and 3cms. Designed for mobile and PC use, Dxspot.tv includes an instant messaging facility with other ATV operators via a dedicated IRC channel and a real time interactive map showing

active ATV stations and repeaters and reported ATV dx spots.

ATV DX cluster spotting for 70cms – 3cms
ATV and DATV

Interactive map showing all active ATVers worldwide

Clickable map to show QRA and active station search

Dedicated instant messaging IRC channel for ATV DX working

Open source environment with github for full development co-operation

When you first visit the site you will see the world map. Once you have registered with your callsign and location, when you login you will see the picture below with your location at the centre. The screen is divided into 3 main areas:

The interactive map

The map displays stations that are active and licensed TV repeaters with coloured icons to display their status. Clicking on a icon will display information about the station.



Global Spot Log

7 September 20:43:13	PE1HIS->PI6TV 5cm 0780 MHz
5 September 18:17:29	MO1KB->PI6ZTM 23cm P1 picture may be PI6ZTM
4 September 13:21:38	G3PYB->G3PYB 70cm looking sooth for 70cm datv
1 September 21:24:00	G8GTZ->GB3MCB 70cm S1

New Spot

70cm Analog TV

Remote Callsign:

Locator:

Frequency / Comments:

- = Stations who are logged in and are "radio active"
- = Stations who are logged in but have set their status to "just monitoring"
- = Stations that have been reported in a DX spot but are not logged in
- = Operational TV repeater
- = Licensed but non operational TV repeater

The map will also show any ATV or DATV DX paths that have been reported using DXcluster - clicking on the line allows you to see the 2 stations in the QSO, the distance and the band reported. These are shown by a coloured line depending on the band used – spots of narrow band beacons are also possible to be reported via dxspot.tv and are shown as a dotted line in the appropriate band colour.

- = 70cms
- = 23cms
- = 13cms and above
- = 70cms NB beacon

Global spot log

The area below the map shows a global spot log for all dxcluster spots which are identified with the ATV or DATV description.

IRC chat window

To the right hand side of the screen is the dxspottv chat room window, which when you log will show a list of all other active ATV stations and chat messages between the stations.

Mobile operation

Dxspot.tv was specifically developed using readily available web components,

as such it is possible run separate applications such as a mobile or web IRC client when out portable on a restricted bandwidth 2G connection.

Simply log in to #dxspottv on the 'chat.freenode.net' with your mobile using a dedicated IRC client and you will appear in the active stations list and able to message any stations logged in via www.dxspot.tv

A future planned enhancement will give an option whereby just logging in to #dxspottv will automatically register you on the interactive map.

Help and feedback

A page has been set up on the BATC forum <http://www.batc.org.uk/forum> where users can give feedback and help will be available from the ATV community.

Credits and Github

www.dxspot.tv has been developed by Phil Crump, M0DNY, from a specification originally generated by Noel Matthews, G8GTZ. The program has been developed using the github open development environment and new members and contributors are welcome to sign up and help us develop this resource for the ATV community.

BATC Telephone Number: 01400 414 243

Treasurers Report for 2012

By Brian Summers. Hon. Treasurer

The club has had a busy year with the BGM and other exceptional outgoings leading to a modest loss of **£567.59** compared with the previous years surplus of £1926.05. The club remains in a financially strong position.

The BATC shop and publications

The BATC shop continues to supply the needs of members and generated a significant income of £2002, after allowing for PayPal commission. The sale of DVDs and CQ-TV back issues raised a useful sum of £152.

BATC bank accounts

Over the years the BATC has opened accounts as needed and now some of these are redundant and have been closed. Nationwide, Halifax and Santander have gone and HBOS will go soon. We bank with HSBC and our

reserves are with the Teachers Building Society.

Payments methods

The BATC PayPal payment system continues to work well. This payment system is available for most of the world. You do not need a PayPal account to use it, and it works with credit & debit cards. If you are in the UK a cheque or postal order is very acceptable and avoids the commission charges levied by PayPal. Payment can also be made by bank transfer.

We are not able to accept direct card payments as this has proved not to be cost effective, but most cards can be used through the PayPal system.

In extreme cases payment can be made by Sterling, Euros, or US\$ notes by post at the senders risk. If you have problems please contact us and we will try to find a solution.

Notes to the accounts

1. Members services old stock of - **£299.54** has been written off.
2. The PayPal commission of - **£533.74** appears in the income section as it is deducted at source so we never had it.
3. The donations figure of £2000 is to BATC Ltd.
4. The office expenses figure includes £748.80 for the postal ballot.
5. The committee expenses includes accommodation at streaming events
6. Equipment was purchased to the value of £2334.38; this included editorial software and upgrades, a new camera, tripod and radio microphone. The latter items are for use at the BGM and streaming events.

BATC INCOME & EXPENDITURE ACCOUNT YEAR ENDING 31 DECEMBER 2012

Income account	2011	2012	Expend account	2011	2012
Subscriptions	£6,645.75	£6,150.12	CQ-TV Printing	£3,062.55	£3,245.00
Postage, airmail	£115.50	£0.00	CQ-TV Postage	£1,654.12	£1,606.56
BATC Shop surplus	£1,631.39	£2,369.54	CQ-TV Production	£450.00	£450.37
Members Serv. Surplus	-£299.54	£0.00	Office expenses	£186.36	£812.85
Publications surplus	£70.47	£152.79	Committee expenses	£74.15	£637.90
Donations received	£90.00	£158.20	RSGB affiliation fee	£51.00	£51.00
Interest received	£290.96	£475.22	Benefits & Projects	£0.00	£393.70
Miscellaneous Items	£77.00	£103.40	Donations & web services	£500.00	£2,000.00
Convention & BGM	£0.00	£297.50	Convention & BGM	£0.00	£523.24
Less PayPal commission	£0.00	-£533.74	Bank & PayPal fees	£717.30	£20.00
	<u>£8,621.53</u>	<u>£9,173.03</u>		<u>£6,695.48</u>	<u>£9,740.62</u>

BATC BALANCE SHEET AT 31 DECEMBER 2012

Fixed Assets	2011	2012
Equipment purchases	£0.00	£2,334.36
Less depreciation	£0.00	-£2,334.36
Current Assets		
Stock, BATC Shop & BATC Publications	£530.00	£1,024.73
Nationwide building society	£249.08	£0.00
Halifax building society	£24,579.67	£0.00
Teachers building society	£21,916.36	£44,255.06
HBOS account	£12,814.68	£222.24
Santander account	£1,470.85	£0.00
HSBC account	£1,887.34	£14,702.00
PayPal account	£1,962.45	£2,827.69
Less Current liabilities		
Subscriptions received in advance	-£6,848.04	-£5,036.92
	<u>£58,562.39</u>	<u>£57,994.80</u>
Represented by Accumulated fund		
Balance brought forward	£56,636.34	£58,562.39
Surplus	£1,926.05	-£567.59
Balance carried forward	<u>£58,562.39</u>	<u>£57,994.80</u>

I have examined the books and records of the British Amateur Television Club and confirm that the balance sheet and the income and expenditure account are in accordance with those books and records.

EXAMINED
ACC
P. Bicknell
P.A. BICKNELL

B. Summers
B. SUMMERS
HON TREASURER

16 June 2013

16 June 2013

50 years of home video recording.

By Peter Wright, G8GYS

50 years ago last June, humans developed the first home video recorder. One of these was produced by Philips and used reels of tape and valves (tubes). Peter Wright purchased one second hand and had a great time changing the electronics to solid state and adding colour operation. This was a remarkably successful project for the young Peter working in his spare time at home. Here's his account of how he did it:

Philips EL3400 VTR



The Philips EL3400 was designed in the early 1960s, used valves, and was monochrome only. It was thus old when I bought it second-hand in the late 1970's from an ad in Exchange & Mart.

It was an early, pre-cassette attempt at a semi-domestic video recorder. It used helical scan, and 1" wide tape, with "omega wrap". To briefly describe the principles of this, the tape from the feed spool is wrapped once around a stationary circular drum of around 170mm diameter, with the tape wrapping in the shape of the Greek letter Omega. It leaves the drum one tape-width lower than it arrived, and then passes to the take-up spool. There is a spinning disk within the drum which has a record/playback head on the periphery, which protrudes through a horizontal slot running round the centre of the drum, such that it just contacts the tape through the slot. The tape is simultaneously transported (at 7.5 ips) from the feed spool to the take-up spool by means of a capstan and pinch-roller, similar to an audio tape recorder. This means the head, when rotating, effectively scans the tape in a series of consecutive diagonal stripes. The head records the video signal, which is frequency modulated on to a carrier to reduce the frequency dynamic range, as it would be difficult to record base-band video in this way. The signals from the head pass via a rotary transformer to the outside world. The head drum speed is synchronised to the TV field rate such that one diagonal recorded "stripe" contains a complete TV field. A pair of fixed heads record a linear control track and the audio signal respectively. The control track is effectively field sync pulses and is used in

playback to lock the servos, adjusting the speed of the tape transport and rotating head drum such that the recorded tracks are replayed accurately. A full tape-width linear erase head enables tape re-use.

A novel feature of this machine is that the head can be removed easily for transportation of the machine! It just slides out of a slot in the disk, where it is held only by centrifugal force when spinning. The tape penetration adjustment is carried out on the receptacle that the head slides into.

Having got the machine, the intention was to make it work reliably, and also for it to operate in colour. It worked as received, but was very unreliable, especially the servos. Also the video quality and sync pulse shape on the output was poor. The servo used valves, and there was a pot inside to set servo lock range. After running for a little while, the valves drifted, and the servos would go wildly out of lock, needing the pot to be constantly tweaked!

The servos were thus the first thing to go. I re-designed them using ICs and transistors, utilising the "phase comparator 2" part of the CD4046 C-MOS PLL chip to provide an edge-triggered adjustment-free servo system. This worked a treat after a bit of playing with the critical damping to make it lock-up smoothly.

Next was a new erase oscillator, using a push-pull pair of transistors driving a ferrite transformer at around 60KHz in the audio system.

Then it was the turn of the video amplifier FM system. This was replaced with solid state electronics, but the sync pulse shape was poor and also suffered from a field disturbance. A side effect of the omega wrap is that the rotating head leaves the tape momentarily at the bottom of the omega. This is timed by the servos to happen in the vertical blanking interval so there is no picture disruption, but this means the horizontal sync pulses disappear momentarily for a few lines, and there can be a glitch there too. I built a sync regenerator for the machine to fix this. It used a Ferranti ZNA134J single-chip sync-generator chip, I think the first of it's kind, and a very new device at the time. I genlocked it to the video output using an agile phase-controlled LC master oscillator and divider to feed clock signals to the chip, rather than using the normal crystal. This was so that it could follow the mechanical jitter of the syncs from the machine. I built a processing amplifier which clamped and re-blanked the VTR video output using the mixed

blanking from the chip, and current added the chip mixed sync on to it. The result was a much improved, stable, continuous sync.

The final stage was colour. I decided to use "colour under", which was the system used by the emerging VCRs of the time. This works by separating the chrominance and luminance components of the PAL video input with filters, and feeding the filtered luminance to the FM modulator for recording as normal. The chrominance signal is then frequency shifted down to below the lowest frequency components of the FM signal being recorded, and is added to that signal before it goes through the rotary transformer to the head to be recorded on tape. The FM luminance signal is effectively a carrier, which acts as a tape bias for recording the AM balanced chrominance, overcoming the tape non-linear transfer characteristic.

In order to frequency shift the chrominance from 4.43MHz to a low enough frequency to go under the FM luminance, I used a carrier frequency extracted from within the sync generator clock divider chain, taken into a mixer chip together with the chrominance, and mixing it down to 640.625KHz, a convenient multiple of line frequency. The FM luminance signal extended from about 1.5MHz to about 4MHz so this fitted in nicely. On playback, the chrominance was mixed back up to 4.43MHz using the same carrier signal from the divider chain. The chrominance played back from the tape suffers from the same mechanical jitter as the luminance, which would make it unusable in a decoder. However, the carrier frequency from the divider chain that it was mixed with is part of the sync regenerator and thus phase locked to the jittering sync coming from the machine, so has the same jitter itself. Thus the jitter effectively cancels in the mixing process, giving stable PAL chrominance. This was then current added to the luminance output from the sync regenerator, giving a working PAL output. An analogue delay line was added to the luminance path in the sync regenerator to restore correct Y-C timing, and an "edge enhancer" to sharpen the luminance.

This system, believe it or not, worked amazingly well and gave a result not much different to a VHS recorder. It was used on 70cm many times! (You can see some recordings made by this machine on www.batc.tv Select: Film Archive, Select: BATC Classic, Select: 1-Andover and 2-Andover. Ed)

A Beginner's Guide to Field Programmable Gate Arrays (FPGAs). Part 1

By Charles Brain G4GUO

Introduction

This is the first in a short series of articles on how to get started using FPGAs. This first article I hope will appeal to everyone even those of you that have no intention of becoming FPGA programmers but are merely interested in what these devices can do and in what sort of situation they can be used.

History

First a little bit of history, the forerunner of today's FPGA was the PLA or Programmable Logic Array these first became available in the 1970s and were mainly used as glue logic. The first true FPGA as we would recognise it today came to market in around 1986.

Things have moved a long way since then. Nowadays FPGAs are used in everything from simple

glue logic to high volume trading on financial markets. They are the closest most hobbyists will ever get to designing their own chips. They can be configured in the field over and over.

Closer to home FPGAs are used in the following products, TAPR HPSDR (SDR), QS1R (SDR), PERSEUS (SDR), FLEX 6000 series (SDR), Digilite-ZL (DATV), DATV-Express (DATV), SR Systems Minimod (DATV), AOR ARD 9800 (Digital voice) to name a few. My first encounter with an Amateur FPGA based device was a 9600 baud packet radio controller by IV3NWV introduced in 1997.

Why use an FPGA why not use a CPU?

For most applications a CPU is probably a better choice but if you need to manipulate large quantities of high speed data in real time like in signal processing or HD video then an FPGA is a better choice. Most often FPGAs are used in conjunction with CPUs as their functions compliment one another. The FPGA could be regarded as a co-processor to the CPU when used that way. The power of an FPGA is that it can run many modules all at once, a traditional CPU can only do them one at a time.

So what is an FPGA?

Put simply they are a group of cells. The cells are a mixture of logic units, memory units, IO units and some configuration memory. These cells are then wired together using an interconnect fabric. The details of how the logic units are constructed vary between manufacturers but are by and large hidden from the designer. Modern FPGAs also have specialist cells such as high speed hardware multipliers (for DSP) and phase locked loops (PLLs). They also have dedicated clock distribution buses that insure low clock latency throughout the chip. The chips do not store their configuration so are usually used in conjunction with either serial flash memory or a micro-controller. At power up they have to reload their configuration from the memory device.

To give an example the FPGA used in DATV-Express EP2C8T144C8N has 2 PLLs, 36 hardware multipliers, 85 IO pins, 165 kbits of memory and 8,256 logic elements. The FPGA comes in a 144 pin package. The logic units can operate at up to 400 MHz but unlike a CPU they can operate independently and execute in parallel. When powered up the configuration for the board is downloaded from a host computer using a USB2 connection. In small quantities the chip costs \$19.20.

Vendors

The two main vendors of FPGAs are Xilinx and Altera, Xilinx being the market leader, others include Lattice and Actel who tend to do smaller or more specialist products. I only have experience of Altera's range of FPGAs.

Development Tools

Configuring these chips by hand would be very difficult and time consuming. Thankfully the manufacturers provide free development software. The chip used in DATV-Express is manufactured by the

Altera Corporation and their design tool is called Quartus II. This tool can be downloaded from their website and will run either on Windows or Linux. The equivalent tool from Xilinx is called ISE Design Suite. An example of the Quartus II GUI and a small part of the DATV-Express design is shown below

Altera also have a softcore CPU called NIOS which allows you to download a tailored CPU core to the FPGA if your design requires it. You can download only those parts of the CPU you require so saving on space. I will not be covering NIOS development in this series.

Quartus II, screen shot on next page, allows design entry in two main ways, either schematic capture or via HDL (Hardware Description Language). You can also mix the two in the same design. The HDL used on DATV-Express is called [Verilog](#). In Europe a language called VHDL is more common, if you do a college course in FPGA design VHDL is almost certainly the language you will be taught. I chose Verilog because a number of Amateur projects already use it and it is very much like the C programming language which I am familiar with. VHDL is a more formal language and has sometimes been likened to programming in Ada. Quartus II can accept input in either of these languages or their variants as well as using schematic entry, Quartus II has examples in both languages in it's documentation.

Verilog was originally written for logic simulation and only a small subset of it is actually used for logic synthesis. This can be confusing to the newcomer. A professional engineer when designing an FPGA would also create a 'testbench' using the simulation features of the language to verify his/her design. We will concentrate only on the logic synthesis not the simulation. For those that are interested in simulation Quartus II includes a program called ModelSim-Starter Edition which can do the simulation.

Internet links:

http://cva.stanford.edu/people/davidbbs/classes/ee108a/winter0607%20labs/ee108a_nham_intro_to_verilog.pdf ' An introduction to Verilog
<http://www.altera.com/> ' an FPGA Development Kit
<http://www.terasic.com.tw/en/> ' FPGA Kits
<http://www.altera.co.uk/literature/br/br-soc-fpga.pdf> ' System on a chip
<http://www.terasic.com.tw/cgi-bin/page/archive.pl?Language=English&CategoryNo=167&No=816> ' a board for the above

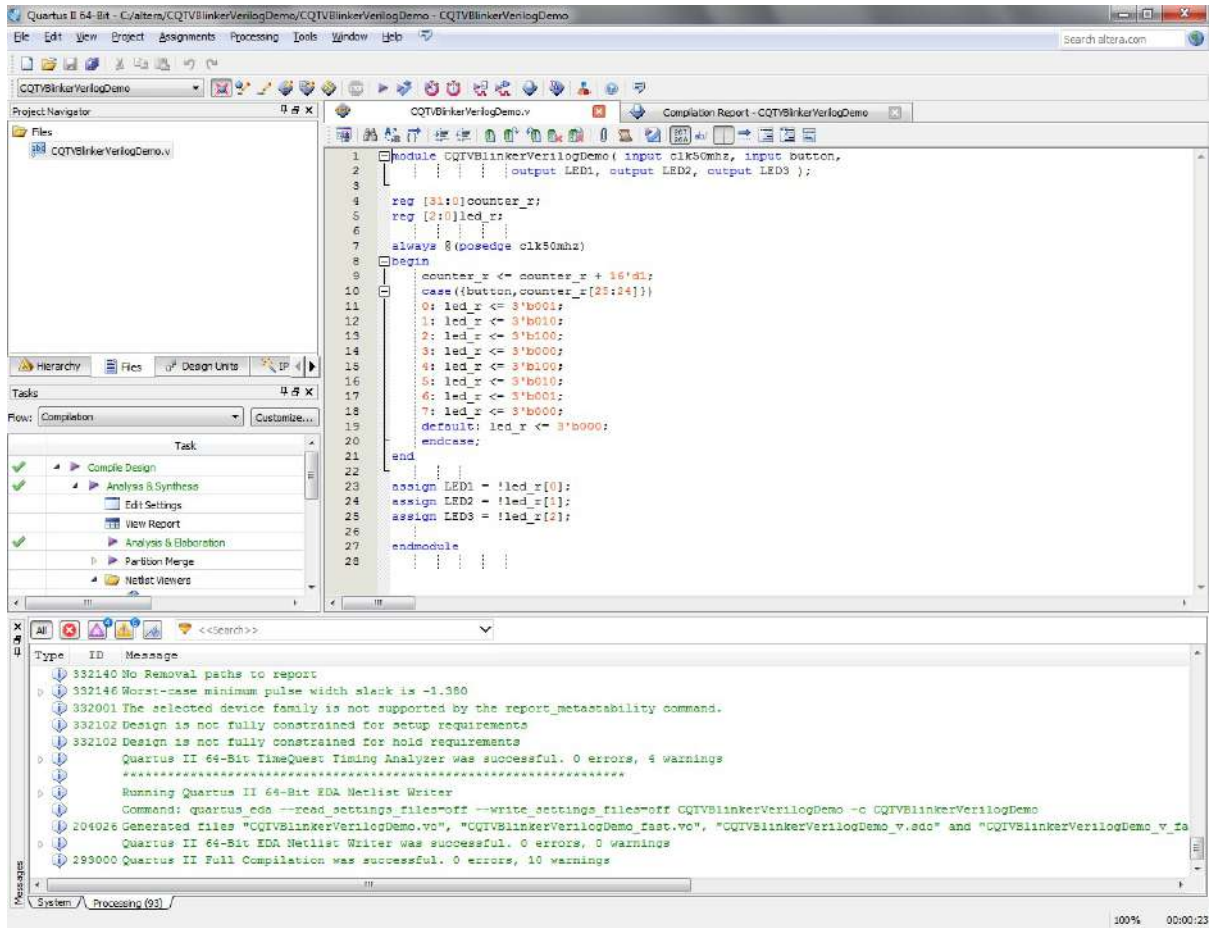

Illustration 1: Quartus II GUI



Illustration 2: FPGA Development Board

What to buy

So now that you have a brief overview of what an FPGA is I will go on to tell you what you need to buy to get started configuring these chips.

Put simply you require 3 things.

- 1) Quartus II free web edition, which can be downloaded from www.altera.com
- 2) Altera USB Blaster and
- 3) Altera development board.

Items 2 and 3 can be bought cheaply from China. I usually choose the cheapest supplier I can from mainline China, preferably one with a make me an offer option. The Blaster is required to download the code from your PC to the development board and can be used over and over again. There are a huge range of different looking Blasters but they all do the same thing, these should cost you between £7 - £8. As a guide I have included a picture of the one I use. The FPGA board you should obtain is one that has an EP2C5T144C8N on it and should cost between £12 and £13 pounds. This seems to be about the best value for money, again see the photo. Alternatively you can pay a bit more and buy these items from a UK based supplier.

If you become more serious in your FPGA ambitions you could try the range of kits from [Terasic Technologies](http://TerasicTechnologies) as well as selling boards they provide a range of specialist add on boards and a set of tutorials on how to get started. The tutorials / lab exercises can be downloaded from their site without having to buy any of their boards. Their kits include all the software and download leads you require, the Blaster is integrated into the board. Digilite-ZL uses their DE0-Nano development board. These are low cost but powerful boards and can be used for many applications.

Returning to the inexpensive board from China, it requires an external 5v PSU, it comes loaded with a program that strobes the LEDs. On the board as well as the FPGA you get a 50 MHz clock, push button, 3 LEDs, flash memory (so your design will run from power on) a JTAG socket and an AS socket (active serial, for programming the flash). All of the usable FPGA IO pins plus various voltages are brought out to pins on the edge of the board so you can hook up your own circuits. The I/O can be configured for a large number of standards and voltages. The internal PLLs and dividers on the FPGA can generate a large combination of clock frequencies derived from the 50 MHz clock on the board.

Where is the technology heading.

Gate geometries are getting smaller, the chips are becoming bigger, faster and more custom function cores are being added. To me the most exciting development is the introduction of devices like [Altera's SoC \(System on a Chip\)](#). The first of which includes a dual core ARM9 and Cyclone V FPGA device on a single chip. Terasic do an inexpensive [Terasic SoC board](#) for this chip which can run Linux on the ARM and your own design on the FPGA. This brings the advantages of both FPGA technology and that of a dedicated hardware CPUs to a single device with blindingly fast communications between the two parts.

What are the downsides of FPGAs.

The major downside of FPGAs I think is the fact that most of the interesting IP (Intellectual Property) cores (like MPEG and DVBS-2 encoders) are not free or even cheap. There are some open source

projects that provide free IP cores but I stick with doing everything myself. Altera do provide some free ones using their MegaWizard tool but they are mostly for simple functions like multipliers and memory FIFOs. Other cores they provide are evaluation ones and can't be distributed.

For high volume production the chips are relatively expensive and consume a fair amount of power in this case an ASIC would be more appropriate. However as Amateurs we are not in the high volume business.

You need a different way of thinking about a problem when you program a FPGA. You have to search out the parts of a design that can run in parallel. This may well mean that some well known ways of doing things in the CPU world are no longer appropriate for the FPGA world. You have to start thinking in terms of clock edges rather than instruction cycles.

Please don't let me put you off trying FPGAs. If you want you can consider them as your entire junk box of TTL chips crammed onto a single chip and design accordingly.

In the next article

In the next in the series I will dissect a simple FPGA design that you can use as a template for your own designs and I will discuss the basics of Verilog with you. I will also provide a complete project file for the design which will include pin definitions etc. In the final article a much more complex ATV related project will be presented. Then if there is enough interest I hope to present the occasional FPGA related project.

INTERESTED IN VINTAGE TECHNOLOGY ?

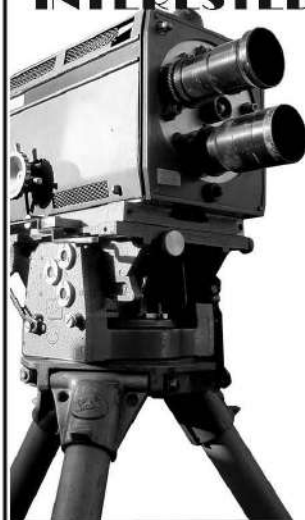

Subscribe to AIRWAVES

The bi-monthly catalogue magazine for vintage technology enthusiasts. Contains items for sale, plus articles on the history and restoration of old equipment.

Send an A5 S.A.E for free sample copy and subscription details to:

On The Air

The Vintage Technology Centre
Th Highway, Hawarden

(Nr. Chester) CH53DN

Tel: 01244 530300

Email: info@vintageradio.co.uk

Website: www.vintageradio.co.uk

❖ WIRELESS
❖ TELEVISION
❖ GRAMOPHONES
❖ AUDIO & VIDEO
❖ STUDIO EQUIPMENT

A collection of vintage audio and video equipment, including speakers, a gramophone, and a television set, arranged on shelves and a stool.

BATC Training – The Digital Studio. Part 2

By Mike Cox

In Part 1, it was indicated that Part 2 would cover a bit about audio, equalisation and distribution, and the bare bones of HDMI. A wide brief, but here we go!

Digital Audio takes many forms, [like video, really]. There is parallel audio – straight from the analog-digital converter [ADC], there is serialised audio, up to AES/EBU coding, and then there are the

compressed audio formats such as .WAV, MP3 and others.

Before we get too far, there are some differences between video and audio when it comes to digital conversion. As stated in the previous article, frequencies above about one third of the sampling frequency need to be removed at the input to the ADC. Thus a sampling rate of 48 KHz needs to restrict audio bandwidth to around 20 KHz before the sample gate.

Note that Audio has no dc component; its waveform is symmetrical about the zero volts line. This is known as a bipolar signal, and is achieved by inverting the Most Significant Bit [MSB] from the converter [Fig. 1]. Thus a zero audio signal [silence!] is represented by 1000000 for an 8 bit digital signal, or 80h.

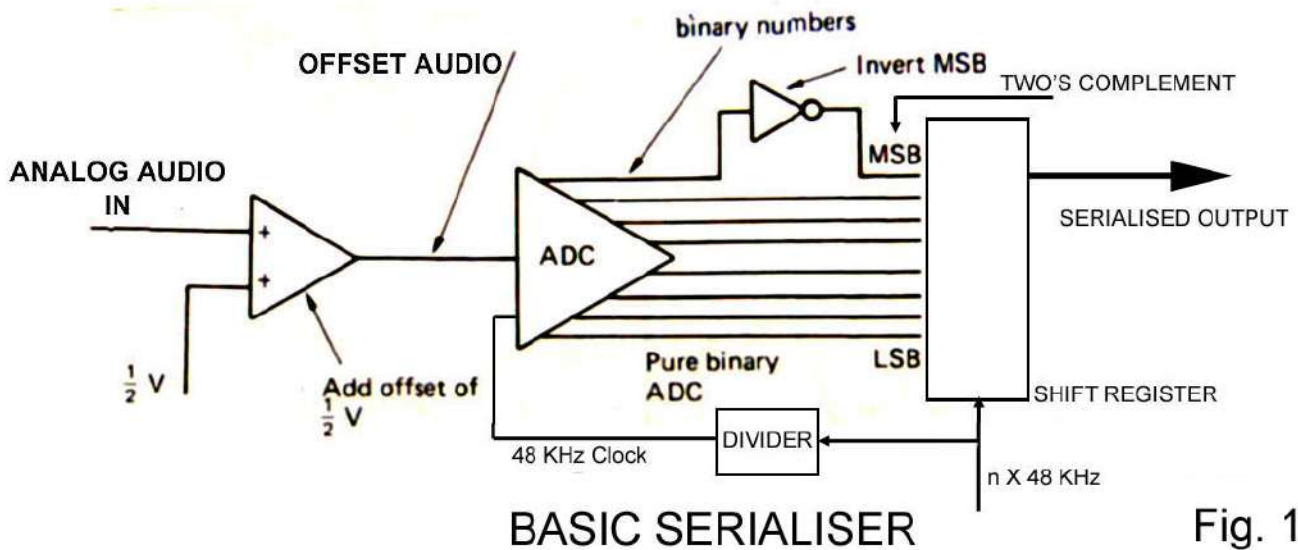
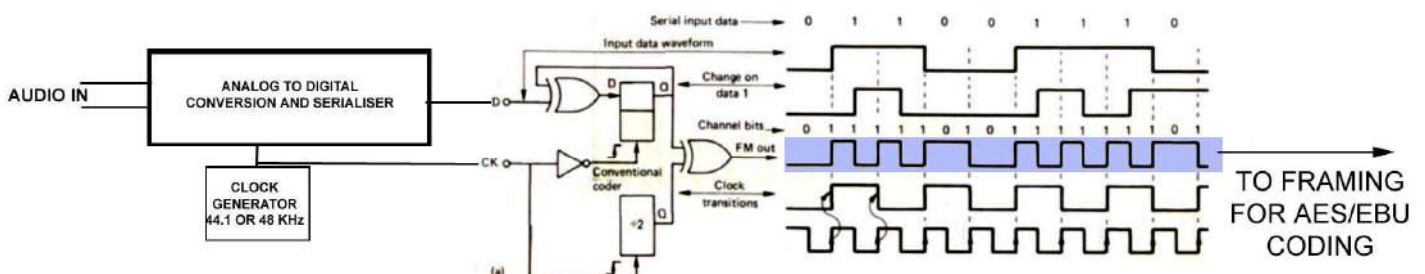

Fig. 1

Practical distribution dictates that the parallel stream is serialised, because with up to 24-bit audio, 24 core cable is tricky! And as we will see, unnecessary. Serialising involve switching each output of the ADC to line at a frequency equal to

the number of bits times the clock. In the case of 48 KHz sampling and 24-bits, the bit rate will be 1.152 Mbits/second – quite fast. Also we have not yet allowed for sync bits, status bits and all the O and S that make up the stream.

We see straight away a problem, because there are no sync periods in audio, and we will need to recover a clock signal to decode the stream. So the common form of coding is Manchester Coding or Bi-Phase Mark [Fig. 2].



BI-PHASE MARK CODING
FIG. 2

However, before we can use such a signal, it has to be formatted with a frame structure. This is shown in Fig. 3. Usually, there are left and right sub-frames,

together with various bits for status etc, each frame being repeated at 48 KHz. Although it is possible to assemble an audio codec [as these devices are called],

it is hard work, and unless you are determined to get to the bottom of audio coding, it is better to buy a proprietary chip that will do the work for you.

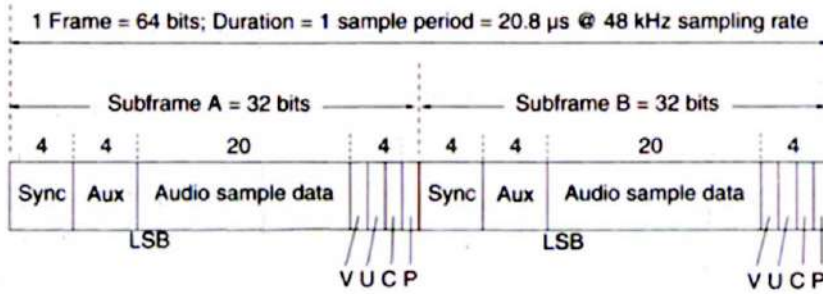

Format of the standard two-channel interface frame.

Fig. 3

Digital signals have to be distributed from source to perhaps several destinations. In doing so we are bound to use some form of cable. This will doubtless be lossy, which will limit the cable run unless some form of equalisation is used. SDI [270 Mbits/second], using the highest grade of coaxial cable, will travel about 300 metres before the signal degrades. A typical

cable is the Belden 8281. This has a flat loss of 0.8 dB per 100 meter run, increasing to 2.6 dB at 10 MHz, and 9.8 dB at 135 MHz, so our equaliser has to work quite hard. With HD SDI [1,485 Gbits/second], the run will only be 150 metres. Equalisers can be simple, or they can use re-clocking to ensure a pristine signal for onward transmission. The

previous article [CQ-TV 240] described a typical SDI encoder, and showed the waveform from such a device. Fig.4 shows a simple SDI equaliser using a Gennum chip. Note that this is not a re-clocking system. Fig. 5 shows the output stage for the equaliser, or for a routing switcher.

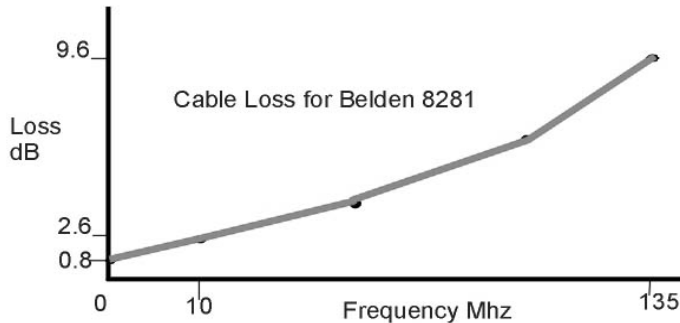

June 2013

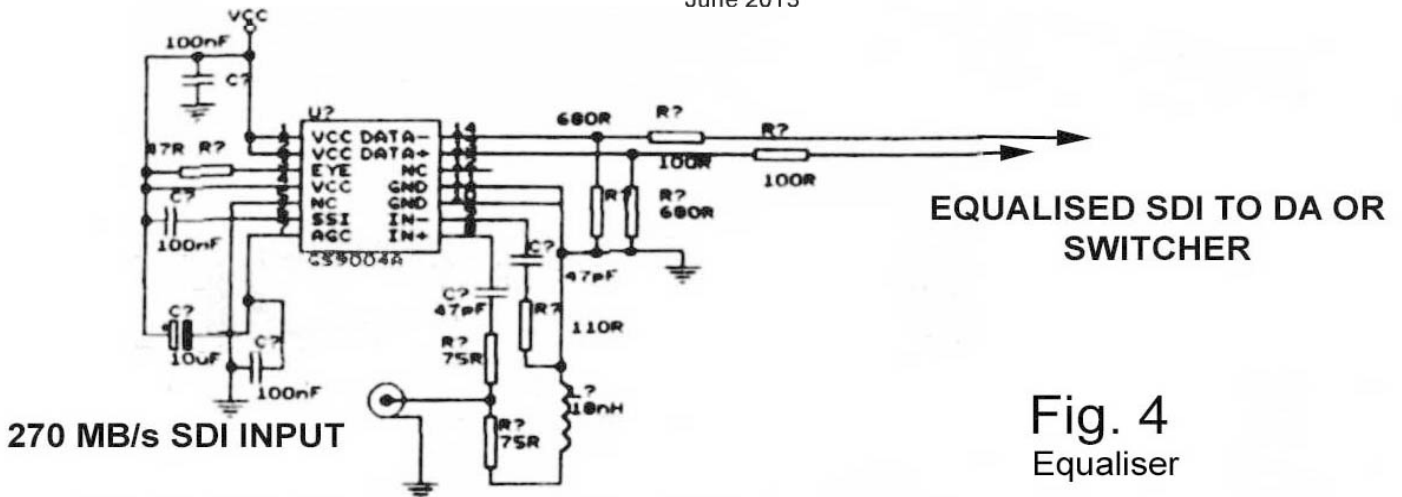
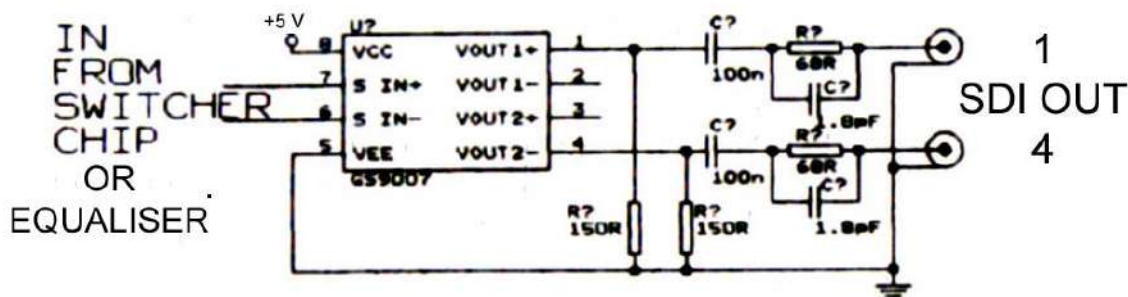

Fig. 4
Equaliser



SDI DISTRIBUTION AMPLIFIER
UP TO 4 OUTPUTS

Fig. 5

Chips are available containing both an equaliser section and a re-clocker, albeit more expensive. These contain a phase-locked loop to regenerate the clock from the input SDI signal, and then latches the signal again before the output stage.

Fig. 6 shows the block diagram of a typical equaliser/re-clocker, Genum **GS9005A**. Although these chips are pretty ancient, and Genum has been bought out by Semtech (qv), Ebay was offering some today.

Fig. 7 shows a simple equaliser and DA with 3 outputs that I made for use at IBC, which was my introduction to SDI. We were starting to use SDI at IBC for distributing the Info Channel to various displays around the Show. There was one long route to a projector which was very

suspect – picture drop out etc. I had not made the equalisers yet, so what to do? The projector was driven with RGB and sync signals from an SDI decoder. We found a 50 meter length of RGBS cable, cut the SDI cable back by 50 meters and moved the decoder. Job done!

This is a good illustration of the sudden degradation of a digital signal, as against the gradual decline of an analog signal. Texas Instruments [qv] do a range of SDI interface chips, among them the **LMH0394** that will equalise HD-SDI signals at 2.97 GB/s on 150 metres of Belden **1694** cable. Pity it is **WQFN** package. [See below]

Before we leave SDI, It's worth mentioning that 4 channels of digital audio can be sent as an integral part of the SDI

stream. Chipsets are available for insertion and de-insertion at the receive point. For further information, see the reference below [Digital Interface Handbook]. The latest chips use very small packages with 0.5 mm pin spacing and are getting near the limit for amateur assembly. This is a problem that is increasing, and unless you have a tame X-Ray machine to check whether the Ball Grid pads have soldered properly [BGA chips may have 100 or more pads to check, and they are under the chip – not visible], you are taking a gamble when you assemble such a device.

Perhaps we all have to become systems engineers, and not deal with the circuitry, which is a shame.

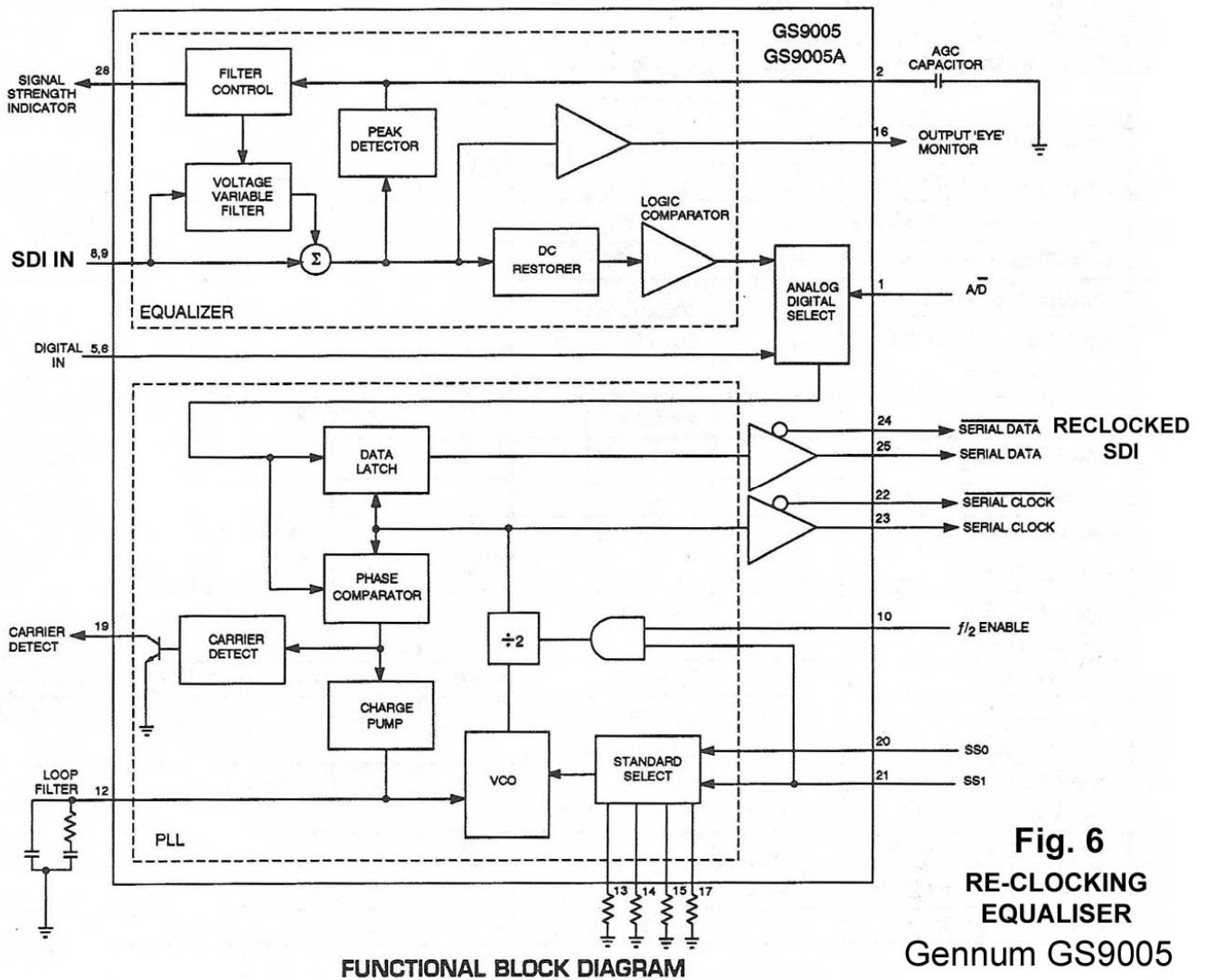

Fig. 6
RE-CLOCKING
EQUALISER
Genum GS9005

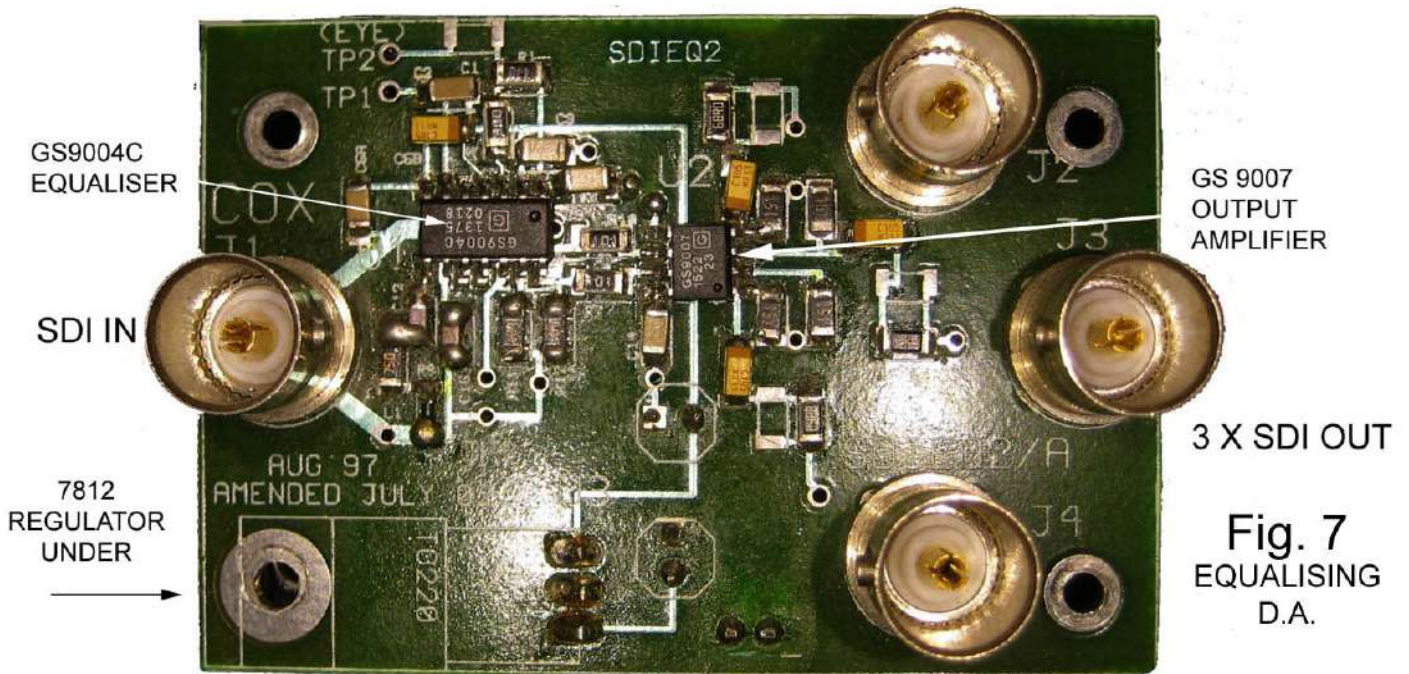

Fig. 7
EQUALISING
D.A.

This is a good point to talk about **HDMI**, which is becoming the interface of choice for much video equipment. It can be considered as the digital equivalent of the **SCART** connection. HDMI was introduced in 2002, and has gone through various iterations since then. The current version is 1.4b and version 2.0 should be out soon.

So what is HDMI? It consists of 4 shielded pairs for the main signals [and clock], and some auxiliary conductors. The A

connector has 19 pins; there are miniature versions that are used with camcorders and still cameras [C and D in **Fig. 8**].

The main signals are balanced serial video [for RGB or YpbPr] with a maximum bit rate of 10.2 Gbits/s, giving a maximum analog video bandwidth of 340 MHz. The terminology for the signal transmission is Transition-Minimised Differential Signalling [TMDS]. Audio is interleaved in the blanking intervals of video, and up to

8 channels are available. In addition, audio streams such as Dolby DD+, TrueHD and DTS-HD bit-streams can also be transmitted. Serial control signals are also sent, as is a modest amount [50 mA] of power. The talk in the press is whether the current version is suitable for 4K resolution UHDTV, or do we have to wait until HDMI 2.0 is released. Sony are said to be selling a 4K display for home use around now [June 2013], with special Blu-Ray discs mastered at 4K, but at 24 frames/second.

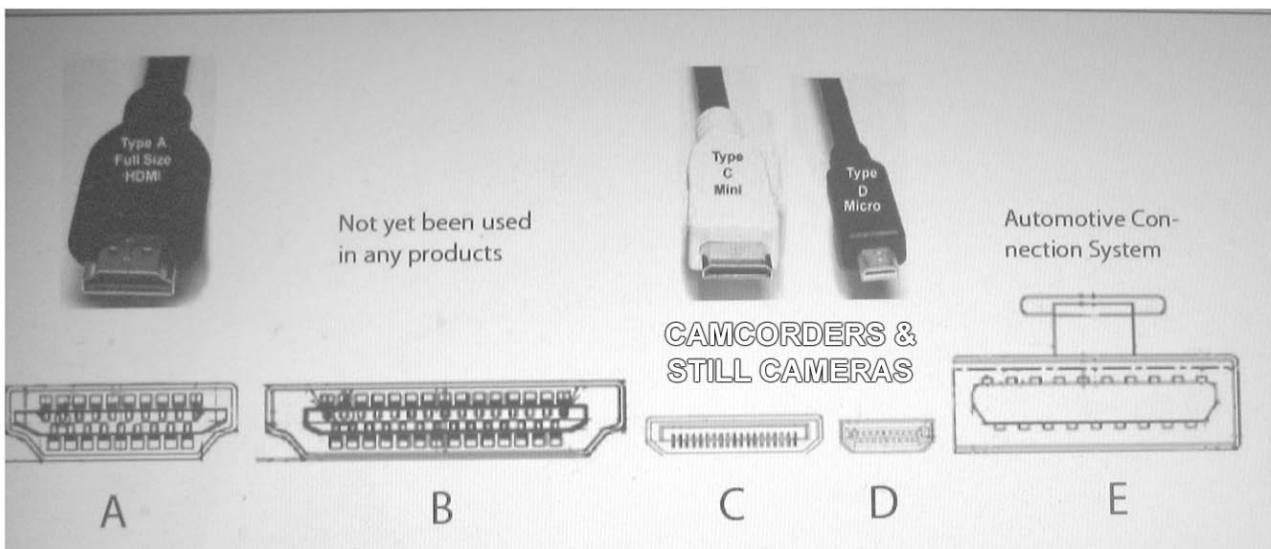

Fig. 8 HDMI CONNECTORS

With the HDMI 1.4 data rate [10.2 Gbits/s] signals don't travel very far – about 5 meters for reasonable quality cable. For domestic use, this is probably far enough, but you may remember that in CQ-TV 238, there was an article about Shelwood Productions studio in Thames Ditton, and their use of a Black Magic mixer with HDMI inputs. The 5 meter limit was an issue, and repeaters were used.

There is a technique for longer distances [50 – 100 m.] using CAT5/6 cable that is worth looking at. Most units need 2 runs of CAT5 cable, but there are some that use only one run. However to equalise 50 m of cable is not cheap. Units are offered at prices from £17 to £160.

Texas Instruments offer a repeater chip **DS16EV5110A** in a 48 pin WQFN

package [7 mm x 7 mm] if you want to build your own repeater. It will cater for more than 20 meters of 28 awg HDMI cable at 2.25 Gbps speed [per channel].

Fig. 9 shows the internals of the repeater chip

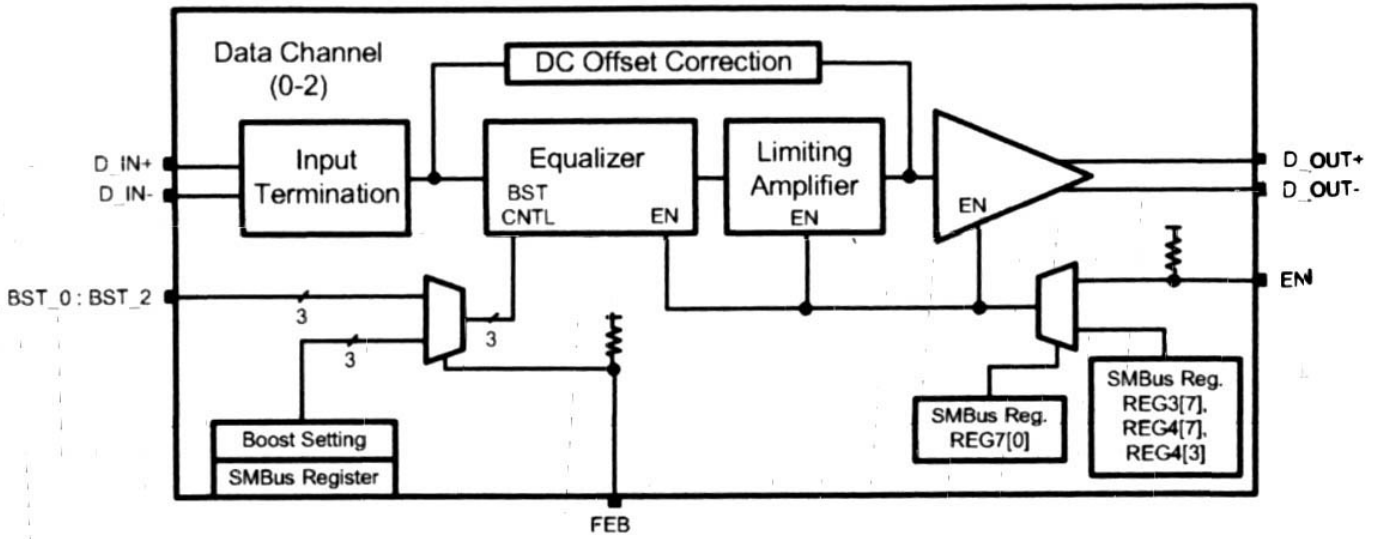

DS16EV5110A Data Channel (One of three)

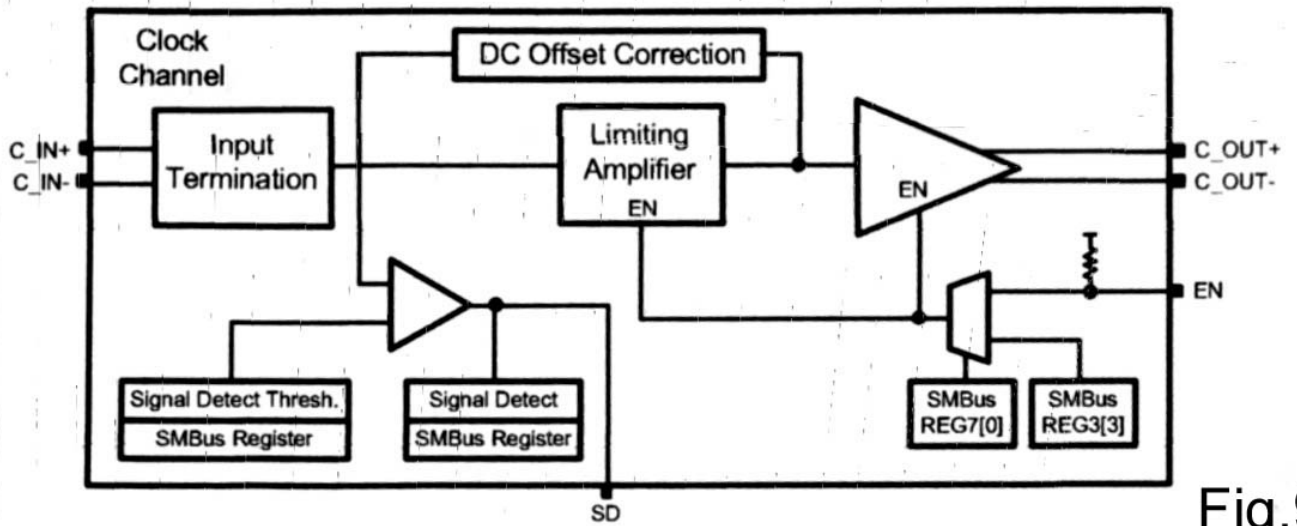

DS16EV5110A Clock Channel HDMI REPEATER

Fig.9

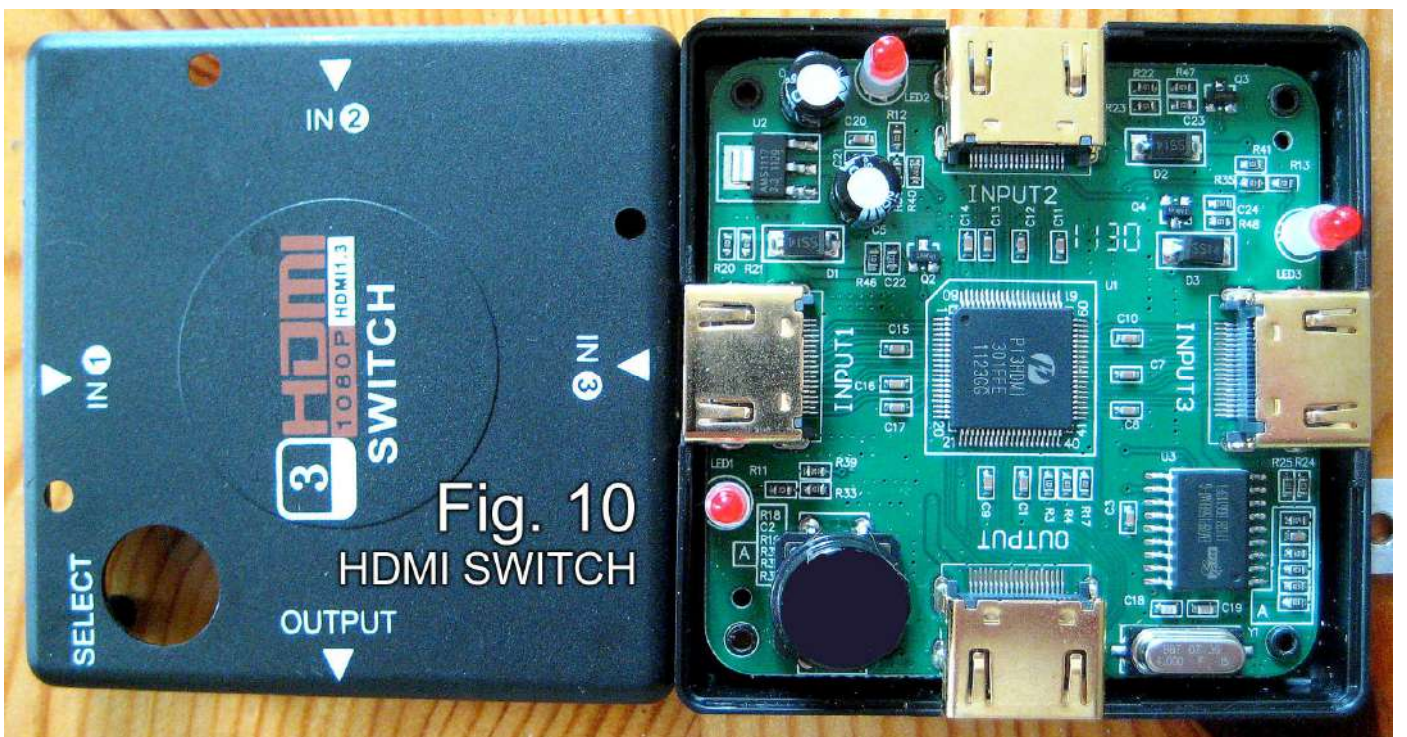

Fig. 10
HDMI SWITCH

Texas also offer a 3 x1 crosspoint chip [TMDS361B] as well as a simple buffer type chip for in-set use [TMDS141]. Fig. 10 shows a typical 3 to 1 switch, although not using the Texas chip.

It is essential that any repeater is HDCP [High-definition Digital Content Protection] compliant, or you may get a rather low resolution picture. The MPAA is paranoid about being "ripped off", and it is written

into the HDMI specification that the source checks to see if the destination is compliant.

There is an abundance of ready-made cable about, and 1 to 2 and 1 to 4 splitters are also available from many sources.

In this part we have skimmed over a few further facets of digital television and its distribution. Now that the national TV

coverage is entirely digital, there is much more kit around to play with.

Unfortunately, Moore's Law about storage doubling every two years means that chips get smaller, and that can pose a real problem for the keen amateur builder.

So buy yourself a powerful magnifying glass, a fine pair of tweezers and have a go!

References

HDMI Interface chips:

www.ti.com

www.Analog.com

SDI. General:-

Digital Interface Handbook
Rumsey and Watkinson
Focal Press
ISBN 0 24051909 4

Chips:

www.semtech.com [Gennum]

Audio:

www.ti.com

www.analog.com

BATC Contacts

Tel: +44 (0) 1400 414 243

Web Sites:

Postal address:

<http://www.batc.org.uk>

BATC

Silverwood

South View Road

Pinner

HA 5 3YA

United Kingdom

<http://www.batc.tv>

<http://www.DxSpot.tv>

E-mail: See page 4.

Setting up a virtual studio.

By Mike Saunders, G8LES

Firstly let's look at what I will cover and what is beyond the scope of this article. We will look at the simplest way of doing this, but we will only look at a still presenter position. I will relate it to how I have done it; it's a matter for you to decide which particular piece of hardware you use to fulfil the function of any particular box on any of the diagrams.

There was a rather grainy TV set at the bottom of the picture which I have covered up with a new TV and written my call sign in there. All the modifications were done to the picture above in Adobe Photoshop. The TV set picture is something I found on the web, and I changed its aspect to 4 by 3 to enable the insertion of pictures. The top TV could have been angled but then all the pictures would need to be the same shape – too much hassle.

So to complete the set-up, the presenter sits on the right.

We are going to need to sit in front of a green background and key the green out so as to only see ourselves, and the studio will be behind. We also need to set up a mask, as we want to cut off at the desk, and have an addition of a green painted board on the table to follow the curvature of the desk.

My physical set up is below and I finally plucked up courage to paint the lounge wall green. For those of you with domestic customs in the house you will probably need to buy a green cloth and a batten of wood or even better a proper stand, otherwise you might find your clothes bag on the front door step after doing the wall painting.

Dulux Woodland Fern 4 in shop mix is the right colour paint, or buy a cloth set up from say 3D Broadcast sales at about £92.

My set up with the painted wall mentioned above is shown below.

A roving camera and tracking graphics like we see on TV are outside the coverage of this article. To do that requires camera sensors and emitters round the set so that the software knows where the camera is and where it is pointing at all times, this gets very expensive, very quickly.

Now, firstly we need some graphic to use which will represent the studio. I needed to spend some time finding something on the web which I could modify and I found it, as below





The angled green bar matches the graphic curve on the desk and to which houses the remote control box is fixed we see the other side below. The rear of the bar is not painted green to avoid reflection in the laptop lid.

It is fairly self-explanatory on the labelling. If the mixer cut button is pressed it switches out the chroma key and graphic BG and shows the IO output from one edit suite to play a video. The Edit suite start is a SMD relay across the space bar contacts on the edit suite keyboard. Now this presenter position is designed to operate with one person, so the left hand is on the mouse wheel for teleprompter speed, the right hand is changing the picture inserts as instructed on the teleprompter text.

Now we look the other way to see what the presenter is seeing, and you can see the Teleprompter and camera as well as the comfort monitor showing the final picture. The Angled glass, camera mount and monitor I was offered second hand.



Now I have mentioned prompters, that was another exploit to find something that worked on MS Windows 7, that wasn't too expensive and could utilise the mouse wheel for speed and the TV out from the laptop. I tried ProPrompter, UPrompt, and Telescreen but with my laptop I am using the text was jumpy going up the screen instead of a smooth scroll and it put me off reading from it. I rather liked Prompt Dog, as it was laptop and TV out resolution independent using the extended screen mode and only \$59.95 to buy and it was smoothly moving the text. It also works on Apple OS 10 to go with say an iPad.

The PromptDog trial doesn't work with "dogtrial" as they suggest on the website but "fetch_trial" does work. It's nice in that by flicking the mouse wheel in the opposite direction it flicks back a few lines in case it was going too fast for the reader.



There is however a bug in the software, with a long script such as the RSGB NEWS, which I have a script here at 2,406 words. It refuses to scroll on the desktop PC with the font size greater than 54 and on the laptop greater than 65. On short scripts this bug does not appear. I have written to them to fix it, as of January 2013. File types: *.txt files only. I was going to settle on Teleprompt 32 the only snag with that being that the LCD screen resolution has to be set at 800 by 600 when using TV out, and its a lot more expensive, but now I can utilise PromptdDOG with the font size settings as described, I prefer that and it moves the text up the screen reasonably evenly, and utilises the mouse wheel well for speed, as well as including a text editor. <http://www.promptdog.com/>

So now if you have put in place what I have said so far, we are pretty well set up. But how are we going to generate the graphics to insert on the picture? You could use Ms PowerPoint as a source into a vision mixer and use the PAL TV out from the PC and it must switch undetectably between slides on mouse click, which actually PowerPoint does do well.

Each slide must contain the virtual studio shot, as a constant, so copy the first slide lots of times. Here the studio shot needs to be a *.png file which preserves layers, and set the monitors to be see through (erase the black screen area in Adobe Photoshop or photo editor) and general *.jpg pictures of interest are resized and sent backward a layer. For those not familiar with PowerPoint (2010) select the picture tools tab and turn on the selection pane to select the pictures from the list, otherwise PowerPoint will automatically select the studio picture filling the screen and not the ones behind. PowerPoint can also be set to output to the second

monitor in the slide show tab in the monitors section – use the “show on” drop down and change it to display on the secondary monitor.

If your PC TV out from the video card doesn't fill the screen use either a VGA to video converter or DVI to TV out box which does as a second monitor. If you already have a second monitor you will also need a monitor signal splitter.

So now we have a source of graphics from a desktop computer, a teleprompter and add to that our camera, we now need a mixer with a chroma-keyer built in. Firstly the highest quality low noise connection you can make to the mixer the better. Digital is best, next component video, next S-video or Y/C lastly its composite video. Ultimatt DV at http://www.ultimatte.com/UltimatteMain/dv_Main.html looks a good device, but including the VAT its £2132 from one supplier or £1980 from Libra Broadcast which isn't cheap for a brand new one. Despite the price shock, I thought that the

manufacturer's diagram explained things nicely as below.

In our case the DVD player is our desktop PC. The advantage of these dedicated hardware devices, including the Panasonic MX30 and MX50 and MX70 mixers is that they contain a framestore and there is no need to have a genlocked camera. However the inclusion of a framestore to resynchronise the signals, does make the electronics more expensive, in order to cope with common asynchronous sources. The MX30's are however going for about £250 on eBay so not too bad after all.

The only thing we haven't covered is masking the key camera. Fortunately my ForA VPS300 mixer has a matte than can be applied to the chroma key and it has variable crop that can be applied to the matt. However in our amateur world to need a piece of dark, preferably black card to mask the camera lens, and you will need to set the camera to manual iris and focus. It automatically gives a soft edge to the mask doing this.



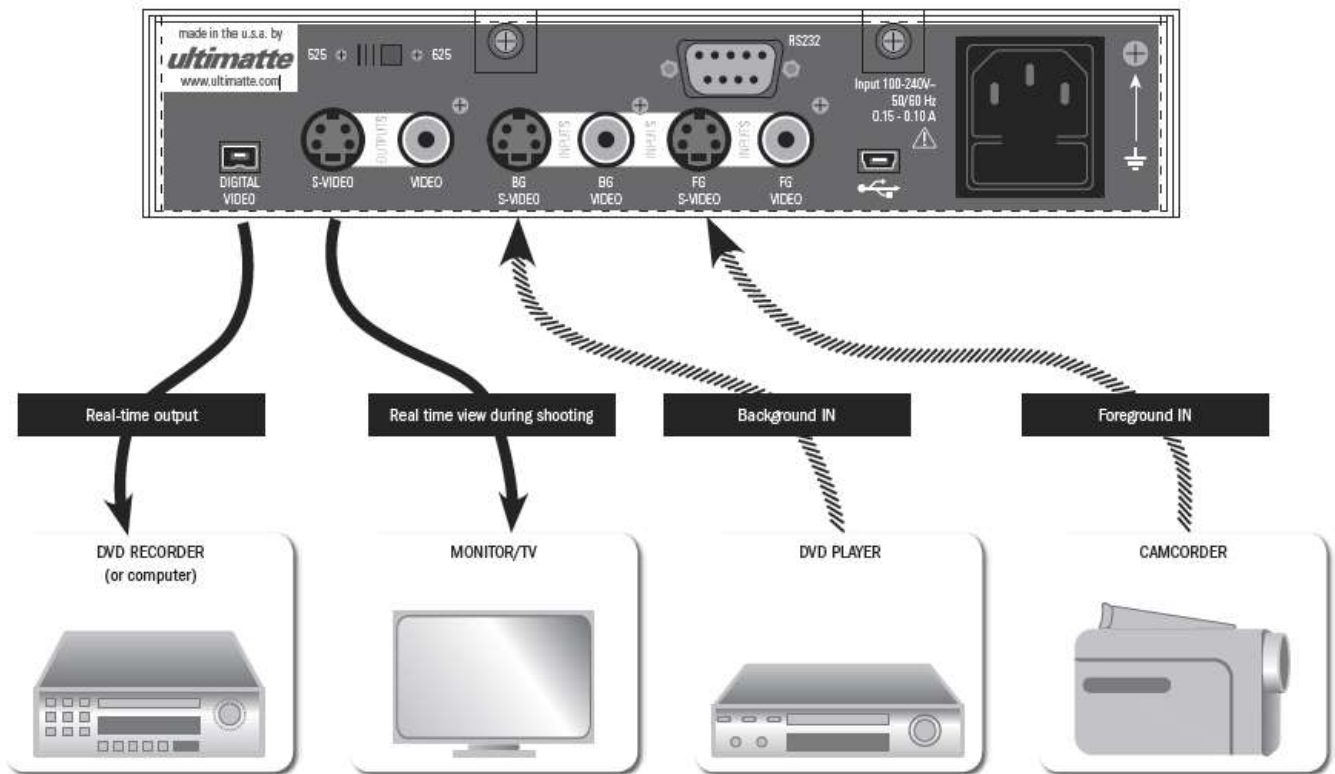

The mask crop can be set up in the menu by pressing the shift button and mask 1 button on the top row of small green centred buttons which are just off the left side of the picture. So, we want to end up with the red area masked out as shown here. This is so that we look as if we are sitting behind the desk our actual table disappears and our legs, and it means or green screen cloth can be a reasonably manageable size bearing in mind we need to be zoomed back to get our relative size right.

If you think about it, it does in fact equate to a corner wipe, but the mixers mentioned above (I have an MX50 as well) did not have wipe and chroma key functions allowed to be active at the same time..

The only other way of solving this electronically is a second mixer in between the camera and the keying mixer with a wipe set up as above so the red area shows as black would also solve the problem, and be better than the piece of card.



My graphics PC has a G2 systems (Were in Farnham Surrey – now closed down) Televisor Junior card which has a ribbon cable across to the Matrox AGP card. It has two main modes mixing and keying via a remote control which we can see below are full screen or key mode and it will key on black.

I have spotted the TV One C2-260 which fits inside the PC and takes an external Composite or S video input as Genlock and adds it to your PC screen output.

So in the drawn TV's in the virtual studio shot on the first page of this article, with the G2 Televisor, which look like it works similarly to the card above, I can key through another live image via this genlocked overlay card which is fed with my MX50 mixer.

The last item to get is a decent quality UHF radio microphone and receiver and you are ready to go.

C2-260 with Breakout Cable Attached

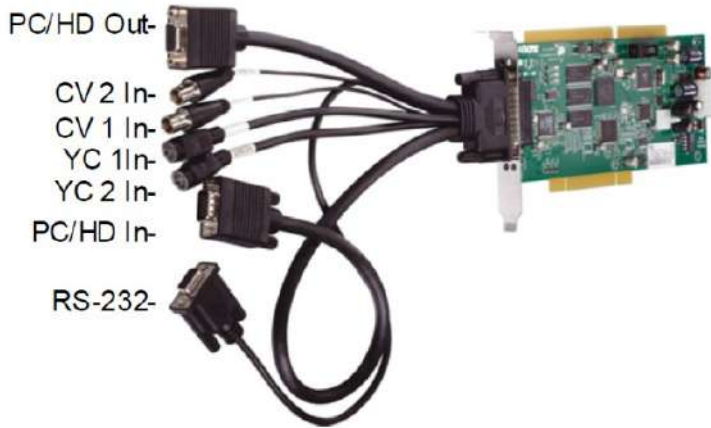

Sample Windows Control Panel Menus

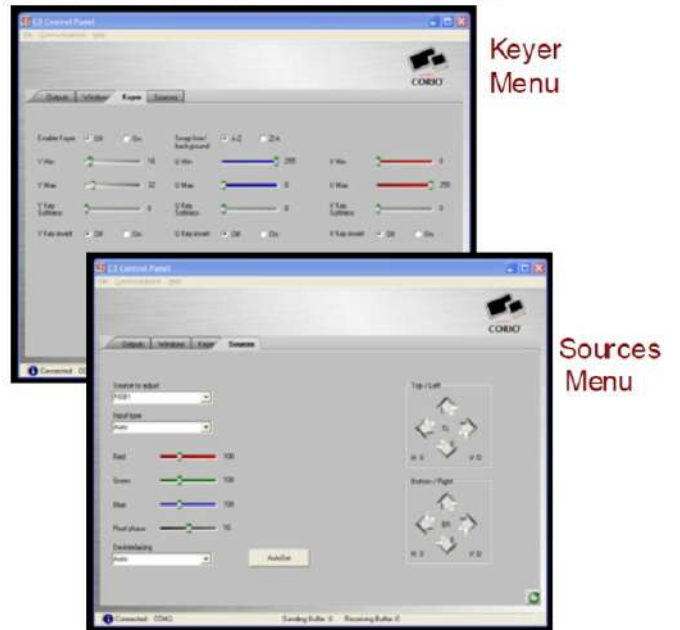



Here is the final result. Happy presenting, Mike, G8LES

BATC Contacts

Tel: +44 (0) 1400 414 243

Postal address:

BATC
Silverwood
South View Road
Pinner
HA 5 3YA
United Kingdom

Web Sites:

<http://www.batc.org.uk>

<http://www.batc.tv>

<http://www.DxSpot.tv>

E-mail: See page 4.

History of Television, Monoscopes and Test Cards.

by Brian Summers G8GQS

In the late 1940s and 1950s television broadcasting was expanding rapidly and there was a need for test signals and test cards. In addition to use in the studio, transmitters often radiated a test card. In the UK the test card 'C' was transmitted

each weekday for the benefit of the radio industry and trade. The traditional solution was to place a physical card in front of a camera and use that as a picture source. This was not entirely a successful solution. There were the technical

problems of camera alignment and card positioning and more importantly it tied up an expensive camera that was not then available for use and consumed its tube life.



An early shape Monoscope tube by Cathodeon

The French tube type TH.9500 from Thomson Houston had a long thin gun and a cylindrical body. A wide choice of standard patterns were available together with specials to order! The Monoscope cameras were made by Pye, RCA, Marconi and others. Marconi made a portable cased version for OB use as well as the rack-mounting type for studio use. Simpler cameras were made for non-broadcast use in manufacturing and service shops.

An RCA type 1699 Monoscope tube >

The scanning requirements were quite modest and a standard deflection yoke could be used. The rest of the tube connections were much like a picture monitor except that the target was at 0 volts with the cathode at some 1200 volts negative, with the rest of the electrodes at appropriate negative voltages.

Operation

The Monoscope camera is a simple device, the principle controls are; gain, beam current and a black level adjustment. The beam current control being advanced to a point where the picture appears in conjunction with the gain control to set the output amplitude.

Monoscope tube construction

Tubes are quite simple in construction. The glass envelope and gun assembly are similar to a 5 inch round C.R.T. (Kinescope). The target is an aluminium plate fixed inside the front of the tube by some metal spring clips and its output connection is a small metal "pip" in the centre of what would have been the faceplate. The target is printed with

To preserve tube life it was recommended that the beam current is no more than needed and the gain set for the correct level output consistent with the amount of noise present. The scan controls were adjusted so that the test card filled the picture correctly.

Once the monoscope camera was up to temperature it was quite stable in operation, at least when they were new. Half a century or more of use/disuse has not helped them. The broadcast versions had connections for external drive pulses, line drive, field drive, mixed blanking and mixed syncs. For the rack mounting versions an external HT power supply was the norm.

ordinary printers ink in the desired pattern. The tube is heated during manufacture, this reduces the ink on the surface to practically pure carbon. The difference in the secondary emission ratio for the pattern or metal creates the output current, which is in the 0.3 to 0.7 μ amp range.

The solution to these problems was a special cathode ray tube that became known as a Monoscope tube. This tube was similar in many respects to a conventional CRT except that instead of the normal phosphor coating inside the glass there was a metal target that had the desired pattern printed on it. The output was taken from a connection to this target via a button connector in the centre of what would have been the tube faceplate.

Early tubes came in a variety of shapes and sizes, but in the UK & USA they soon settled down into a tube that was similar to a standard 5 inch round camera viewfinder tube.



Marconi BD665 Monoscope camera & power supply

The final anode, which collects the secondary electrons from the target, is biased approximately 30 volts positive with respect to the target.

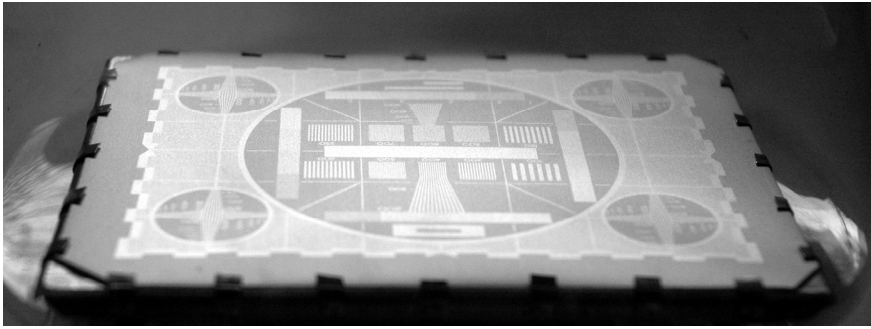

In a 1952 paper by R. D. Nixon a method was described; *employing light-sensitive fish glue as the printing medium, in conjunction with fine halftone screens, has been found to give superior results to direct or off-set printing with inks. The use of silver as a base material, instead of the more commonly employed aluminium, results in picture reproductions free from spurious signals.*

A Monoscope target looking, through the tube side

Safety Notice

If you decide to work on a Monoscope camera, you should be aware that all valve type equipments have an interesting selection of high voltages in them. **If you**

are not trained in safe working practices, you should NOT be working on this type of equipment. Also note that the wiring practices of the 1950's are

a long way short of today's standards. The use of a mains isolating transformer is recommended. You should not work alone!

Restoration

I start with a good clean up, IPA Isopropyl Alcohol, is a useful solvent in a well ventilated area. Cotton buds and baby wipes are handy too. This is a good point to take detailed photos for later reference. Small parts like knobs, valve cans can be removed for cleaning. Put right any mechanical damage.

The valves themselves can be removed for cleaning. Do take great care NOT to rub the valve markings off! If this should happen write the number back at once with a fine felt tip pen. Valves are fairly reliable but check the getter is not white and the pins are not covered in corrosion. I do not habitually test valves in a valve

tester, if there is a suspect substitution is a quicker than a test. It is quite OK to use equivalents indeed there may well be equivalents in it as received. Substitution by a near equivalent needs to be done on a case by case basis, examining the published valve parameters.

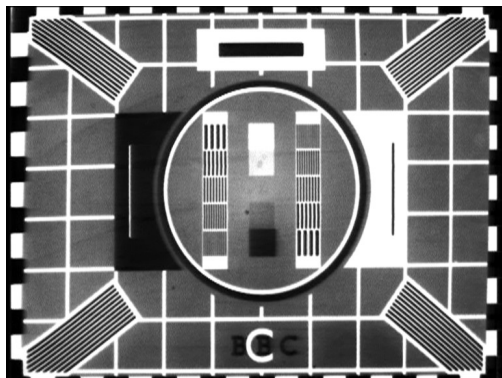

BBC test card C

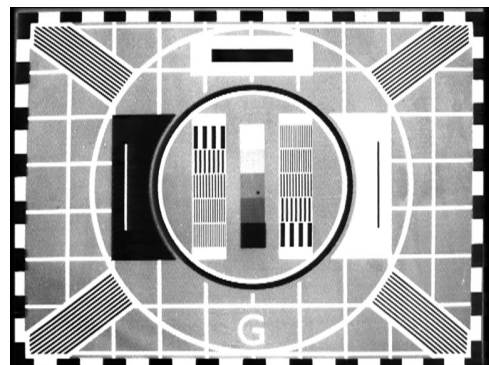

Test card G

Monoscopes cameras tend to be well made with quality components and the valve bases give little trouble. Only in extreme cases will they need cleaning. Use the IPA and an old valve wriggled in the socket to clean. Other plugs and sockets clean as needed. Most old connectors can be sourced with perseverance. Avoid at all costs the temptation to change the connectors. Do not solder to the pins, if a temporary connection is needed, a wire with a Hellerman sleeve is good, or a single socket/pins salvaged from an old plug can be used with better reliability. The correct plug/socket will be found in due course.

A unit of this age will have all the problems you might expect with leaky capacitors and resistors high in value! The place to start is with the main electrolytic capacitors. These were quality items and with careful reforming they can be nearly as good as new. Depending on

the circuit it may be necessary to disconnect one connection so that the leakage current can be monitored. I am very reluctant to replace these electrolytics as they are very visual and a 99% success rate can be achieved with reforming. Small paper coupling capacitors are a different story, most will be leaky to some extent and, with a few exceptions, will need to be replaced. It depends where they are in the circuit. Grid coupling capacitors are critical and no leakage is permitted.

At the other extreme a leaky capacitor decoupling a cathode resistor, of say 5K ohms, it's leakage has no real effect, providing of course it is still a capacitor! Resistors are the next for examination. There were two main types, wirewound and carbon composition. The wirewound ones, often the green enamelled power types, have a habit of going open circuit and will need replacing; they don't often

drift in value so it's a go no-go for these. The carbon composition resistors do tend to go high in value, but as most of them were 20% tolerance when new some considerable change in value is permissible. I have found the higher value ones to be more likely to be well out of tolerance. Again it is a case of accessing the effect of any changes. Wound components, transformers, chokes and coils are more of a worry especially if they have been damp. Make sure they are well dried out before applying power.

Results

I have a number of monoscope tubes, three of them work to some extent. I have a nice test card C tube with ITV as a logo. It has good emission but it has some intermittent connection in the tube base. I have reflowed the pins with no improvement and I am reluctant to remove the base in case the intermittency is at the glass pinch. Its picture is good

except for some spots that may be due to some contamination fallen on the target. Like camera tubes these should always be target upwards. There is also some unexplained shading in the central area. It is thought that this might be Helium gas poisoning. This comes about as the helium in the atmosphere sees the glass tube walls as an easy porous route to the

attractive vacuum within! I also have a BBC test card C, but worryingly the getter is going white, and a test card G tube. All of them display the central shading or darkening with some dirt spots. The pictures shown are untouched screen grabs of the Monoscope cameras output. Once warmed up the Monoscope camera is quite stable in operation.

References

"Television Engineering", Amos & Birkinshaw. Vol.1 page 79.

"The Monoscope", R.G. Dixon, IEE Television convention 1952 paper No. 1293

"Principals of TV engineering", Fink, Mcgraw-hill 1940, pages 116-7 & 494

<http://www.tvcameramuseum.org/pdfs/cathodeon/cathodeon%20monicon.pdf>

http://www.earlytelevision.org/experimental_rca_monoscope.html

<http://lampes-et-tubes.info/ct/ct041.php?!=e>

Practical television March 1951 reports that the BBC ordered 8 monoscope cameras from Marconi.

GB3IV Repeater



GB3IV regrettably lost its site on the Isle of Wight. They have now moved into this very impressive shack at the RNARS club

in Collingwood. The repeater equipment is located in a 19 inch rack in another room. This gives great scope for

experimentation and ATV events in the future.



Amateur Television Quarterly



Great articles on :

ATV

BALLOONING

ATV PROJECTS

Antenna Design for ATV

SSTV

ATV ACTIVITIES

Digital ATV

ATV On The internet

WorldWide ATV Coverage

USA \$22.00 year

Canada \$25.00 year

DX \$32.00 year (US \$)

Cyber: \$15 year



Published by ATV Quarterly

Cheques or Money Orders to

P.O.Box 1594

Crestline CA 92325

tel (909) 338-6887

Don't miss another issue

Subscribe Today

**Amateur
Television
Quarterly**

Volume 26 - No 3
MAY 2008
ISSN 0001-1472
SUBSCRIPTIONS
\$22.00 USA
\$25.00 CANADA
\$32.00 DX

ATV Activity at Dayton
Linearize your PA, part 2
DATV Express Project:
Digital ATV Transmitter
DATV Transmitter for the ISS

Visa, M/C, AMEX PayPal via
Internet: www.atvquarterly.com

email: wa6svt@atvquarterly.com

The DATV Data Repeater in New Zealand

By Grant ZL1WTT

Background

Last century ATV was dominated by analogue forms of transmission, whereby we were using electronic hardware to create a moving picture. These days there are far more opportunities to explore with software and how that information is being sent. Back in the 1980s we were rechanneling radio telephones to operate on VHF 6 and 2m bands. Today we are doing the same with WiFi equipment on the microwave bands.

Introduction

In the last two years new technology has become available that has reformed how we use ATV. This is why I have been spending so much time working on DVB (Digital Video Broadcast) transport

streams. Most Amateurs seem to be preoccupied with just the modulator side of DVB the hardware layer (layer 1). This is just one link in the data chain, whereby I have been more interested in the data layer (layer 2). When you take a look at Ham Radio from this standpoint you gain a whole new perspective on the way to move ahead with this technology.

The data layer

We are now moving into a radio world where by moving large amounts data becomes very important and therefore has a monetary value. This is where we need to have access to usable Microwave spectrum with a large amount of bandwidth to experiment with.

As part of this thinking we need to move away from just playing around with SSB that is only a few kHz wide to maximize the use of bands.

Robert ZL1FLY has been doing some very interesting work with Mesh networks on 13cm. This is a new form of packet radio, instead of sending bits per second we can now send a few megabits per second. This is about the only mode we can use on 2.4GHz these days.

The Ubiquiti products are becoming very common these days and are somewhat inexpensive to buy. They will operate out of the box on three Amateur bands 13, 9 and 5cm.

On the right is picture is of a 3.4GHz Ubiquiti Rocket M3, this is what I am currently testing on the 9cm band. Experiments with the 5.8GHz Ubiquiti Rocket M5 within a 20MHz channel, I got data throughputs up to 35Mb/s more than enough throughput for a whole DVB multiplex.

Below is a layout of my home DATV setup. I have moved away from fixed hardware configurations and gone with IP switching. By working at this IP layer this has provided me with a lot of flexibility that you would not get in any hardware. Any configuration change can be done at the click of a mouse or can be automated.

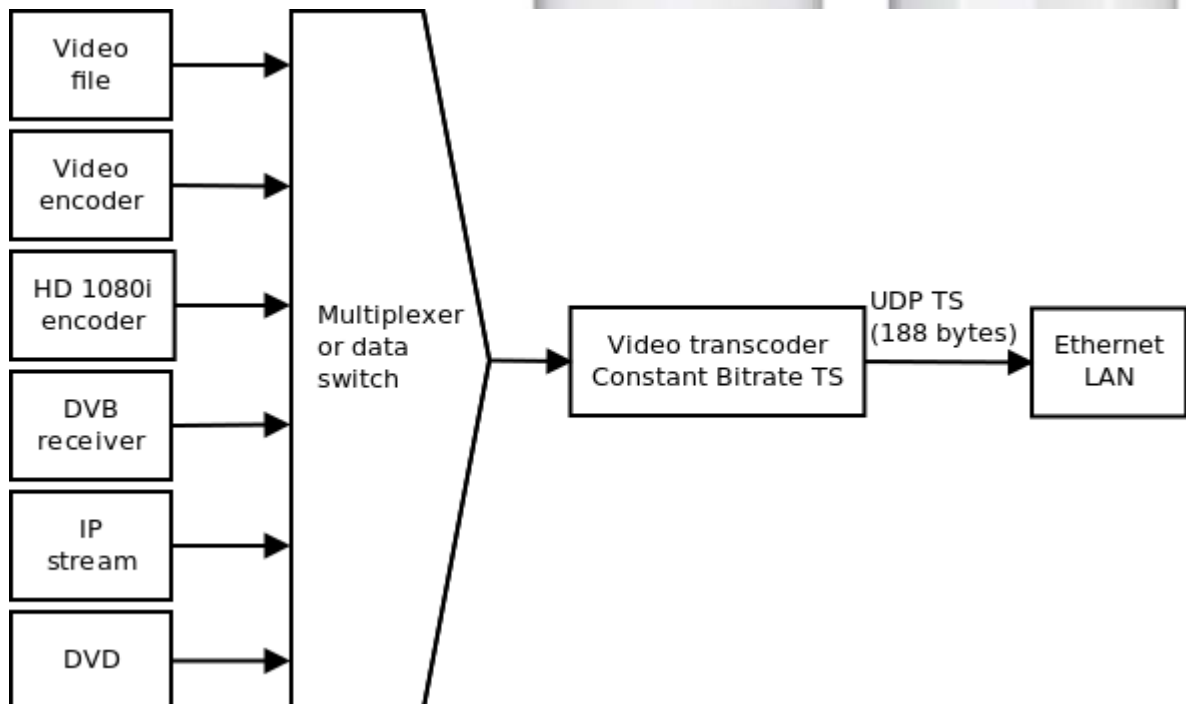

The data pipe. There is no longer a need for analogue video, this has been taken out of the loop. For example playing a media file, the only loss you would get is in the transcoder stage. This is set by the video bit rate, type of encoder used and quality of this encoder. Or maybe you could just run the HD PVR by set it's H264 encoding to constant bite rate and bypass the transcoder stage all together.

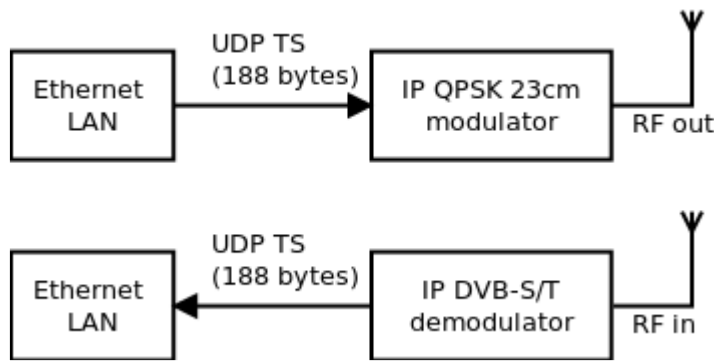

As part of this network you also require an UDP TS(User Datagram Protocol) (Transport Stream) IP based QPSK modulator to send digital video or data to. I have gone with cable TV modulators that cost only a few hundred dollars these days.

I'm also working on software to run on a Raspberry Pi that uses the Ethernet in,

with the on board output ports to drive a QPSK modulator.

The future of this technology is going to be at this IP layer and whereby Amateur Radio is no more than just a part of a physical layer. The cost of IP to ASI media converters are dropping down in value making them a lot easier to obtain. I'm now also starting to see QPSK

modulators coming out on the market with an IP interface, removing the need for an IP to ASI converter.

As for the demodulator, this is nothing more than a Hauppauge Nova-S plus PCI card, you could just as easily use a HVR-3000 that does DVB-T and DVB-S.



Set top boxes can also be used with DATV such as Sunray 800HD 3 in 1 with its triple tuner DVB/S/S2/C/T.

By replacing its Linux operating system with an open version for this box it will come alive. It can be set up as a media center PVR with the addition of a hard drive, and the best of all you can IP stream anything that is being received from the digital tuner.

This set top box has, Mpeg2, H264, AC3, AAC+ decoders built in, in its hardware chip set. With HDMI video output it can view a wide range of picture formats up to HD 1080i.

Band layouts

In New Zealand the 23cm band out of all bands above 1GHz has been the most useful for experimentation.

Low enough to do measurements with and easy to build test gear. High enough to get good aerial gain with low coaxial loss.

Out all these years of experimenting with all types of wide band modulation systems, the important thing is a workable band plan, and that provides room to test these new modulation systems

23cm band layout

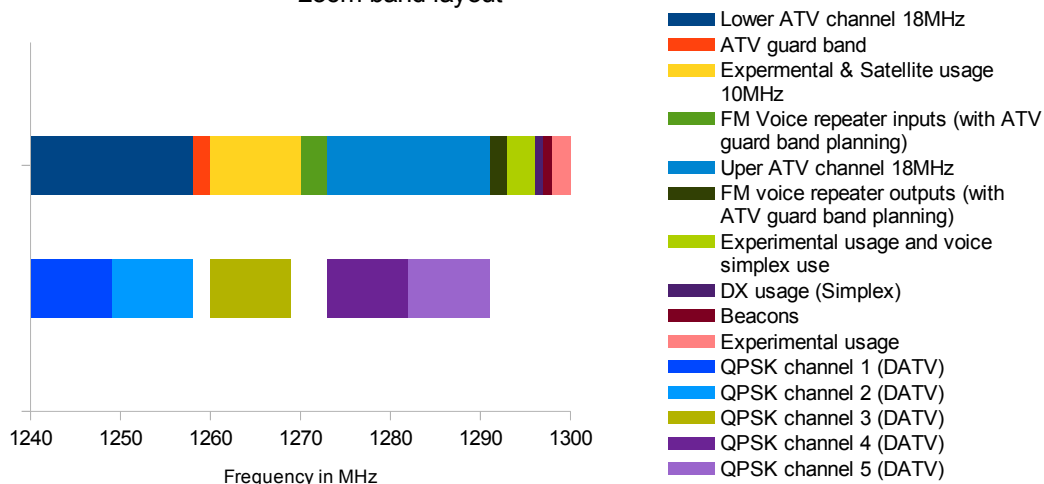

Another good thing is to plan around wide band users by grouping these modes together. This will provide space for filters to pass and reject nearby narrow band users.

Here in Auckland we have gone with horizontal polarization for ATV

transmissions and narrow band users are vertical. This has the advantage of giving us another 20dB of isolation from other users within the same band.

The 13cm band has become a real problem here in Auckland with other users. It's not usable for standard FM TV

and QPSK modulation between 2.4 to 2.45GHz. So the only way we can use this spectrum to go with spread spectrum modulation techniques, such as WiFi equipment. The most useful part of this band, 2.3 to 2.396GHz, has been removed, this has had a big impact on my experimentations

13cm band layout with WiFi channels

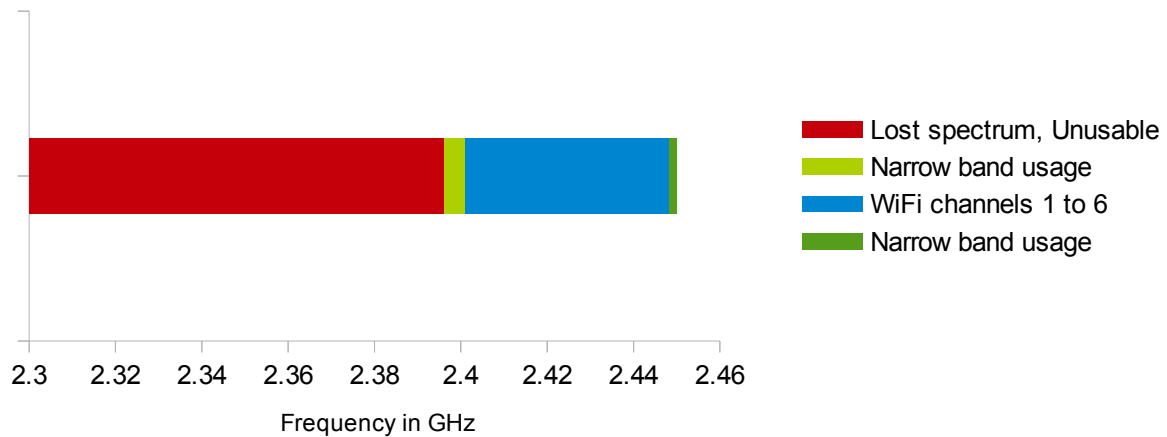

The 9cm band is now where I'm looking at setting up 30Mb/s data links. By re-flashing the operating software you can shift WiFi equipment down from 3.4 to

3.7GHz to just below 3.4GHz to fit within this band layout. It would be a lot easier if I just programmed up this equipment within the top end of this band, but again that

has been affected by the removal of 3.41 to 3.5GHz.

9cm band layout with data channels

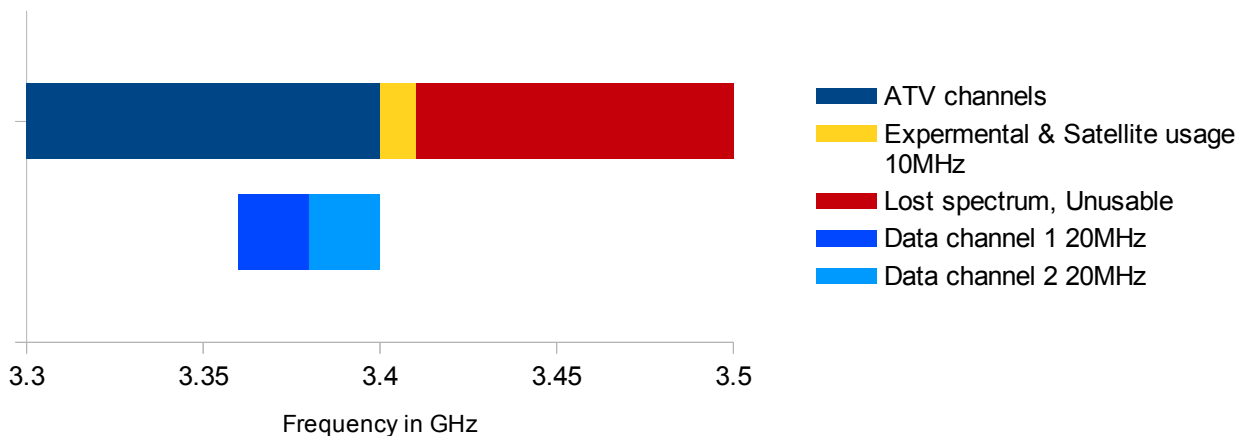

As you can see, it has become a race against time to use these microwave bands before we end up losing this part of the spectrum. There are still new modes

that can be tested and a lot of unknowns with propagation. This is where we need to come up with common band plans worldwide, this is to encourage manufacturers

to make equipment available for these Amateur bands

DATV repeater configurations

There are two types of DATV repeater layouts. One is standard QPSK receiver connected to a DVB modulator this could be COFDM (DVB-T/T2) or QPSK/8PSK (DVB-S/S2).

The other is IP based using 9 or 5cm bands, this can be both input and output within the same data channel. This can be controlled by remotely setting the IP to ASI media converter for data sending,

receiving or both. Another advantage with configuration is inter-repeater linking by sending or receiving DVB transport streams via the Internet.

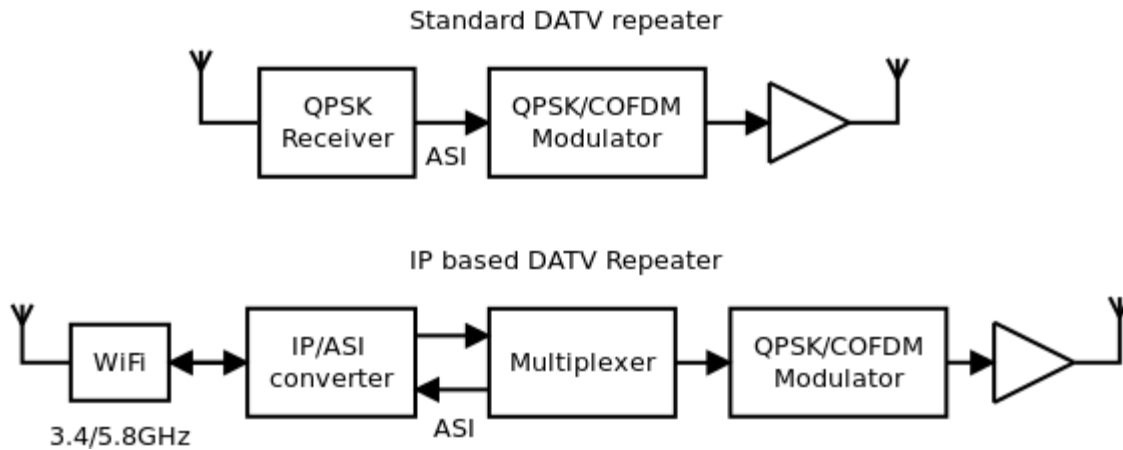

Requirements for a DATV data repeater

Must be:

- 1/ Hardware based
- 2/ Upgradeable
- 3/ Compatible with IP interfacing and streaming
- 4/ Access controlled
- 5/ Able to support both analogue and digital inputs

Equipment

Like my home set up, a repeater needs to operate at this data layer and be able to integrate with a Mesh data network.

This is where the high speed data pipe comes into play using the Ubiquiti Rocket M3 as the 3.4GHz IP port.

The Auckland repeater hardware is a combination of home built and cable TV models.

Technology has moved ahead at a fast pace these days, as little as 10 years ago there were only SR-systems boards available.

Nowadays with changing requirements for IP linking between repeaters and wide band data transmissions a modern day DATV repeater needs to do so much more.

With IP controlled configuration, we can remotely log in to the repeater and change the operating parameters like:

- 1/ Data repeater mode without video been sent
- 2/ Data and video information to be sent
- 3/ Video channels only
- 4/ Video encoder bit rates
- 5/ QPSK receiver setting such as frequency and symbol rate
- 6/ Number of channels within the multiplex or multiplex bypass mode
- 7/ Modulator bit rate
- 8/ IP streaming on/off
- 9/ Analogue video switching via the Kramer switch

ZL1BQ DATV repeater:

This is a hybrid configuration design to work with both analogue FM TV as well as digital inputs.

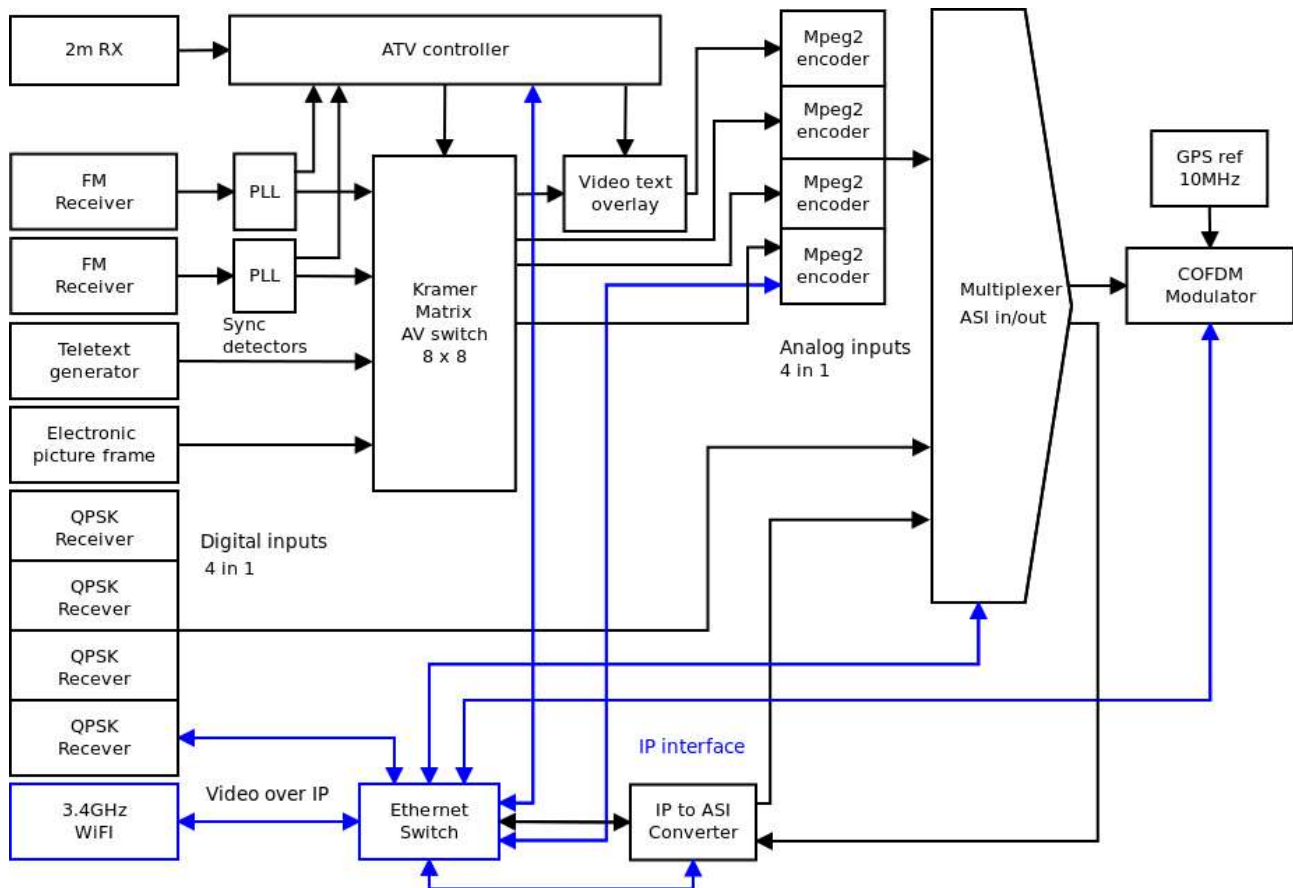

The International Space Station DATV. Part 2

By : Gaston Bertels, ON4WF. ARISS-Europe chairman

Ground Station Components

1. Parabolic Dish with AZ-El Pointing

The dish shall be mounted for azimuth and elevation pointing and moved by precision motors. with a total system pointing accuracy of 2° or less (including motor precision, antenna alignment, and pointing control software).

The elevation movement shall cover 180 degrees (flip mode capability).

The azimuth movement shall cover 360 degrees or more.
A possible alternative to the flip mode for the elevation movement is the capability

of azimuth movement up to 540 degrees to allow for reception of ISS passes over north.

Azimuth angular speed greater than 5°/sec allows for reception of ISS passes up to 90° elevation. Less angular speed will allow reception of passes with lower elevation.

The AZ-EL motors for the main European ground stations are made by Prosistel (<http://www.prosistel.it>).

The driver is WISP DDE by CX6DD (<http://www.mederoscnc.com/CX6DD/wispdde/wispdde.htm>) modified by AMSAT Italia in order to interface Prosistel rotors in the Azimuth extended-range mode.

This modified version of WISP DDE also allows automatic sweeping of the antenna around the Sun direction, in order both to check correct Az/EI alignment and to measure G/T of receiving system.

2. Tracking Software

A number of shareware, freeware, cardware and commercial tracking softwares are available on the web.

Selection of the software shall take care of the capability to drive the AZ-EL motors, flip mode included.

The tracking software used for the on-going tests is Orbitron (<http://www.stoff.pl/>).

3. LHCP dish feed

ARISS antennas on Columbus are right circularly polarised.

The dish feed can be a patch type or a helix type, positioned in the focus of the parabola.

HamDesign (<http://www.rfhamdesign.com>)

Hence, for single reflector antennas, the feed shall be left hand circularly polarised, since each dish reflection reverses the polarisation.

The dish feed used for ARISS-Europe ground stations is a product of RF

Type: LH-13XL , 2.1 - 2.7GHz , Connector N-Female 50 ohm

4. LNB

ARISS-Europe ground stations are equipped with an LNB downconverter produced by Kuhne Electronic.

The LNB is designed for mast mounting near the parabola.

Two options are suitable :

Option 1 :

KU LNC 25 TM (centered 2450 MHz)

Frequency range : 2350 – 2550 MHz

IF : 1433.5 – 1633.5 MHz

Amplification : 40 dB

<http://www.kuhne-electronic.de/en/products/down-converters/ku-lnc-25-tm.html>

Option 2 :

KU LNC 23 TM (centered 2385 MHz) – specific DATV

Frequency range: 2320 – 2450 MHz

IF : 1404 – 1534 MHz

Amplification : 40 dB

<http://www.kuhne-electronic.de/en/products/down-converters/mku-lnc-23-tm.html>

The KU LNC 23 TM has a notch filter on 1.3 GHz for duplex operation : 1.3 GHz (transmit) and 2.3 GHz (receive). This could be useful from the perspective of a planned cross band voice transponder on Columbus.

5. DVB-S Satellite Receiver

A suitable DVB-S satellite receiver PCI tuner card is produced by Techno Trend:

http://www.technotrend.eu/2920/TT-budget_S2-1600.html

The Techno Trend card fits in a PCI computer slot and supports HD TV (MPEG2 and MPEG4/ H.264) :

- Computer OS : Windows XP, Vista, Windows 7, Windows 8
- CPU for SDTV: at least 800 MHz
- CPU for HDTV: at least P4 3,4 GHz or comparable AMD Athlon (Dual Core recommended) - not needed for Ham TV
- 512MB main storage (1024MB recommended) at least 1GB free hard disc storage
- Graphics card with at least 64MB and DirectX 9 support
- Sound card with DirectX 9 support

Besides the TT-budget S2-1600 card, TechnoTrend produces the TT-S2-3200 card, also suitable. In addition to the PCI

card ground station solution described, it is understood that some specific DVB-S "set top" boxes are able to operate

correctly at the symbol rates that will be used by the Ham TV system.

6. Measurement and Display Software

Jean Pierre Courjaud F6DZP has developed a free software utility providing radio amateurs and DVB technicians with a tool that allows Digital ATV (DVB-S) to

be measured precisely. With the above mentioned setup, Ham Video from Columbus can be received, decoded and

viewed on a computer screen. Audio is also available

Please see:

<http://www.vivadatv.org/page.php?p=tutioune-en>

This software comes in two versions:

- Tutioune V2.0 for use with the TT S2-3200 card: <http://www.vivadatv.org/viewtopic.php?f=60&t=205>
- Tutioune 1600 V0.1 for use with the TT S2-1600 card: <http://www.vivadatv.org/viewtopic.php?f=60&t=214>

7. Noise Power Measurement for antenna alignment.

As suggested by Piero Tognolatti I0KPT and with his collaboration, Jean Pierre F6DZP developed special software for Noise Power Measurement. With this software, a TT-S2-3200 or a TT-S2-1600 PCI card can be used for Dish alignment by measuring the Sun noise on S-band. See:

<http://www.vivadatv.org/viewtopic.php?f=67&t=212>

8. Streaming video on the Internet

For H264 encoding and streaming video on the Internet, several software solutions exist:

- Adobe Flash Media Live Encoder (FMLE) – free – Win XP, Win7, Win8
- FFsplit – free – Win7, Win8
- Open Broadcaster (OBS) – free – Win7n Win8
- Xsplit – only basic functions are free – Win XP, Win7, Win8

For H264 encoding and streaming, a good Dual Core or a Quad Core CPU is needed. Sending the video stream, produced by the DVB-S receiving software, to the Internet encoder/streamer software (FMLE, OBS...) needs additional software such as Vcam.

Main Specification

Parabolic dish

Polarisation : RHCP
Gain about 26 dB

AZ-EL rotor

accuracy : +/- 2 degrees (1.2 m dish)
slew rate : 5° per second
range : 0-180 elevation & 0-360 azimuth

LNB (Low Noise Block downconverter)

input frequency : S-band
output frequency : L-band
gain : at least 40 dB
frequency stability : +/- 20 kHz
noise figure : about 0.7 dB

Tracking software

allowing flip mode

DVB-S receiver

TT S2-3200 card
Or
TT S2-1600 card

For further information see: <http://amsat-uk.org/>

www.agaf.de



T V AMATEUR



Nr. 169
45. Jahrgang

2. Quartal 2013
EUR 6,- DFR 10,- US\$ 2,-

ATV SATV SSTV SAT-TV RTTY FAX AMTOR FACTOR DATV



Zeitschrift für Bild- und Schriftübertragungsverfahren

Amateurfunk - Fernsehen



- **ATV-AG München auf der HAMRADIO 2013**
- **DVB-T auf 70 cm mit 2 MHz Bandbreite**
- **Prototyp des GMSK/QPSK-Monoboards**
- **Vom Print zum (portablen) Display**
- **ATV-Treffen auf Dahses Erbhof**

HDTV-NEWS

BATC out and about



27 – 28 September - National Hamfest, Lincoln.
BATC will be on the: Lincoln Repeater Group stand.
See: www.nationalhamfest.org.uk



11 – 13 October - RSGB Convention
See: www.rsgb.org
BATC will have a stand here.



26 – 27 October – BATC Convention CAT13 – Finningley, Doncaster
See: www.batc.org.uk



10 November – West London Rally – Kempton Park, Surrey
See: www.radiofairs.co.uk

We hope to meet you at one of the above.

If you would like BATC support for your event please contact the membership secretary.