

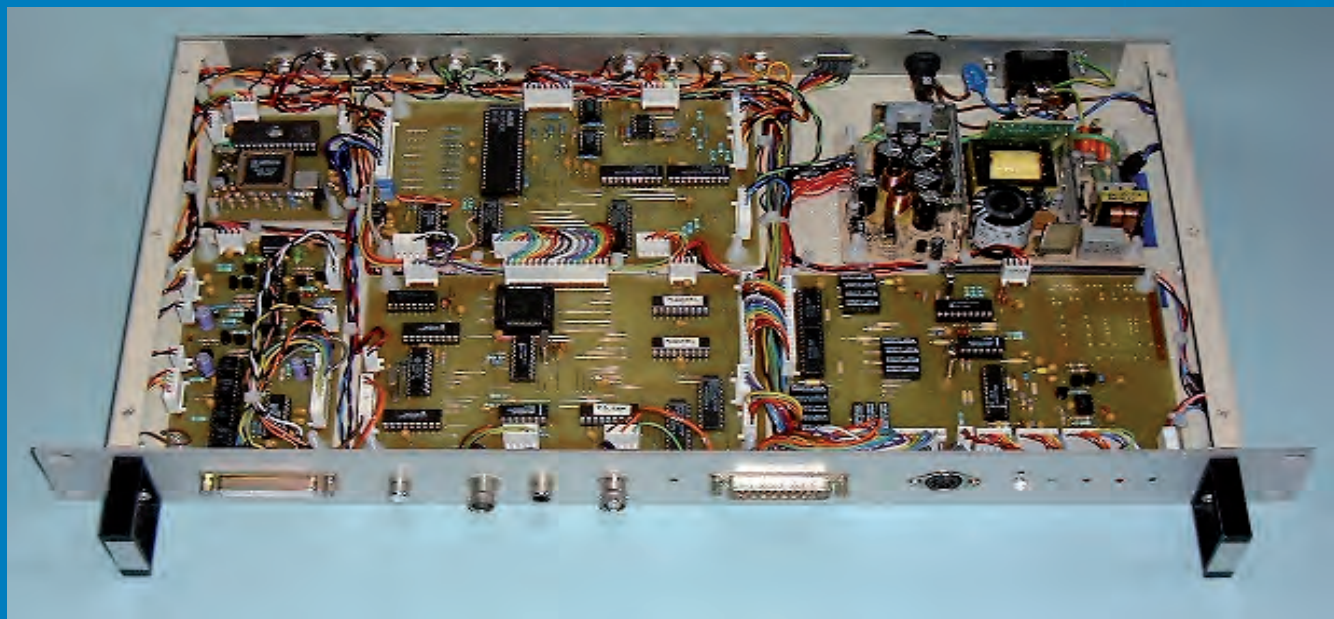

CQ-TV 217



Repeater Project - page 14



2.4GHz antenna - page 12

CVBS to YC Splitter - page 26

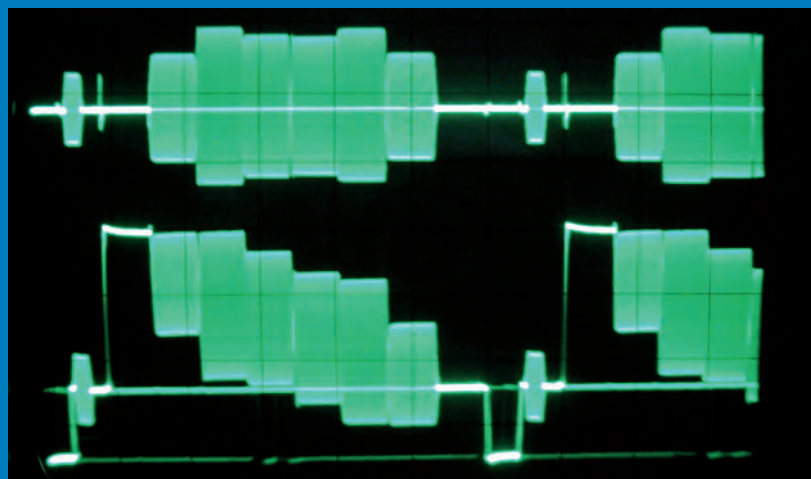



Caption competition

Can you think of a caption for the above picture? If you can, then send your entry to chariman@batc.org.uk. The winner will receive a Black Box caption generator.

PIC On Screen Display Project Board

The Versatile, Programmable On Screen Display System



The BlackBoxCamera™ Company Ltd. sponsors the CQ-TV caption competition. The winner will receive a keyboard text overlay unit.



Free demo code

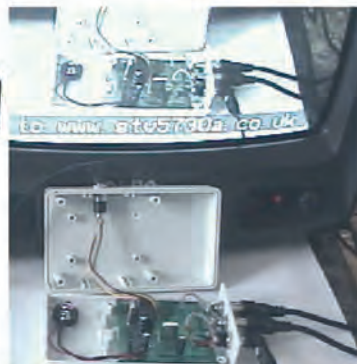

- PIC 16F628 microcontroller
- 28 by 11 character OSD
- Fully programmable
- Demo software available
- I/O lines for sensor interface
- RS232 serial interface
- PAL or NTSC compatible
- Enclosure option available

Enquires sales@STV5730A.co.uk to www.stv5730a.co.uk

Visit www.STV5730A.co.uk

Contents

Adding 3cm to the GB3BH repeater.....	38
Advertising Rates.....	4
ATV REPEATER CONTEST RULES	35
ATV Repeater Project	14
Autocycler For The Teletext Video Generator	32
A CVBS to YC Splitter.....	26
A Question of Gamma	23
Book Review.....	33
Caption competition.....	2
Circuit Notebook No.92.....	11
Committee Contacts.....	4
Contents	3
DATV over IP	7
Deadlines.....	4
Embedded Audio.....	28
Gennum calls "last orders" on certain analog parts	31
IARU REGION 1 INTERIM MEETING.....	5
Loose Ends.....	6
Secretary's Transmission	6
September International Contest Results.....	34
"Turning Back the Pages".....	24
Walkabout Antenna for 2.4GHz	12

Copyright © by the BATC and contributors.

Legal Niceties (the small print)

E&OE. Whilst every care is taken in the production of this publication, the editor accepts no legal responsibility for the advice, data and opinions expressed. The BATC neither endorses nor is it responsible for the content of advertisements or the activities of those advertisers. No guarantee of accuracy is implied or given for the material herein. The BATC expressly disclaims all liability to any person in respect of anything and in respect of the consequences of anything done or omitted to be done wholly or partly in reliance upon the whole or any part of this magazine.

As the regulations for the operation of radio frequency equipment vary in different countries, readers are advised to check that building or operating any piece of equipment described in CQ-TV will not contravene the rules that apply in their own country. The contents of this publication are covered by international copyright and must not be reproduced without permission, although an exception is made for not-for-profit publications (only) wishing to reprint short extracts or single articles and then only if acknowledgment is given to CQ-TV.

Apart from any fair dealing for the purposes of published review, private study or research permitted under applicable copyright legislation, no part of this publication may be reproduced, stored in a retrieval system or transmitted in any form or by any means, electronic, mechanical, photocopy, recording or otherwise, without the prior permission of the publisher. All copyrights and trademarks mentioned in this publication are acknowledged and no infringement of the intellectual copyright of others is intended. Printed in Great Britain. ISSN 1466-6790

Notice to Contributors

Authors are alone responsible for the content of their articles, including factual and legal accuracy, and opinions expressed by them may not reflect the editorial stance of the publication. Material submitted to CQ-TV should not infringe the copyright of other writers or bodies. Articles remain the copyright of their authors and following publication in CQ-TV, they may also appear on the BATC's web site and CD-ROMs, also in other not-for-profit amateur publications. Contributions are accepted for publication on this basis alone.

Printed by Hastings Printing Company Ltd., Drury Lane, St Leonards on Sea, TN38 9BJ, England. Telephone: 01424 720 477.

Committee Contacts

President: Peter Blakeborough G3PYB

E-mail: president@batc.org.uk

Chairman: Trevor Brown, G8CJS

Club affairs, Videotape library, and Technical queries, especially relating to handbook projects. 14 Stairfoot Close, Adel, Leeds, LS16 8JR. Tel: 01132 670115

E-mail: chairman@batc.org.uk

General Secretary: Graham Hankins, G8EMX

General club correspondence and business. Library queries relating to the borrowing or donation of written material. **Graham Hankins G8EMX**, 17 Cottesbrook Road, Acocks Green, Birmingham, B27 6LE. Tel: 0121 706 7384

Email secretary@batc.org.uk

Hon. Treasurer: Brian Summers, G8GQS

Enquiries regarding club finances, Donations, and constitutional enquiries. 9 Prior Croft Close, Camberley, Surrey, GU15 1DE. Tel: 01276 677879, Mobile 077 4029 1191

Email: treasurer@batc.org.uk

Membership:

Anything to do with membership, including new applications, queries about new and existing membership, non-receipt of CQ-TV, subscriptions, membership records etc. Pat Hellen, The Villa, Plas Panteidal, Aberdyfi, Gwynedd, LL35 0RF, UK. Telephone 01654 767702

E-mail: memsec@batc.org.uk

Club Liaison:

And anything of a political nature, co-ordination of ATV Repeater licences. Graham Shirville, G3VZV, The Hill Farm, Potsgrove, Milton Keynes, Bucks., MK17 9HF. Tel: 01525 290343.

E-mail g3vzv@amsat.org

Contests:

Dave Crump G8GKQ.

Email: contests@batc.org.uk

Anything for publication in CQ-TV:

Articles, Review items, Letters to the editor, and other material except as below. By Post to Brian Kelly. The Villa, Plas Panteidal, Aberdyfi, LL35 0RF, UK

Email: editor@cq-tv.com.

Photographs for the CQ-TV covers: Please send any photographs by post and electronic images by email, to the editor at the above address.

CQ-TV Advertising:

Trevor Brown, 14 Stairfoot Close, Adel, Leeds, LS16 8JR. Tel: 01132 670115

Email: adman@batc.org.uk

Members adverts for inclusion in CQ-TV should be sent directly to the editor and the above address, either by post or e-mail.

CQ-TV and BATC web Masters

Anything to do with the CQ-TV web site

Email: webmaster@cq-tv.com

or for the BATCs web site.

E-mail: webmaster@batc.org.uk

Exhibitions:

Graham Hankins G8EMX,

17 Cottesbrook Road, Acocks Green, Birmingham, B27 6LE. Tel: 0121 706 7384

Email: exhibitions@batc.org.uk

Publications:

Handbooks, Back copies CQ-TV, and anything related to the supply of BATC publications. **Paul Marshall**, Fern House, Church Road, Harby, Notts., NG23 7ED

E-mail: publications@batc.org.uk

Advertising Rates

If you would like to advertise in CQ-TV, then please contact our advertising manager, Trevor Brown, 14 Stairfoot Close, Adel, Leeds, LS16 8JR, England. Telephone: +44 (0) 1132 670115. Email: adman@cq-tv.com

Size	Mono	Colour
Quarter page	£50	£75
Half page	£100	£150
Full page	£150	£200

Deadlines

CQ-TV is published quarterly in February, May, August and November each year. The deadlines for each issue are as follows: -

February	-	please submit by	December	31st
May	-	please submit by	March	31st
August	-	please submit by	June	30th
November	-	please submit by	September	30th

Please send your contributions in as soon as you can prior to this date. Don't wait for the deadline if you have something to publish as the longer we have your article, the easier it is for us to prepare the page layouts. If you have pictures that you want including in your article, please send them, in the highest possible quality, as separate files. Pictures already embedded in a page are difficult to extract at high quality but if you want to demonstrate your preferred layout, a sample of your finished work with pictures in place is welcomed. Please note the implications of submitting an article which are detailed on the contents page.

IARU REGION 1 INTERIM MEETING

The IARU Region 1 meetings take place every three years and, in between, “interim” meetings are held – usually in Vienna. At these meetings, papers, from various National Societies, are discussed but no decisions can be made until the subsequent Meeting proper. There is an interim meeting taking place late in February 2007 and in this case the next full meeting will take place in Croatia in November 2008.

One of the papers that will be discussed in C5, the VHF/UHF and Microwave committee, is printed in full below as it has been somewhat misunderstood by a number of ATV amateurs around Europe!

+++++

Document B15

Subject 23cms Bandplan

Societv RSGB

Contact Murray Niman, G6JYB

Status Proposal

Background

Increasing use by current and future Primary Users in the 23cms band necessitates prudent planning of what might become a much smaller effective Amateur allocation. This also adds to the demand for spectrally efficient ATV.

Considering that:

.Safety-of Life radio navigation and other Primary User applications/developments make 23cms amateur allocations/clearances vulnerable and increasingly challenging.

.The Galileo system is progressing and may cause radars to move. For example Galileo has effectively been given priority by CEPT over Wind Profiler radars.

Analogue A TV requires considerable bandwidths that can make it difficult to gain clearance in this band in particular, or uses wideband receivers that may be vulnerable to Primary User interference. In contrast DA TV developments such as QPSK can be robust and their lower bandwidth (typically 4MHz max) facilitates regulatory clearances and alternative bandplanning.

.There is no harmonised “reserve” frequency for narrowband working and beacons, should 1296MHz become unavailable.

.Traditional packet/data/fax usage is declining in 23cms.

Proposals:

1. That developments in Digital ATV , using no more than 4MHz bandwidth, be encouraged with a long term view to facilitating ATV Digital Switchover in this band (and 70cms).

2. That priority is given to agreeing harmonised “reserve” frequency(s) for 1296MHz narrowband.

3. That discussion on a potential alternative 10MHz wide band plan is undertaken, possibly in the 1240-1250MHz area (outside of the Galileo band), or the 1260/70 sub-band and/or the 1290-1300 band.

4. That the VHF Handbook 23cm bandplan footnote on beacon co-ordination be considered outdated and removed.

+++++

So what is actually meant by this paper?

Put simply, Murray Niman, G6JYB, who is the new RSGB Microwave Manager and who attended the BATC Meeting in Cambridgeshire last summer, is proposing a possible alternative bandplan that might be necessary if our allocation were to be dramatically reduced.

He is suggesting that it may be possible that the implementation of the Galileo satellite navigation system sometime in the future could lead to a dramatic reduction to our access to some of the band below 1300MHz. The paper assumes that only 1240-1250MHz might be available for all amateur users. (NB the paper ignores reference to the 1300-1325MHz part of the band, as this is a UK only allocation)

If this dramatic change were to occur then how could all the present 23cms users be accommodated in 10MHz? Well, sadly, FMATV could not be accommodated there and therefore DATV could be our only option. BATC is of course not in favour of any such change and would strongly resist such restrictions in the UK.

So although the paper has been misrepresented as an anti-FMATV RSGB paper, it is really not. Rather it is a background paper to promote consideration and discussion of a “what if” scenario.

We will report back from the meeting on how the discussions went!

Report by Graham Shirville

Secretary's Transmission

Hi and P5 from me, Graham Hankins G8EMX, a bit further up the committee list to fill the Secretary position relinquished by Paul Marshall after many many years service. Paul's main comment was to be prepared for phone calls at 3am! Haven't had any yet, at any time – and I do have an answering machine! But have had loads (and loads and loads) of 'spam' Emails redirected from secretary@batc.org.uk – one of these WAS an actual request to the secretary □

I have deliberately titled this piece 'Transmission' because actual practical ATV is where I firmly 'come from' within the BATC so I suppose I should really actually do some ATV operating sometime this year! All necessary hardware is here, so it really is just a matter of blowing the dust off - me that

is, not the gear – then stop writing and get doing. Ah, words are easy.....

But seriously folks (Hawkeye Pearce, 'MASH' – yes I DO watch too much TV and with Sky available in my temporary accommodation – don't even TRY to count the channels – this could become addictive) in his Foreword to the RSGB Yearbook 2007, General Manager Peter Kirby G0TWW states: "The hobby continues to grow, with around 2,000 new entrants a year through the Foundation Licence scheme. And..... since the three-tier licence scheme came into being in 2004, nearly 1000 M3 entrants have now reached the Advanced level". So, it seems that Amateur Radio is NOT dead, perhaps not even sick ("I told you I was ill" – Spike Milligan's self-written epitaph) and it would obviously be great for our hobby if some, oh go on then,

many of these new Radio Amateurs discovered Amateur Television. Well, there are loads of Radio Clubs listed in the Yearbook – perhaps I could write to the Regional Managers – I now know who you all are – introducing ATV to them and the clubs in their Regions. Hmmm, seems like a Cunning Plan (Baldrick – 'Black Adder')

Enough already (Jackie Mason); 'Frasier' is on Paramount Comedy and I think Brian Kelly's workload is piled high enough already.

73 and P5

Graham Hankins G8EMX – postal address and phone number subject to changes so until my situation has stabilised, g8emx@tiscali.co.uk.

Loose Ends



Entries for last issues caption competition were:

[sings] 'I could have danced all night'
- Giles Read

'Look - There is a whole World out there'
- Eric Dean

"... and on my extreme right Mrs. Trellis from North Wales."
(If only someone had remembered the 16 x 9 camera)
- John Van Dyken

'On the other hand.....'
- John Lawrence.

Personally, I would have gone for:

'If I sprinkle this stardust on Brian Kelly's head perhaps he will change into an Editor'

But as judge, I don't think I'm allowed to enter. Besides, I won one (anyone know where it is?) a few issues back. I hasten to add that someone else chose the winner on that occasion!

I think John Van Dyken has the wittiest comment this time so I announce him as winner. Well done John, a caption generator of the electronic variety will be on its way to you soon.

The Editors Seat.

(No comments on it becoming large and rounded through lack of exercise please!!!)

I took on the editing roll because of lack of volunteers rather than a passion for magazine production. It's a job I have little spare time to do and I find myself sitting here in the early hours of the

morning with the master copy in front of me far too often.

I think some misunderstanding about the Editor holding a Committee position may have driven potential recruits away. I am on the BATC Committee and I am the Editor but the two are not linked. The Editor does not necessarily have to be on the Committee at all and any member can take on the job without further commitment to the Club.

Of course, anyone wanting the job will be given as much support as possible, including being provided with the software package used to compose the pages (Adobe InDesign CS).

I'm not expecting a stampede of enthusiastic volunteers to charge forward, more likely the reverse, but please consider if you might be able to support the Club by helping out. It is a task ideal for a retired person or someone with time on their hands.

Brian Kelly - Editor.

DATV over IP

by Ian F Bennett G6TVJ

Digital amateur TV has been around for a few years now, for most radio amateurs though this technology is still in its infancy. Thanks to a number of pioneering groups and the innovative products from the German company SR-Systems, many amateurs at least have the opportunity to get involved in DATV.

The author has perfected a number of experimental systems including a DVB-S test transmission via GB3ZZ, a DVB-S 13cm beacon, DVB-T 13cm beacon and a simple 23cm-13cm relay combining the two bands and linking a number of ATV stations in the Bristol area.

The equipment required for DATV is perhaps a stumbling block for stations on a limited budget, the equipment available from SR-systems is still quite expensive, although not so when compared to a complex amateur HF transceiver for example. Radio amateurs are always on the lookout for cheaper solutions, adopting computer technology and in particular wireless-LAN (local area network) technology, could be the answer?

Most DATV systems at the moment adopt technology which adheres to the DVB (European Digital Video Broadcasting) specification. These systems use MPEG2 encoding, the 188 byte transport stream signal interface format and either DVB-S (Satellite modulation) or DVB-T (Terrestrial COFDM modulation). There is another digital signal transport mechanism available and it is the Internet Protocol or IP. IP has been around for many years and is universally adopted in computer networks and the internet. The most common form is TCP-IP, this stands for Transmission Control Protocol-Internet Protocol. TCP-IP is used for transferring files and data from one computer to another, be it in the next room or thousands of miles away.

IP refers to the signal specification or format which defines how computers establish communication and fundamentally how they address each other. Addressing is a fundamental requirement of any computer network,

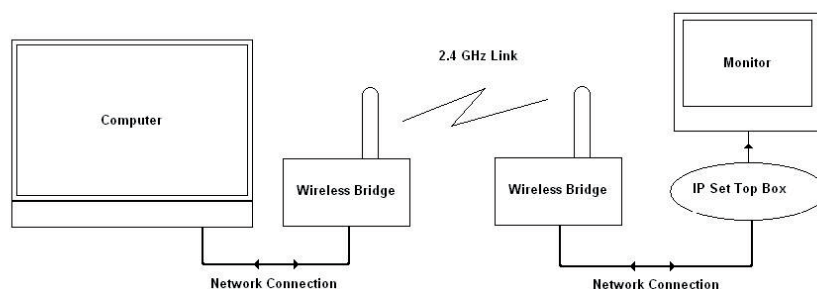

G6TVJ/D DATV-IP Demonstrator

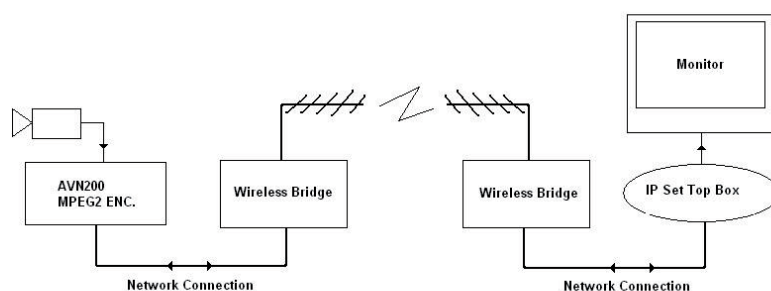

DATV-IP Station Setup

without it data and files would go to every or the wrong computer! The most common electrical interface for IP is Ethernet CAT5 cable. Ethernet has been around for many years and started out life as a coaxial cable format but now has been superseded by CAT5 twisted pair cable.

There are now many wireless (Microwave RF) systems able to carry IP signals, a multi-computer network may be built up with virtually no wires at all. The spectrum for these networks occupies a number of different frequency bands, one of the most common is the 2.4-2.483 GHz band which is adjacent to the 13cm amateur band. It is possible to carry video signals and in particular live video over wired and wireless IP networks, it is this fact that brings opportunities to DATV!

Ethernet CAT5 type computer interfaces send IP traffic in the form of typically 1500 byte frames. These frames are complex packets of data containing not only the required data (payload) but also routing, addressing and error handling information (system overhead). The TCP-IP specification defines this information, there are a number of simpler protocols with reduced error handling capabilities (all networks are subject to errors) and other advanced protocols which operate at higher

levels and correct errors. Protocol is the buzz-word for the language that the equipment uses to handle, manipulate and respond to the data signal.

MPEG2 DVB type signals in many ways are similar to IP signals, the packet size is smaller though, the protocol is simpler and it operates on only a few levels. DVB signals or transport streams rely on a number of regularly transmitted tables to describe how the signal is formatted and identify features in it. Every DVB packet is 188 bytes long and is marked by a unique PID (packet identifier), unlike IP packets there is no routing or addressing information present. Packets are simply transmitted constantly, in the case of a multiple programme transport stream (Freeview BBC1 for example) the decoder examines the tables and with some initial user input decodes the required programme video and audio. A DATV signal radiated from for instance a SR-Systems encoder may contain only one programme. DVB signals operate in one direction only, IP signals operate in both directions and rely on this feature to establish connections between devices across a complex computer network.

The 188 byte DVB video packets are smaller than the typical 1500 byte IP data packets and so it is possible to put



2. Many traditional IP networks may have difficulty in handling the high video traffic bandwidth, this includes the public internet.
3. If a failure occurs, IP networks often take time to re-establish or do not re-establish at all. IP networks are quite fragile.
4. Encoding and Propagation delays can be significant over complex networks.
5. There are many other subtle and complex issues such as packet jitter, arrival times, packet loss, quality of service (QoS) and MPEG PCR (system timing) disruption.

To construct a simple DATV-IP link a number of items of equipment are required which must be configured accordingly. The simplest IP network thankfully may consist of only two items; an originating device and a receiving device connected via a CAT5 cable, this may consist of two laptop PCs for example, for a video link an encoder and decoder are required. To construct a DATV link a wireless system is also required.

Video Encoder.

The simplest way to generate full definition video and stream it to a network is to use the dreaded PC. Software packages are available which will take media such as DVDs and play them out in real time on to the network. To capture and stream live video a special hardware input card may be installed. A freeware package called VLC (www.videolan.org) may be downloaded from the Internet this package takes in a media source and streams it out to the network. VLC is potentially a powerful tool but its functionality is muddled by the need to work across two platforms. VLC will run on both Windows and Linux operating systems but with different facilities. Linux is an operating system invented by computer geeks and like the battle between VHS and Betamax it complicates software and hardware compatibility. VLC is also quite complicated to operate and fully understand its user interface.

What VLC actually does is to “Encapsulate” a MPEG type transport stream. It puts the MPEG 188 byte packets into the larger 1500 byte IP frames. There are many DVB

them into the IP packets and transmit them across a suitably specified and equipped computer network- welcome to video over IP!

It should also be said that it is possible to break up the Ethernet packets in to 188 byte data packets and transmit them over a DVB network!

Video over IP is a fast expanding science, and is the fourth major broadcast delivery mechanism after the digital Satellite, Terrestrial and the Cable systems which are in use today. Video over IP allows live and archived video content to be transported over already installed computer networks, wide area telecom networks and the Internet. There are many forms of Video over IP traffic consisting of small video clips, movie files and web cam pictures, all of these may be sent over IP networks, full definition (and high definition) real time live video however presents a number of challenges, if it is to be transmitted reliably and consistently.

The advantages of Video over IP transmission are-

1. IP traffic is a universal media transmission protocol, any IP network can carry a variety of media. E.g. e-mail, voice and video.
2. Networking equipment is prolific and cheap. (compared to DVB-T modulators which are particularly expensive)
3. Wireless technologies exist which can carry Video over IP on microwave links e.g. DATV link.
4. Multiple destinations may be supported from one source (multicast DATV repeater)

The disadvantages are-

1. The IP protocol is complicated to set up and often difficult to monitor and identify faults.

encapsulator devices on the market, they can be expensive particularly if hardware and not PC based. VLC must be first configured so that it correctly streams the video signal onto the network.

An alternative to a PC is a hardware MPEG encoder with an IP output interface. There are a number of devices on the market that fulfill this function, CCTV surveillance products are the best value, many broadcast streaming devices can be very expensive. A Visionary Solutions AVN200 MPEG2, Exterity or Indigo Visions MPEG4 stand alone encoders may be used as a live DATV encoder, they are first configured via a remote PC connection.

Wireless Transmission

There are many different wireless microwave transmission options, the most appropriate for DATV is a wireless bridge device. Wireless bridges are designed to create a microwave link to join two computer networks together. These devices adopt standards such as 802.11B, 802.11G, WiFi or WiMax. The over the air standards are hidden from the user, when correctly configured, traffic is transparently transferred from one CAT5 port at one end to a CAT5 port at the other, remembering that all wireless technologies are by-directional regardless of whether the traffic carried is or not. There are many wireless devices that may find application with DATV, many devices also incorporate router technologies. IP Routers are devices that interpret the IP addressing information and send packets accordingly in different directions across the network, in big networks they improve the efficiency by managing traffic, bandwidth and sending packets only where they are needed. For a simple DATV point-to-point link a router may create obstacles if not configured properly. Routers may make monitoring network traffic tricky as not all traffic is present at a particular monitoring point or node.

Wireless transmissions operate in defined frequency spectrum, this spectrum is essentially licence free when using the above standards. For amateur use a way could be found to shift the operating frequency of a wireless device. By altering a synthesiser reference crystal the band could be shifted away from the busy ISM spectrum to the relatively quieter amateur spectrum around 2.330 GHz.

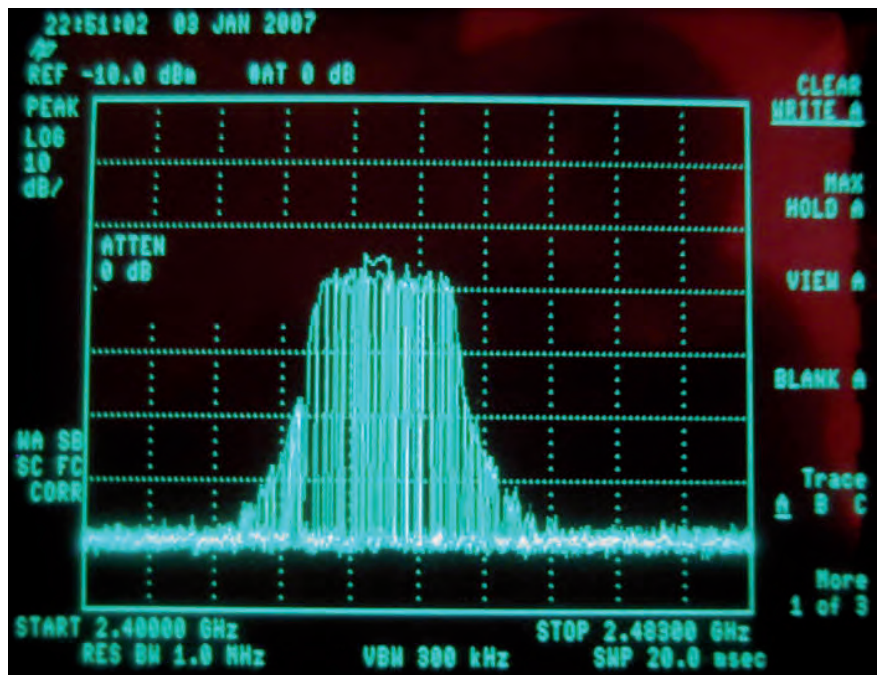

IP transmissions over RF spectrum are difficult to monitor, normal IP traffic has a “bursty” and intermittent nature, a quiet network will appear as a number of pulsating spikes on a spectrum analyser. Video over IP however creates large amounts of traffic that fills more of the spectrum making the presence of the network visible. By using a storage facility on the analyser display a characteristic envelope can be built up revealing the channel and bandwidth occupied by the network.- A useful tool for any so equipped station attempting to identify and receive a DATV-IP transmission!

There are a number of other tools which may assist an amateur when fault finding a network. A common DVB device is a thing called a transport stream analyser, these hardware or computer based products analyse and then disseminate the contents of a video stream.

A useful software tool; www.coolstuff.com TSreader has an IP interface option allowing sophisticated diagnostics to be carried out. Another computer tool is Ethereal, Ethereal is like a TS analyser but for IP traffic, this will capture and display Ethernet packet contents according to type, address etc. When attempting links involving



new technologies the importance of test and measurement tools cannot be over emphasised!

IP Video Decoders

Video over IP traffic may be decoded in many ways. The two most common are PC based "Viewers" (viewers are a bit like internet browsers) and IP set top boxes. VLC provides a PC based viewer that will operate full screen and even does HD. There are issues with these viewers if the bit rate (bandwidth) is too great as they may overwhelm the PC's multimedia processor and intermittently freeze the picture.

A common IP decoder is the set top box (STB). STBs are common domestic devices which traditionally accepted Satellite, Terrestrial or Cable signals, a new breed of the boxes exist now with an Ethernet (IP) input connection. It is now possible to construct an IPTV network in a hotel or residential block, this network distributes live TV over IP instead of the traditional RF coax. IP routers are used to replace RF distribution amps and the rooms or dwellings wired up with CAT5 cable. Back-bones that carry high capacity traffic to these networks may use fibre optic cable infrastructure.

IP Set-Top-Boxes (STBs)

The STBs are small devices sometimes less than 6" square and feature a scart AV output, CAT5 input and infrared remote control. The box contains a MPEG2 decoder (new MPEG4/HD generations are becoming available) and some sort of embedded operating system to handle user interfaces, electronic programme guides and configuration parameters. These boxes are sometimes difficult to get hold of and the manufacturers are not always forthcoming with technical support to individuals.

A common unit the Amino AmiNET 110 may be obtained and used as a DATV-IP decoder. This stand-alone unit produces a full definition composite video output and may be fed from a wireless device via a CAT5 cable. The AmiNET STB is available with a remote IR querty keyboard, this allows setting up of IP addresses and port numbers via a password interface.

IP STBs contain and sometimes expect a certain degree of network derived functionality, creating a simple link can be tricky as the box has to be satisfied before it will display a picture. This is

a bit like the issues experienced with some DVB-T boxes when configuring them for amateur use e.g. setting integer UHF reception frequencies. IP STBs are often sent additional information across the network to help them "Find" the wanted video signal, this is analogous to the DVB table system.

Setting UP a DATV-IP system.

A simple wireless system may be set up using a computer based VLC encoder/streamer, a pair of D-Link wireless bridge units and an Amino STB. This simple two-node network is first constructed by setting IP addresses for the computer (source) and STB (Destination). The D-link units are essentially self-configuring and are placed between the computer and the STB. A correctly functioning network may be proved to be operational by "pinging" the STB from the computer. Pinging is a DOS diagnostic command available in all computers, it simply sends a test packet from a source address to a destination address which is then echoed back, if it doesn't come back, summut is wrong!

VLC must be configured to stream content on to a connected IP network. Firstly the source is selected, in this case a DVD, this will play until it runs out or is manually stopped. DVDs produce MPEG2 encoded material that is put into a transport stream by VLC and then further encapsulated and transmitted. The destination address, protocol type and port number must be set for the system to work. Every device on a network has at least one IP address, within that device ports exist which except packets for different purposes. A common protocol for simple IP streaming is UDP (user datagram protocol). This is a simple one-way protocol that is appropriate for continually issuing traffic such as live video.

The STB is configured to expect traffic from a specific source address and port. The STB will then listen to this address and if traffic appears it will decode and display it. This is a simple scenario, in business systems the STB will rely on more complicated mechanisms to find and identify multiple channels and present them to the user for selection.

Opportunities for DATV-IP

The simple system described here proves the feasibility of a DATV over IP system operating on 2.4 GHz and therefore close to the preferred amateur

microwave frequency spectrum around 2.330 GHz (ATV simplex frequency). The golden rule of any computer network is share it with as few other users as possible! The 2.4 GHz spectrum is crowded, for longer distance contacts alternative spectrum should be sought. Links on 5.8 GHz are available but as they become more popular their traffic capacity will reduce. Amateurs enjoy alternative licensed spectrum so ways could be found to tailor wireless LAN equipment to operate in uncluttered licensed amateur spectrum.

Multicasting

A technique exists in computer networking called multicasting. Normal IP connections are established between only two devices e.g. computer running VLC and a STB. With the help of network routers a mode of operation may be established where multiple recipients receive traffic from one source. A number of hand shaking protocols on the network establish a connection between the subscribing decoders and the router, the router acts as a distribution device and streams the packets to these decoders. A suitably equipped wireless network could send video over IP traffic simultaneously to several DATV stations all subscribing to the same wireless network, A DATV-IP repeater is borne!

Further Info-

www.videolan.org

www.aminocom.com

www.indigovision.com

www.vsicam.com

DATV-IP Technical Specification

Transmitter-

Encoder VLC V8.6 Windows XP OS running on laptop PC (with Network adapter card)

Rate approx 10 MB/s from DVD (HQ)

Standard MPEG2 resolution 576 x 720 pixels

Streaming Protocol UDP (user datagram Protocol)

Receiver-

Amino AmiNET 110 IP STB Pal composite video output.

Circuit Notebook No.92

by John Lawrence GW3JGA

A Simple Peak Video Detector

The original purpose of this circuit was to monitor the amplitude of 625 line monochrome video being fed into an A-D converter. This was part of a 625 line to NBTV Converter (Peter Smith G4JGU, CQ-TV 189, page 15) which allowed the level of the incoming video to be monitored and so avoid over-driving the A-D Converter.

The circuit, which is shown in Fig.1, may be considered in three parts.

DC Restorer

The incoming video is capacitively coupled through C1 to the emitter of TR1. The base is held at approximately +2V by R2 & R3. Negative-going sync pulses cause TR1 to conduct which results in the bottom of the sync pulses being clamped at about +1.4V. R4 is included to stabilise the clamping action.

Level Detector

The level detector is formed by one half of the dual comparator IC1, LM393. The clamped video is fed to pin 3. A DC voltage from RV1, the 'Set Level'

control, is applied to pin 2. Providing that the video signal voltage is lower than that at pin 2, then the output of the comparator is held at 0V.

If the video signal at pin3 exceeds the voltage at pin 2, then the comparator output becomes open circuit and the voltage at pin1 rises to +2.5 volts, determined by R7 & R8.

Monostable

The second half of IC1 is connected to form a monostable (one-shot) having an active period of about 20ms. In the static condition, pin5 is held at +2V by R9 & R10 and the output at pin 7 sits at +5V and is AC coupled to pin 5 by C2. When the input at pin 6 rises to +2.5V (as it will do if the video signal exceeds the threshold set by RV1) then the output of IC1b drops to 0V, thus lighting the LED. This negative change is passed through C2 to R9 & R10, thus maintaining the active condition until C2 is discharged through R7 & R8. The active period is about 20ms which ensures that the LED is on long enough to be visible.

After the active period, the output of IC1b becomes open circuit and C2 is re-charged through R11, R7 & R8.

Setting up.

Assume that the video signal to be monitored is 1V p-p.

1. Disconnect the video input signal. Measure the voltage at TR1 emitter using a high resistance voltmeter. Note the value, typically +1.4V.

2. Measure the voltage at IC1a pin 2 and adjust RV1 so that the voltage is exactly 1V higher than that at TR1 emitter, i.e. +2.4V.

That's it, reconnect the video input, video signals above 1V p-p will be detected and indicated by the flashing LED.

Limitation

As with many things, if it appears to be too good to be true, then it probably is. Due to the speed limitation of the LM393 (about 300ns) the circuit will not respond to a colour sub-carrier if it exceeds the set level. Also, very narrow text/lines may not be detected.

Accepting these limitations, the circuit could possibly replace an oscilloscope for the basic amplitude monitoring of a video signal.

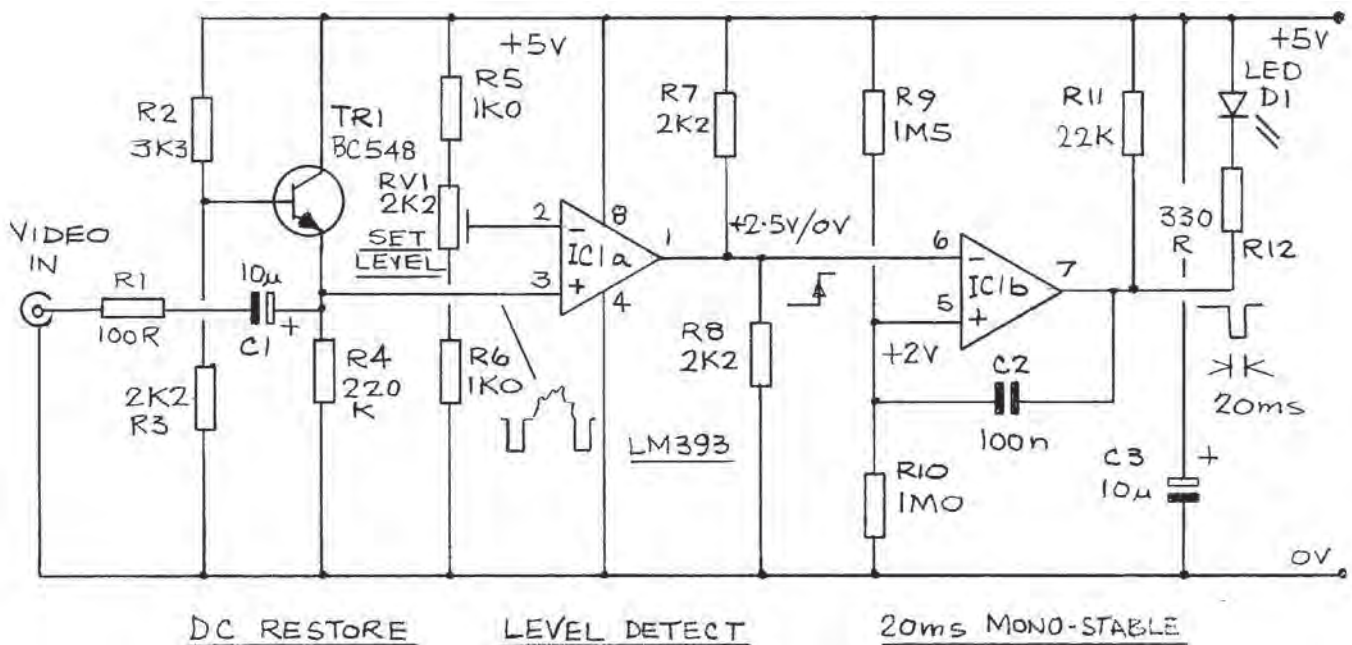

Fig.1. A Simple Peak Video Detector

Walkabout Antenna for 2.4GHz

by Ragnar Jensen.

email: ragnar@jensenjensen.com

How to build a 2.4 GHz ground plane antenna from a piece of coax cable

What you need:

A short piece of 50 ohm coax cable.

A sharp knife.

A pointed tool of some sort.

A ruler.

A soldering iron (optional).

A hot glue gun.

30 minutes of time.



With a pointed tool, carefully unweave the braid...



The raw material: a short piece of 50 ohm coaxial cable.



...until you have something like this.



Cut off approx. 40 mm (1 ½ inches) of the outer insulation.

This exposes the braid that forms the shield of the cable.



Push the braid down to expose the inner insulation.



Form into four equally sized and equally spaced bundles.

These will become the ground plane elements.

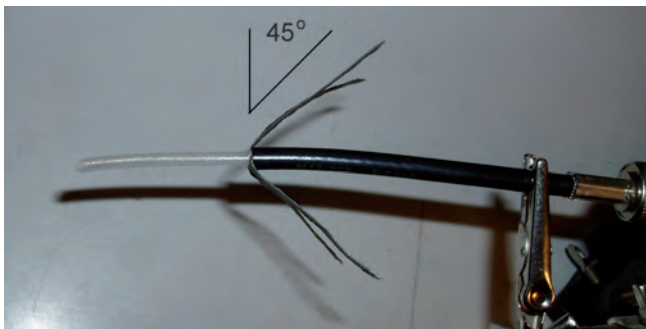
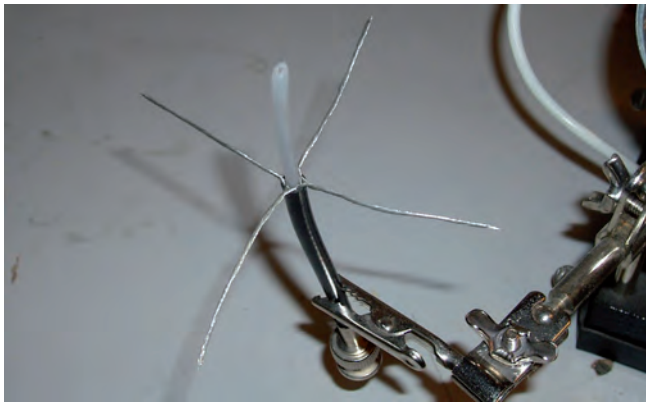

Bend them to a 45° angle. The impedance of the antenna is a function of the angle. A 45° angle will result in an antenna impedance of approx. 50 ohms.

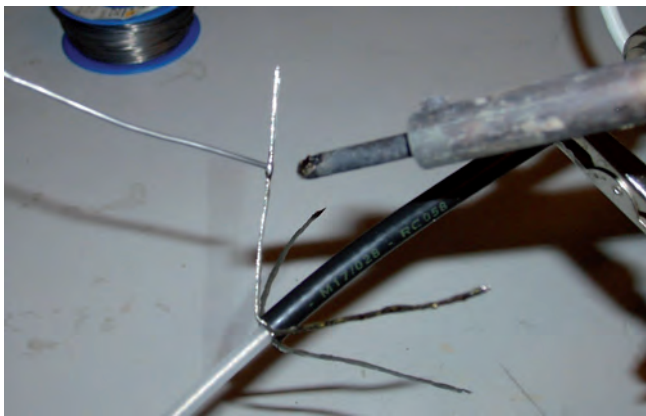

Cover with solder. This step is optional, but it makes the ground plane elements hold their shape better and it keeps them from untwisting.



Finished with the soldering.



A few drops of hot glue...

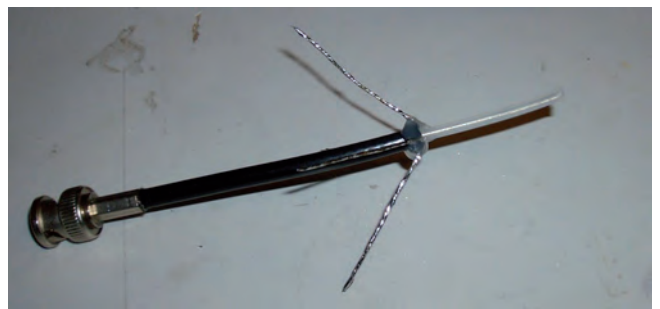

...will help keep the shape.

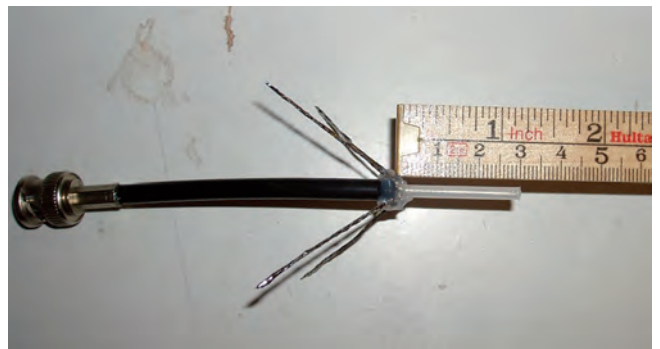

Cut all five elements to a length of 30mm (1- 3/16 inch)



And we are done!

ATV Repeater Project

Part 2

*Design and construction by
Brian Kelly. GW6BWX.*

SYSPROC

This board houses six microcontroller devices. It is the coordinator for all the repeater functions.

The main controller and heart of the system is U2. It is responsible for decoding incoming commands and ensuring the selected port is activated and then written to or read from. It has one 5-bit port (Port A) and one 8-bit port (Port B).

Port A always carries the address of the port selected by incoming command. Bits 0 and 1 are fed 'raw' to some ports where they are decoded internally by the port device. All the bits, including bits 0 and 1 are fed to the PLD U1 which decodes the bit combinations into individual port select lines. These select lines are programmed to the appropriate logic states to enable the port only when it is selected and to disable it at all other times. A 'parking' position at address 1F is provided which disables all port select lines. This address is adopted at all time except during port accesses.

Port B has several roles. The port lines can be programmed to be inputs to the processor or outputs from it. During operation, the direction of the lines is set according to the type of command being requested and by the influence of port devices requesting attention.

Bit 0 is used as an interrupt input. Whenever a byte is received from the serial interface, an interrupt request is generated by the UART (U3). On seeing the interrupt, the data bus is configured to accept data transfers to and from the UART on bits 4 and 5. The UART has an SPI interface on its processor side, which uses synchronous data transfers.

Bit 1 is used to provide the clock for synchronising the transfer.

Bit 2 is used as a read/write control. While high, the data direction is from a port to the processor (read operation), when low the data flow is from the processor to the port (write operation).

Bit 3 is fed from the tone detect output of the MF tone decoder. When high, the processor is being advised that a tone has been received and decoded and is ready for use.

The data bus, which goes to all ports, comprises bits 4, 5, 6 and 7.

The highest priority for attention is the UART interrupt since missing its call for attention would cause data loss. The MF detector (U10) does not need such speedy response since its output will be active for at least 40mS, giving plenty of time for it to be polled in the normal cycling of the operating code.

Because there is a likelihood of bytes arriving at the serial port in rapid succession, faster than they could be processed in real time, a circular input buffer is implemented in software. Each received byte is added to the next empty space in a queue, the bytes are read out in the order they were entered as quickly as they can be dealt with. When the read position on the queue has caught up with the write position, the processor knows there is no more data available. The queue is eight bytes long and is a loop. In the unlikely event that so much data arrives that all eight positions are filled up, the oldest data is overwritten and lost. This scenario is unlikely to occur.

Also on the SYSPROC board are several of the peripheral ports:

All these ports are attached to the data bus to allow data transfer and to one line from the address decoder (U1) which activates only the one port being requested.

The OSG controller and generator. This provides the overlay text at the top of the screen. The special character generating device uPD6154 (U8) is driven from processor (U9) which translates the request for display into the special serial format used by the generator. In order to maintain a steady position on the screen, the generator is fed with horizontal and vertical sync pulses derived from the transmitter output signal.

The MF tone detector (U10) uses switched capacitor techniques to isolate two frequency bands from the receiver

audio input socket. When appropriate tones fall within both these bands, the detector works out the keypad digit that created it and notifies the main processor that it has done so. When addressed, the device presents a number representing the digit to the data bus where it is read and appropriate action taken.

The VCR control port (U11) when addressed, reads data from the data bus and translates it into a signal approximating to the flash sequence of an infra-red remote control unit. This is used to modulate a carrier (see SAP board) and then used to control the VCR. The device also controls the mains switching and power-up sequencing of the VCR. Note: an alternative processor (PB-Ctrl) may be plugged into the socket to allow direct connection or relay operation of the VCR should this ever be necessary.

The ID generator (U12) is used to generate and key the tones used for audio identification. When addressed it reads the data on the data bus and converts it to a pattern of marks and spaces which in turn enable a tone at 1010Hz. The volume of the tone can be dropped by command, electrically this is achieved by grounding the lower of the resistors in the potential divider on the output pin. Normally, the bottom resistor is allowed to float so it does not effect the output voltage. An LED is connected to visually announce tones are present, it illuminates whenever the tone output is turned on.

User Ports A & B (U4 & U5) are used to control the state of the relay outputs. They are not used internally in the repeater and are available for controlling any other devices or equipment at the repeaters location. Although the devices are programmed only to turn individual relays on or off, they have the capability of producing any single, multiple or simultaneous relay operation if so programmed.

The Antenna control and Weather satellite control ports (U6 and U7) are simply latched copies of the data bus. They have no 'intelligence' of their own. When addressed they copy the data on the data bus onto their output pins.

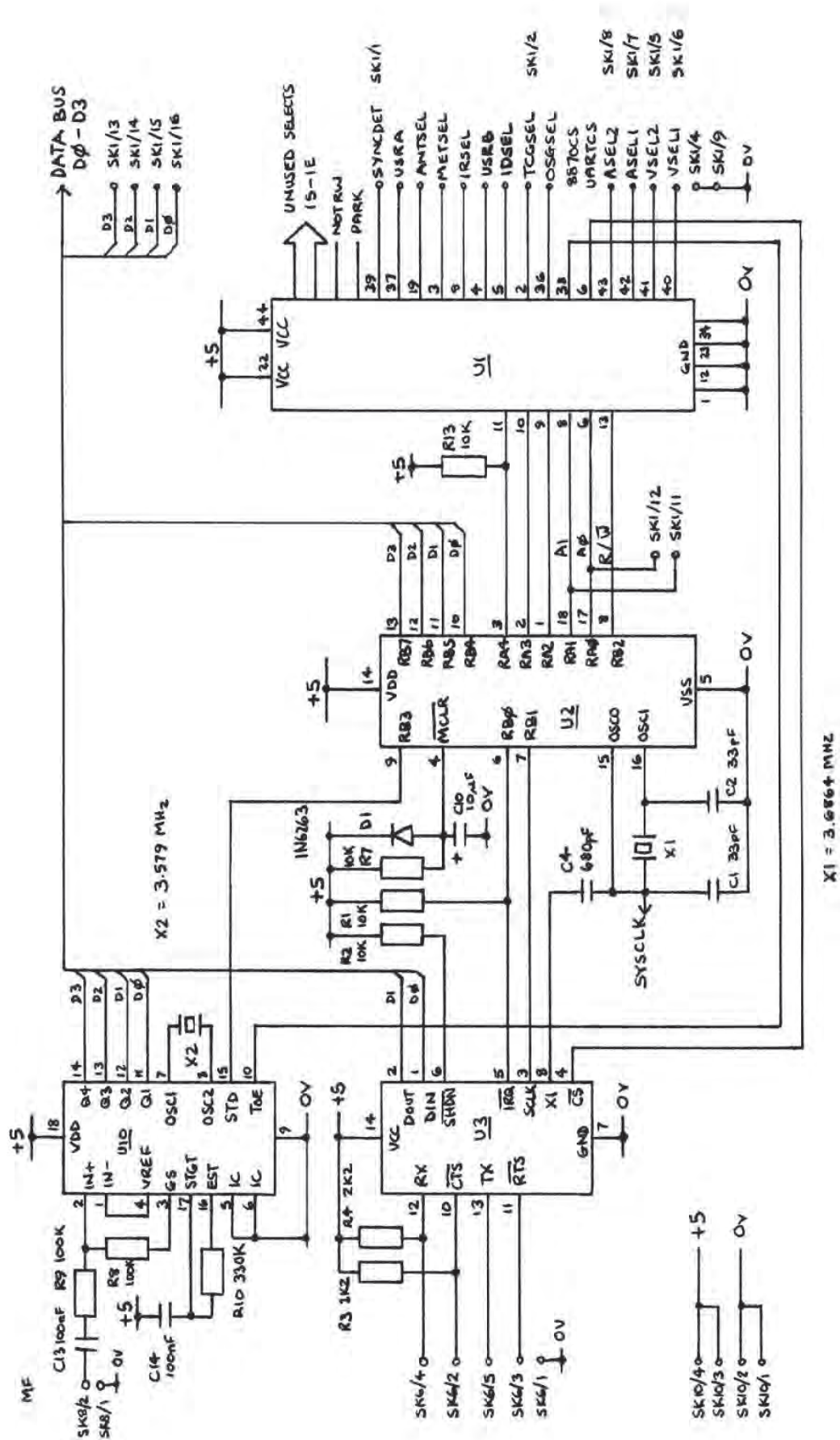

© GW16BNX

SYSPROC - SYSTEM PROCESSOR SHEET 1 OF 2

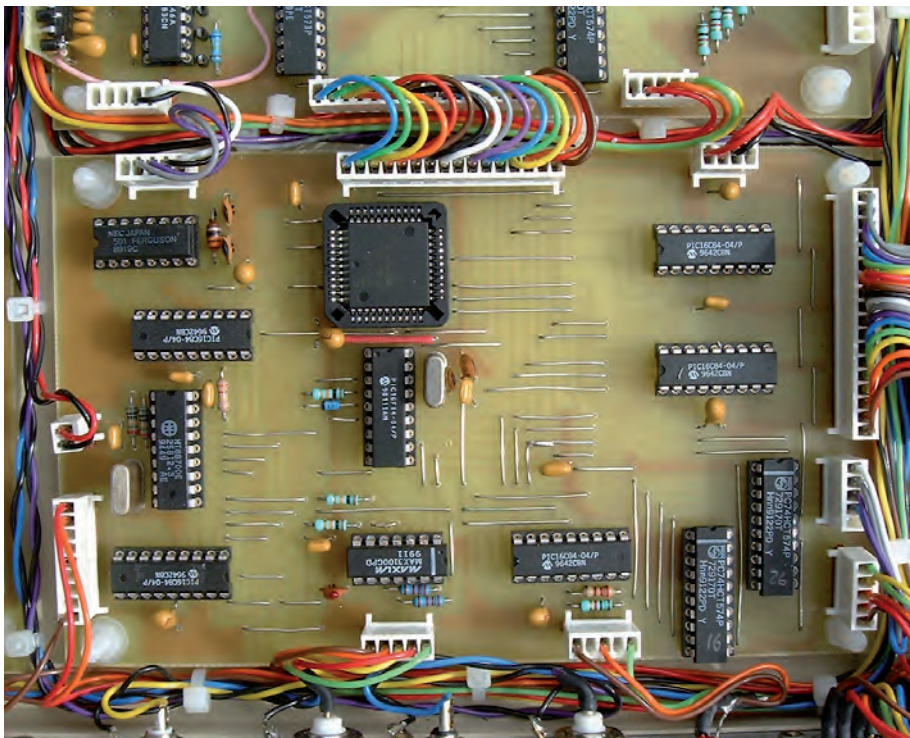

Photograph of the Sysproc board while in-situ in the enclosure. This is the prototype, and contains some very minor errors. The layouts below have been corrected.

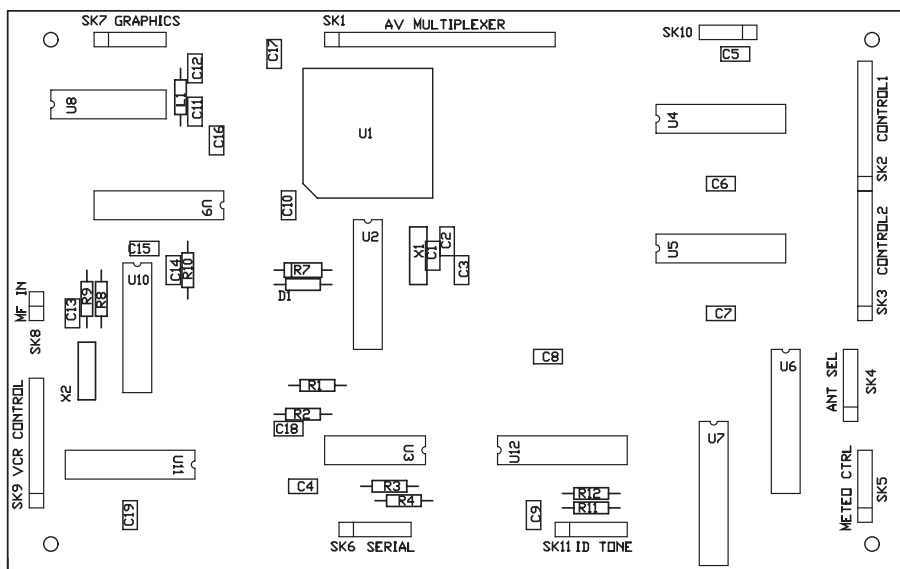

Component placements on the Sysproc board.

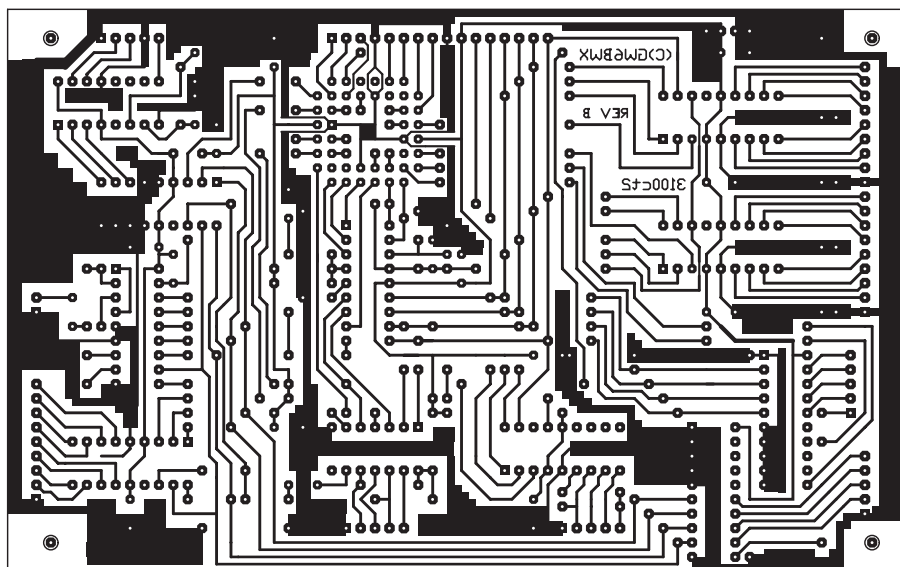

Copper track layout on the Sysproc board.

Printable full-scale layouts are available, see the text for more details.

SAP

The SAP holds the controlling processor, the infra-red carrier generator, the VCR power switching controller and the user port relay drivers.

The controlling processor (U15) is only used in stand alone mode. When a link is fitted between pins 8 & 9 of the computer interface socket on the front panel, the 'SEL' signal is grounded. This does two things, firstly it signals to the processor that an external computer has been attached, causing it to go into standby mode until the link is removed again. It also pulls the select pin on the PAL device (U13) to a logic low state which changes the signal routing so serial information from the UART (U14) is disconnected and the front panel socket is instead routed to the SYSPROC.

The SYSPROC has no knowledge of whether the SAP or external computer is in control since they use identical signalling protocols, however, should it ever be necessary to give it his knowledge, the RTS and CTS lines can be used to provide additional control signals.

The UART operation is identical to that on the SYSPROC except that the receive queue is only four bytes long. As the SAP initiates responses it has better control of the data flow so the queue does not need to be as long.

There are several sets of linkable pins on the SAP board. The three near the power connector are for system configuration and link 'east-west'. Only the two pairs nearest the power socket are used. Fitting a link to the pins nearest the socket causes a personality change, all the test card pages, identification messages and on-screen graphics become those for GB3XG instead of GB3ZZ. The middle pair of links are for controlling the start-up of the VCR. If the link is fitted, in addition to the power sequencing, standby and rewind when the system is started, a channel step down command is also issued. If the VCR requires it, this will step the channel from 1 (default at power-up) to 0 which enables its start inputs.

The pins between the UART and Processor, when linked put the processor into a reset state. Momentarily joining them will restart the SAP processor and if it is in control of the system (computer not plugged in) the whole repeater will re-initialise.

The pair of pins between the UART and its XTAL should NOT be joined. When a link is fitted it makes the UART share its clock with the processor. The UART clock must be 3.6864MHz or the baud rate of the serial link will be incorrect. If a link is fitted, the oscillator components X1, C3 and C4 must be removed and the processor clock must be slowed to 3.6864MHz.

The last pair of pins is beside the PAL (U13), these replicate the connection at the computer socket on the front panel and are used for software debugging. When the link is fitted, the on-board processor is disabled and the PAL routes all serial information from the front panel socket to the SYSPROC.

The relay driver section of the PCB consists of 16 identical darlington transistor stages, each operating one relay. The relays are in two groups, each group has a common connection and eight switched connections. The common connections and all switched connections are isolated from each other and to ground. The relay contacts are rated at 100V 0.5A and the isolation to ground is rated to 1KV although it is recommended that no more than 750V is applied.

The infra-red carrier generator is a keyed 37KHz oscillator which produces a near square wave output suitable for driving two infra-red LEDs. One LED is mounted on the front panel, the other is available at the DIN front panel socket. The current from the latter is limited to approximately 50mA, allowing direct connection to an LED without requiring further current limiting.

VCR power switching is necessary as there is no way of telling whether the VCR is in standby mode or not. To ensure its state is known, the power must first be removed, then re-applied. This ensures the VCR starts in standby mode. IR commands to leave standby and rewind the tape are then issued by the IR controller on the SYSPROC board. As the power switching involves mains voltages, it is not done inside the repeater box, provision to control the power switching is provided instead.

Either a small relay can be used or preferably, an opto-isolated triac switch. The signal to operate the switch is a DC output which is close to 5V when on and near ground when off. For safety reasons, it is current limited to about 100mA although the suggested maximum load is 50mA. It can

withstand continuous short circuit and up to 50mA reverse current (entering the output connection) without harm. The power output is ground referenced and should not be connected directly to any mains voltages.

Although not fitted to the SAP board, provision is made for an alternative, linear power supply. This consists of two bridge rectifiers and three voltage regulator ICs. The regulators may be bolted to the base of the box through suitable insulating washers so it can act as a heat sink. Note that the reservoir capacitors are not mounted on the PCB but can be connected to the pads provided.

To produce your own printed circuit boards you need to download the copper track layouts from :

www.atv-projects.com

where the original design files and printable PDF copies can be obtained.

All the repeater boards and files to program the microcontrollers and PLDs are available. Although the repeater is 'ready to go' it can be customised to individual requirements very easily. So that the processor code can be modified, all the source codes have been presented for downloading.

To modify the PCB files you will need to load the design files into Protel's Autotrax program which is available at :

<http://www.altium.com/community/support/downloads>

To modify the program source code you will need Microchip's MPLAB assembler which is available free of charge from

<http://www.microchip.com>

When the original programs were written the current version of MPLAB was 6.4. Since then, new versions have been produced, the latest being version 7.51. All the files have been tested with this last version and assembled without any errors.

The author can be contacted about design issues at the address on the www.atv-projects.com web site.

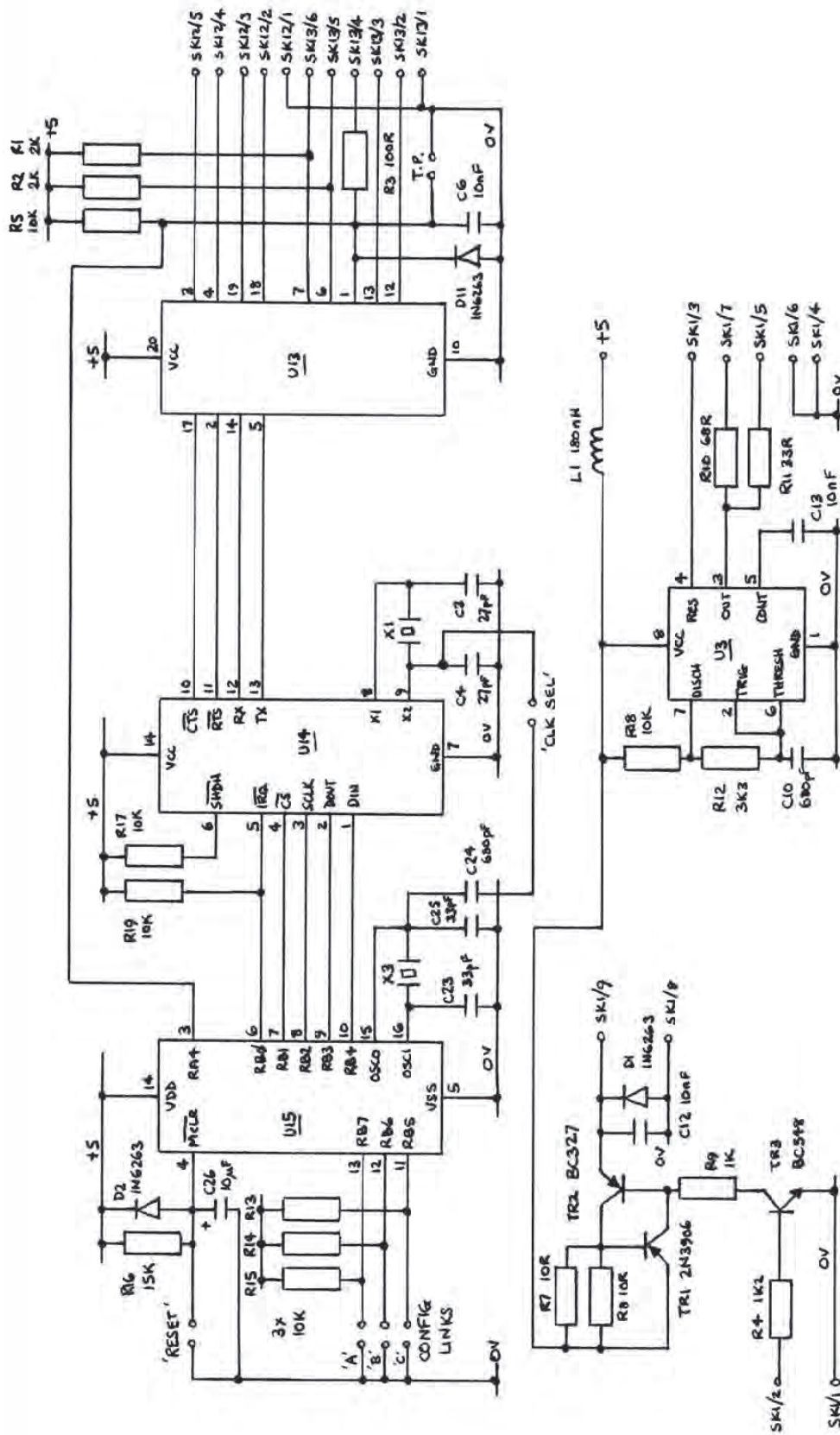

X1 = 4.096 MHz
X3 = 3.6864 MHz

SAP SHEET 1 OF 2

© Gw6BwX

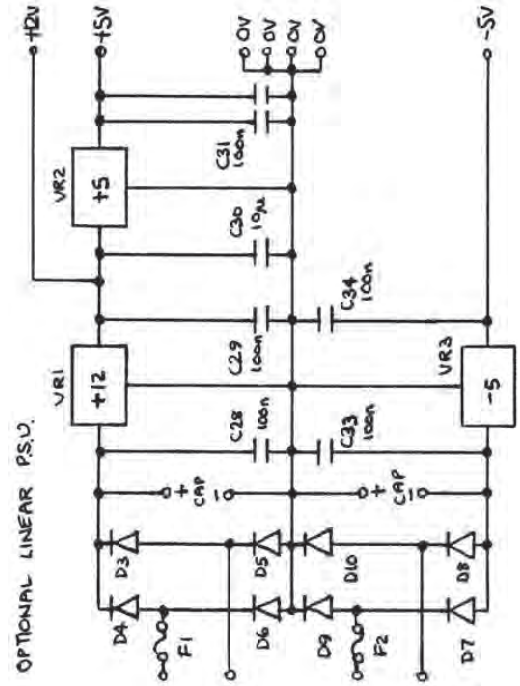
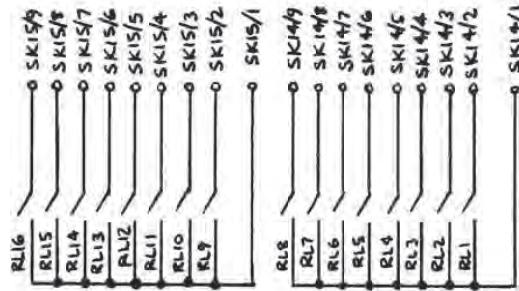
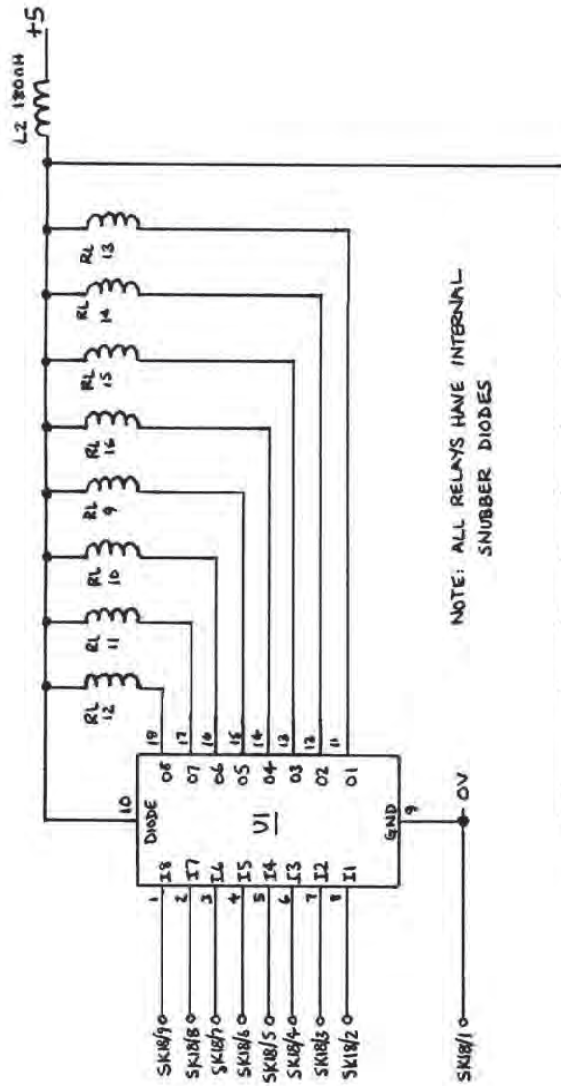

SAP SHEET 2 OF 2 © GW6BWX

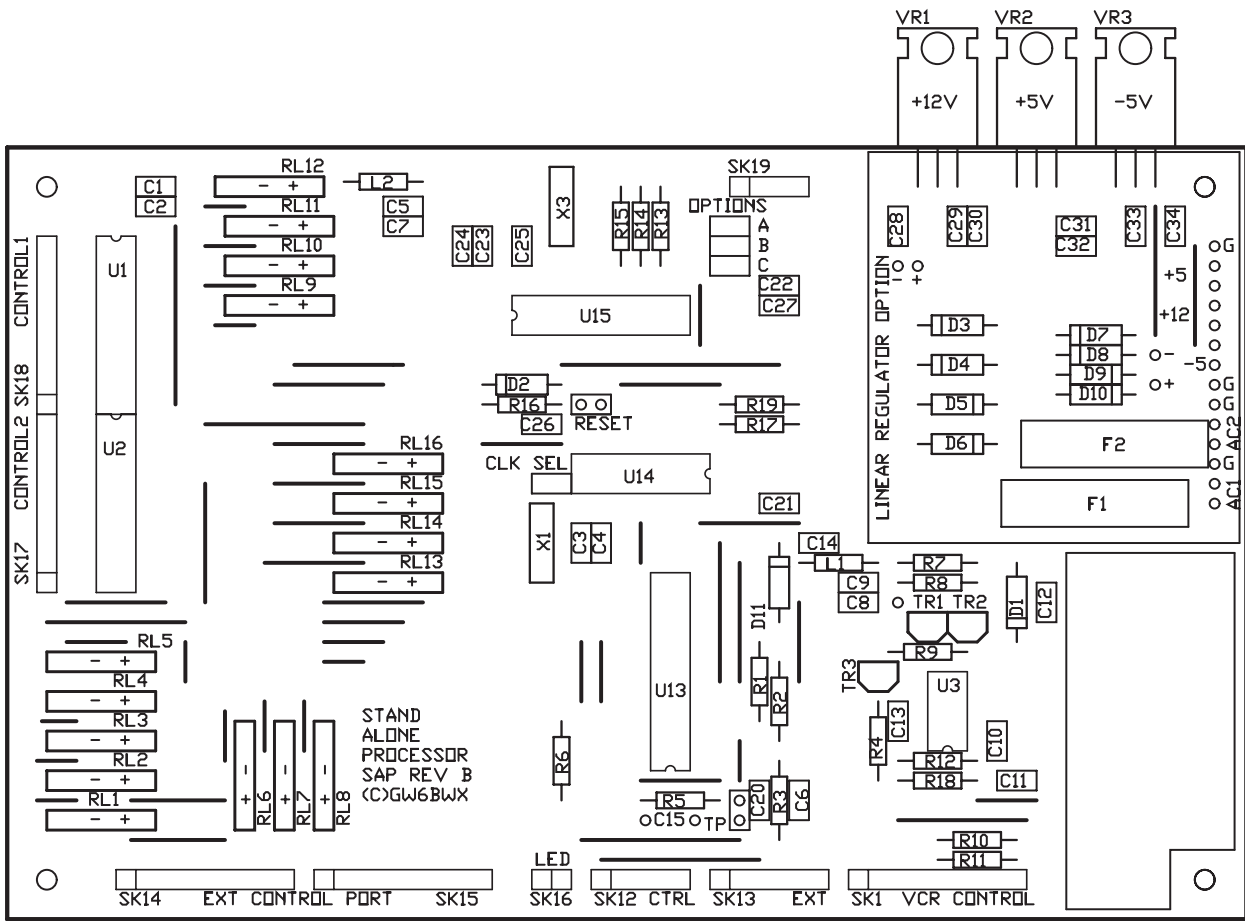

Above: SAP component layout. The components in the top right corner are the optional linear power supply.
 Below: The SAP copper track layout. The pad array is just a patch area for expansion if needed..

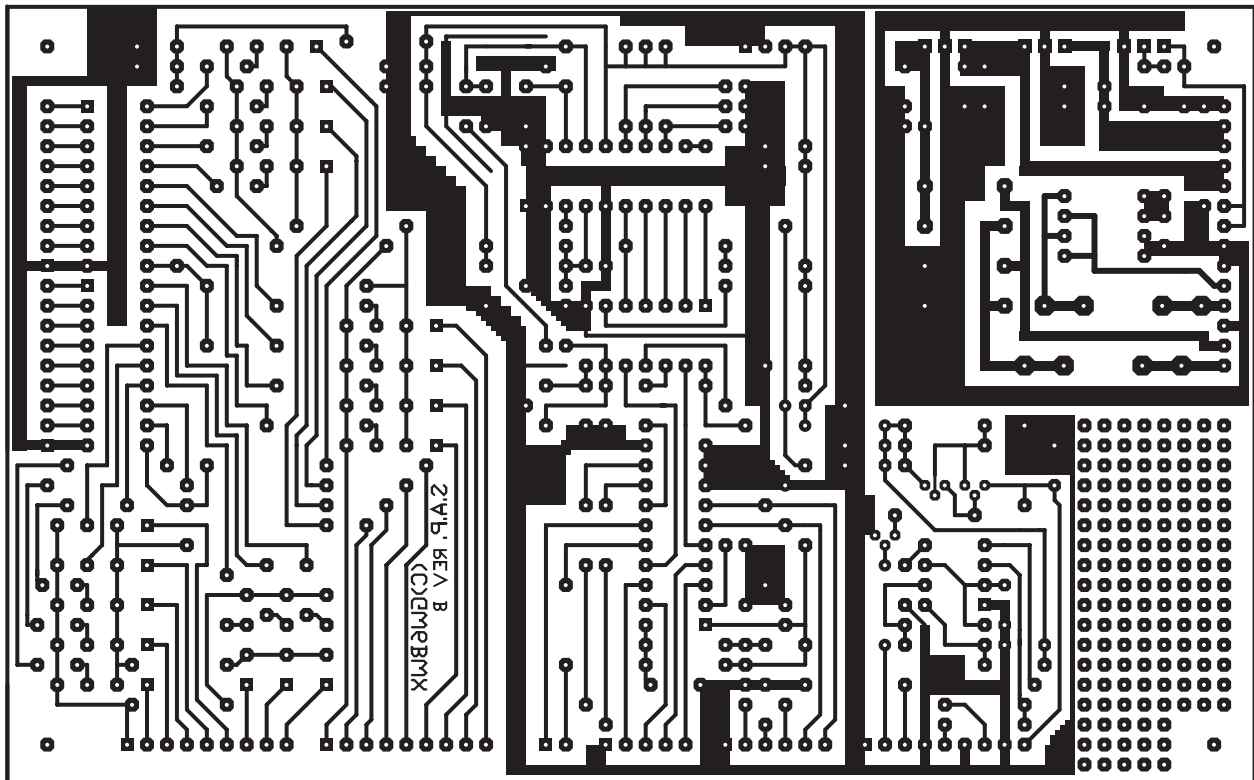

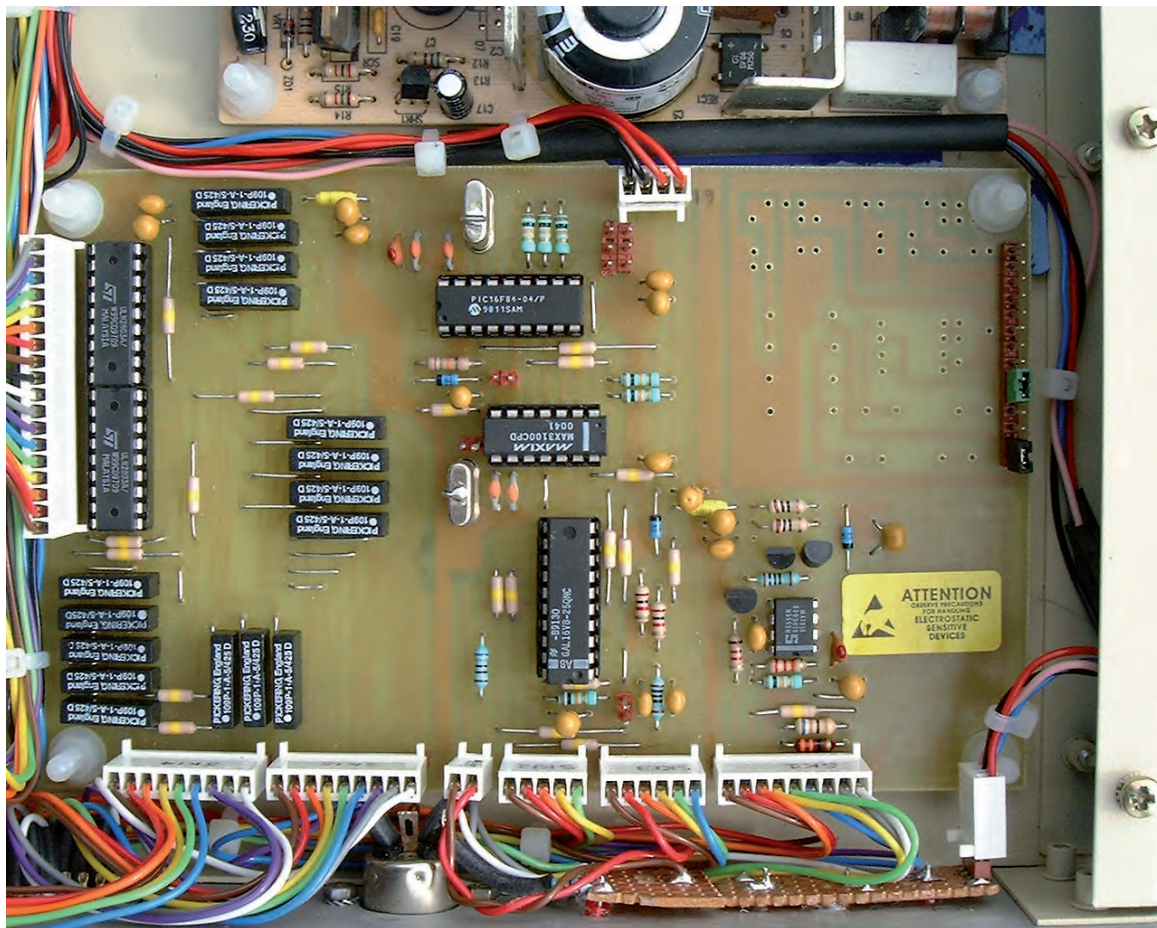

Photograph of the SAP board. The jumper links in the top right corner are stored in case they are needed on the main part of the board. There are no components connected to the row of pins, they are reserved in case a linear power supply is used.

We have produced a DVD containing electronic versions of CQ-TV and the CQ-TV articles index. Also included are electronic versions of our three most recent handbooks, 'Slow Scan Television Explained', 'Amateur Television Handbook' and 'An Introduction to Amateur Television'.



The archive is constantly being updated as more of the old paper issues are converted to electronic format. Currently issues 1 to 134 and 161 to 216 are included along with a few odd ones. This DVD is updated 4 times a year, to include the current issue of CQ-TV.

The DVD is playable in a standard (domestic) DVD player (and on a PC with a DVD player) and the data files will 'auto-run' when the DVD is put into a PC.

The video section was prepared by Brian Kelly and contains videos from Bletchley Park 1999, one from Shuttleworth 2002 and one from 2004. The cost for this DVD is £5.00 for current members and £10.00 for non-members.

Note: This DVD is supplied on +R media only.

A Question of Gamma

by Ian Waters. G3KKD

As I usually write about radio frequency topics I find myself on strange ground writing about gamma.

I recently bought myself a new camcorder as the one that had served me very well for 10 years was hardly any more state of the art.

I invested in a Panasonic NV-GS75EB digital camera with 1.7 Megapixels and separate sensors for R, G, and B. This small device in the palm of the hand produces video pictures comparable with those we obtained from massive broadcast cameras only a few years ago. It also offers the extra facility of doubling as a still photo camera either by selecting the picture mode, or pressing the photo button while recording video, in which case it grabs a frame onto the SD card. My decision was partly prompted by objections from the distaff side about my carrying too much kit when going out on visits.

Reviews in magazines said that providing a still photo feature on a camcorder is at best a compromise and one should not expect very good results. Nowhere did they say what aspects of the photos taken would be inferior.

With 1.7 Megapixels being a lot less than the number provided by a modern digital photo camera one would expect pictures to lack resolution. In practice while they would not stand too much enlargement, they are perfectly adequate for 4x6" photo album type records. If I want to take higher quality pictures for enlargement I still use my SLR film camera.

I was however very disappointed to find that my photos looked muddy with no detail in the darker areas. As the pictures on the computer monitor looked fine I suspected a problem with my printer.

Then the penny dropped, it seemed to be a problem of gamma. A television

camera processes video in a gamma correction stage ($\gamma=0.4$) to compensate for the assumed gamma characteristic ($\gamma=2.8$) of television display devices. Presumably this correction remains in circuit when in photo mode leading to the crushing of the black areas. I wonder why the designers of the camera did not arrange for it to be switched out?

The cure I have adopted is to import my pictures into Photoplus, go to colours, adjust and gamma. The gamma can then be set to somewhere in the region of 1.2 to 1.8, the best setting being found by trial and error. All is then well.

In writing this I am probably telling some people what they already know, but as I have never seen this issue described anywhere others may be as perplexed as I was.

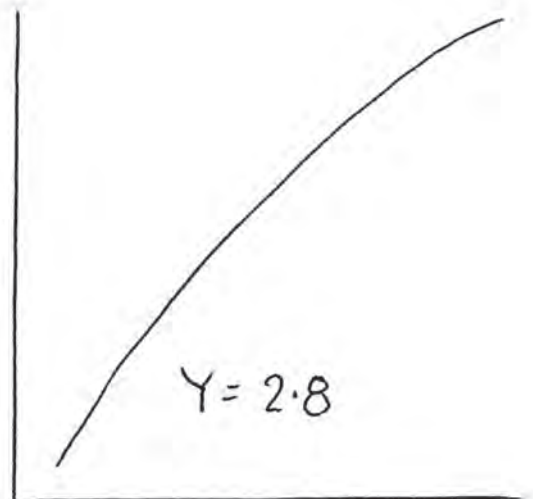
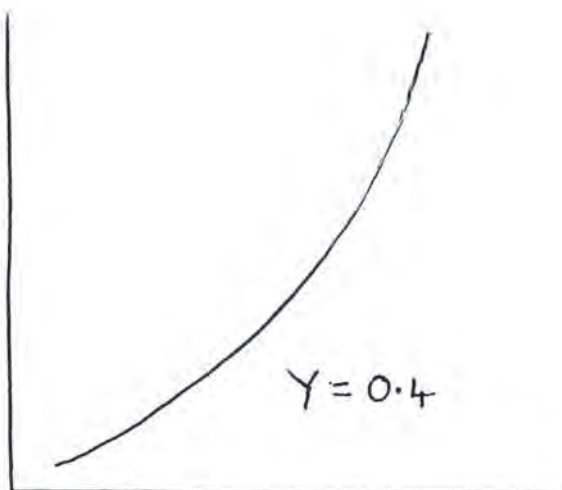

"Turning Back the Pages"

A dip into the archives of CQ-TV, looking at the issue of 50 years ago.

by Peter Delaney

CQ-TV 31 - "Winter 1956-7"

The main 'news' article described the Club Convention, held in London. 141 members attended - twice as many as the previous year, and there were "visitors from Tasmania, the Netherlands, the Channel Isles, and from Northumberland and Cumberland amongst the further English counties". Exhibitors included not only members displays, but also 'professional exhibits' by Pye, Solartron, Telequipment, Illife, Norman Price, STC, Mullard and Proops. Amateur displays included the High Wycombe group - "all of their very well made equipment was on view, although it is not yet in a working state", and Mike Cox - "unfortunately the equipment did not enjoy its day out in London, and was performing very poorly; it worked perfectly immediately on switching on back at Chelmsford again, as one might expect (Sodd's Law)". Other large displays were put on by G3CVO, G2WJ and G2DUS, whilst in a corner G3KKD (Ian Waters) had a 70cm converter to relay pictures from the Cambridge group camera. The latter was described as follows:- "With due respect to the exhibitors, however, pride of place must go to the OB unit outside in the street. As the photos show, a really ancient London taxi, with suitable inscriptions upon it, carried a static camera and a V aerial on the roof, a petrol generator on the luggage grid, and the CCU and transmitter inside the passenger space. This remarkable vehicle travelled down from Cambridge in the morning, and was a centre of attraction in Queen Square, as will be imagined. The pictures transmitted were excellent, and when an equally old taxi appeared being towed by a breakdown truck, the OB unit hotly (and noisily) pursued it nine times round the Square. No cameramen were lost, although the constant buffeting from viewfinder hood in front and aerial mast at the rear must have given them some real headaches! Words cannot do justice to this very fine effort produced by members of the Cambridge group, but we should say that the taxi itself was at least as much a technical success as the vision gear".



The pictures show 'Matilda' - as the taxi was fondly known - with Ian on the roof; the control gear installed in the taxi passenger compartment - an oscilloscope and transmitter on the top and picture monitor and camera control on the bottom; and the picture from the street as received inside the Convention.

A slightly surprising topic, maybe, to find at that time in an amateur context was a piece about video tape recording. It was suggested that 'we could do this easily using 30 line 25 picture standards'. It was shown that the video bandwidth for such a signal was about 15kHz, "well within the capabilities of the average tape recorder at 15 ins/sec". The item added that "30dB is considered to be a reasonable signal/noise ratio for video work; the

Ampex video tape recorder does that on a 2" tape @15 ins/sec, obtaining 4Mc/s bandwidth and so giving 320 line definition on the 525 line system".

More in keeping with the technology of the time was instructions on how to make a rotating polygon film scanner. A piece of unscratched perspex 1/2" thick was turned to 2.28" diameter, and then 24 faces milled onto the surface. The polygon was then driven at the same rate as the film, and scanned by a crt, so that the light beam was picked up by a photo electric cell - the diagrams give the general idea. (How many of today's amateurs would give access to a lathe or milling machine, for such mechanical work?)

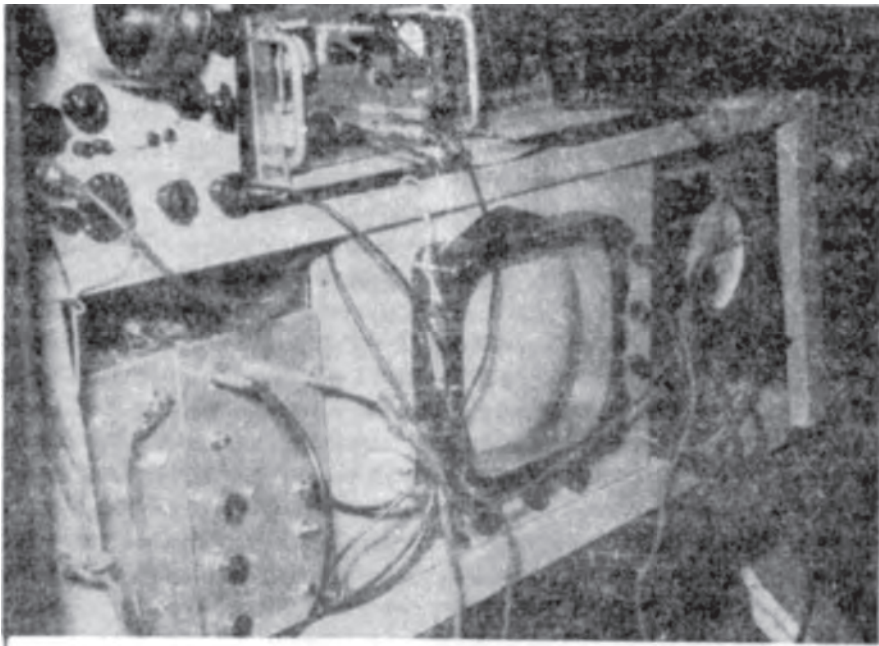

Left:
Matilda's control gear

Below:
Rotating polygon film scanner

Street picture received at the convention.

CQ-TV has often helped Club members to discover 'new' technologies, and this was as true in 1956. At that time, "transistors tend to be a mystery to the average amateur, perhaps because of the amount of mathematics apparently required to understand their operation. It should be remembered that a similar state of affairs existed with the first valves - they were expensive, not fully understood, and regarded with awe. Fortunately, just as with valves, it is not essential to understand all about transistors in order to be able to use them in circuits." At that time, circuits were included using junction transistors and point contact transistors.

Many amateur television activities relied upon several members putting equipment together for exhibitions etc. CQ-TV 31 included the recommendation that "the proposed standard is:- 'All BATC sync generators shall be fitted with a Belling-Leesocket for accepting either Line Sync only or Mixed Sync information from a remote source (at standard level), together with such circuitry as will enable the sync generator to be genlocked to the remote source'." (It appears that many amateurs locked their equipment to the local BBC or ITA transmissions, as by doing so the weak amateur signals could be more reliably locked than when relying on the amateur transmitted sync pulses).

(Have we progressed a great deal? - many members these days rely on commercially available cameras etc as picture source - items that do not have a genlock input, and not even a common connector standard !!)

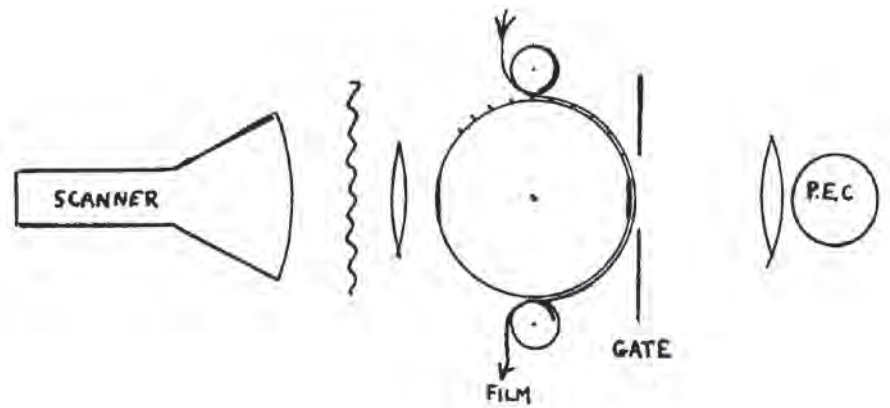

Note that the film gate must be three frames high although only two adjacent frames at any one time contribute to the picture.

Figure 3/4: Optical path in the polygon scanner



A CVBS to YC Splitter

by Tony Jaques. G3PTD

After a complete re-cabling of my video editing setup to use YC ("S-Video") throughout I realised that I no longer had a way to line it all up!

My line-up source is an Ikegami HL95 ex-ENG camera. Because I have never had a lens it is used only as a source of rather good EBU colour bars, but unfortunately the only output available is a composite encoded signal (CVBS). Clearly I needed to generate a YC signal from it. A look around the web revealed only joke solutions such as a 1nF capacitor in series with the signal to provide a chroma output, so also clearly I needed to provide my own solution. The result is presented here in case it may be of use to anyone else.

The circuit

The circuit has very little that is startling, and the individual circuit sections are hardly original - except that I have not seen the simple filtering before. The CVBS input is applied to an emitter follower TR1. This is not so much for isolation; more to provide a low impedance feed to the chroma filter in the luminance section.

The Luminance section

From TR1 the signal goes two ways. The upper path in the circuit starts with a series resonant circuit to "short" the chrominance signal to ground. Because of the low impedance source the 2.2K feed resistor is in parallel with the tuned circuit and dampens it. We don't want a sharp resonance here; the idea is to attenuate all the chrominance signal, not just the subcarrier. Even so, the trimmer was found to be necessary to achieve best rejection overall. After a further emitter follower there is a fairly standard output stage with sufficient gain to compensate for circuit losses and provide two volts of signal for a terminated feed. The 68 ohm resistors were found by trial and error to give the correct source impedance. As can be seen from the photograph, the chroma attenuation, although not total, is quite good.

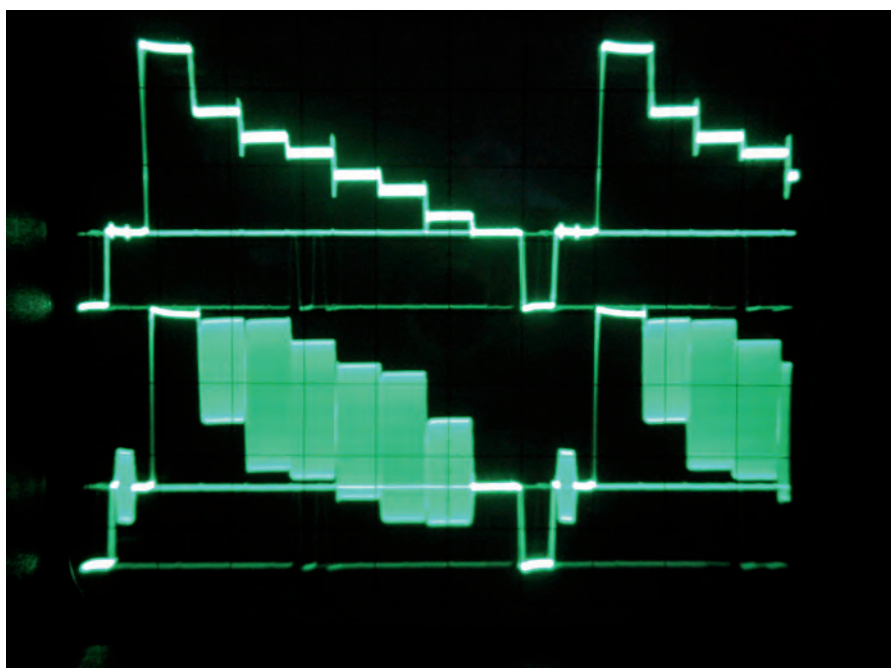
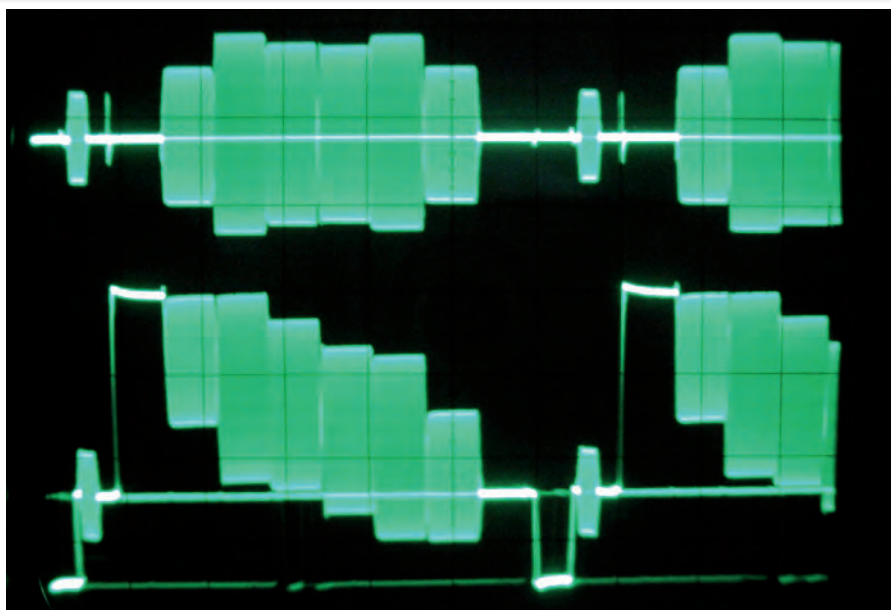

The chrominance section

The lower chain is very like that of the luminance section, but the signal is taken from across the inductor. Really this filter performs more as a high pass filter than a resonant circuit, the 33pF series capacitor providing a high attenuation of the low frequency signal components. If a multiburst signal is used it can be seen that the high frequency components above some

4MHz are barely attenuated.

Again the photograph shows a useful degree of separation, but on examination it can be seen that the leading edge of the white bar does show as a spike on the output.

Components and construction

There is not generally anything special about the components. The inductors were the small axial lead types, but

any other should do. The transistors were types that I happened to have plenty of, with one exception. A 2N3904 was used for TR2 because of its low Cob, compared to the BC172. My version was built on Veroboard with a layout that closely matches that of the circuit. The only special measure taken was to remove any unused track in the filter

area. It may make no difference; it just seems to me to be a good practice. The gain controls could be panel mounted, but the project is not really intended to be an equaliser. For its function as a unity gain device on board presets are appropriate.

No miracles! Lest anyone be fooled;

This circuit does not of course provide a true YC signal. Any cross colour artifacts on the source video will still be there. The circuit may provide a convenient YC signal where it would otherwise be none available, but it does not work miracles. The output is no better a video signal than the source was!

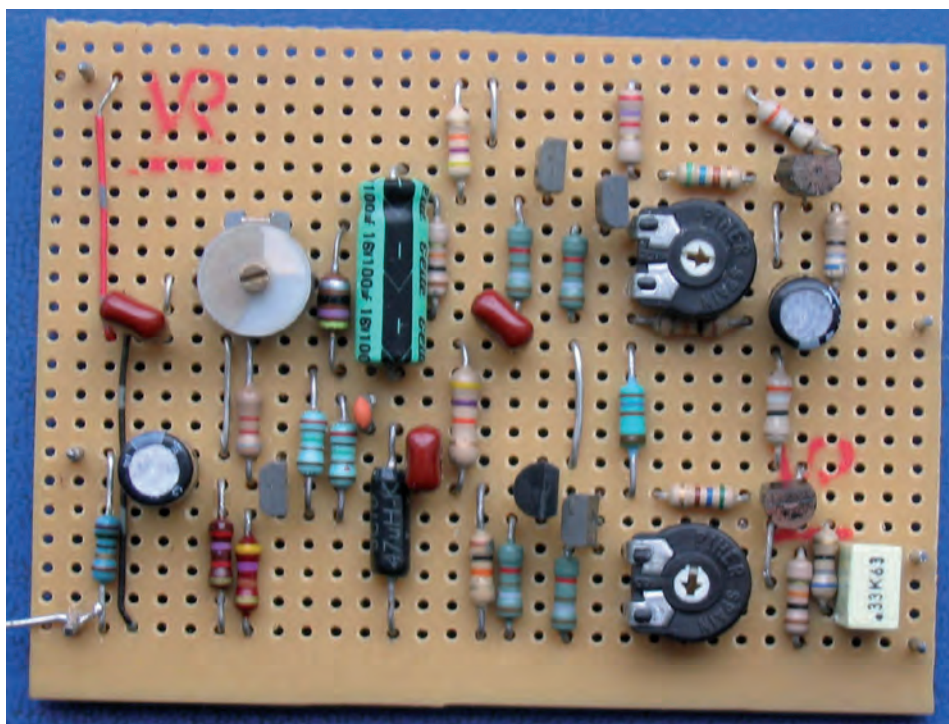
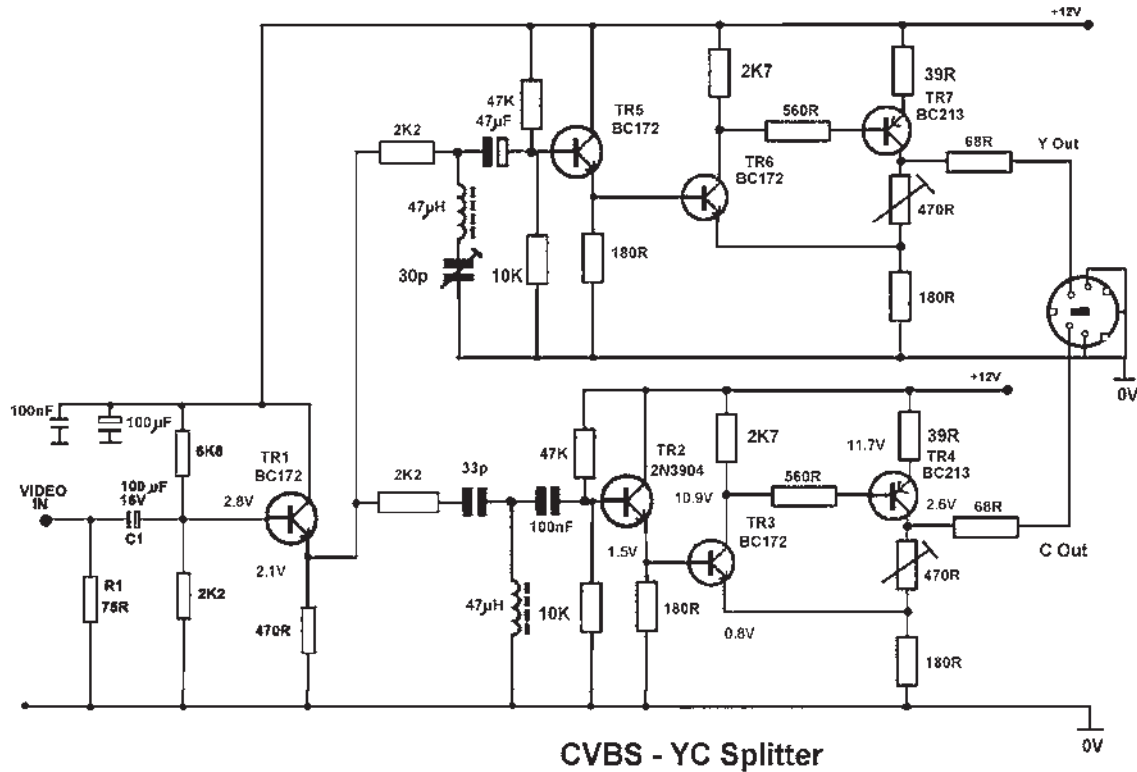

Veroboard layout.

Note that on this board, two additional capacitors are fitted. These were to DC block the Y and C outputs but should not be fitted for normal use.

Embedded Audio

By Mike Cox

Introduction

Routing signals around a production or play-out centre becomes increasingly complex, particularly when more than two audio channels have to be routed with the video. In the early days of digital video, video signals were routed as parallel streams to CCIR Rec. 601. Audio was routed separately, either as analogue or digitally as AES/EBU streams.

Increasingly, embedded techniques are in use. An early one familiar to many is the DV specification, closely allied to Firewire/I-Link technology. Audio, Video and control signals are all together in a 25 Mbps stream. This however is compressed, and may not be of sufficiently good quality to stand further manipulation in editors. Most studios use SDI [CQ-TVs passim] for interconnect purposes, and increasingly, the SDI stream carries embedded audio. This will pass transparently through SDI and HD-SDI routers.

In CQ-TV 216 [p. 17]. I mentioned problems I had at IBC this year with SDI signals carrying embedded audio. This mainly affected certain decoders that I was using in monitors, but the mixer fade to black card was similarly affected.

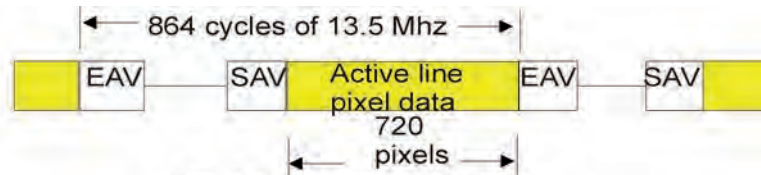

Fig. 1a Position of TRS-ID

Bit No	9	8	7	6	5	4	3	2
Word 1	1	1	1	1	1	1	1	1
2	0	0	0	0	0	0	0	0
3	0	0	0	0	0	0	0	0
4	1	F	V	H	P	P	P	P

1 = EAV
0 = SAV

Fig. 1b SIMPLE TRS-ID DECODE TABLE

It seemed appropriate to investigate further, and what follows is the result. It is all tied up with separation of video and audio samples.

Timing Reference Signals

We need to look at the blanking intervals to see where audio and ancillary data can be put to give maximum capacity, and with no disturbance to video. The start [EAV] and finish [SAV] of blanking intervals are given by the TRS [Timing Reference Signals] sections in the 601 parallel stream. A TRS is defined by a group of 4 words starting with 3Fh and then followed by 2 words all 0s and then a word defining whether it is

Vertical or Horizontal blanking, or odd/even field. Fig 1a shows position of TRS-ID words, and Fig. 1b shows decode table for them.

Fig. 2 shows the four most significant bits of a 601 stream at the EAV TRS, without and with embedded audio.

Note that this structure applies for 8 bit or 10 bit 601 streams. In the 10-bit case, the two lowest bits are ignored.

However, SDI with embedded audio will not pass through an 8-bit system with audio intact.

In a simple world, an 8 bit AND gate will only give an output when all bits are "1". This is the opening condition for a TRS-ID. Normal video never reaches 3Fh [FFh for an 8 bit stream]

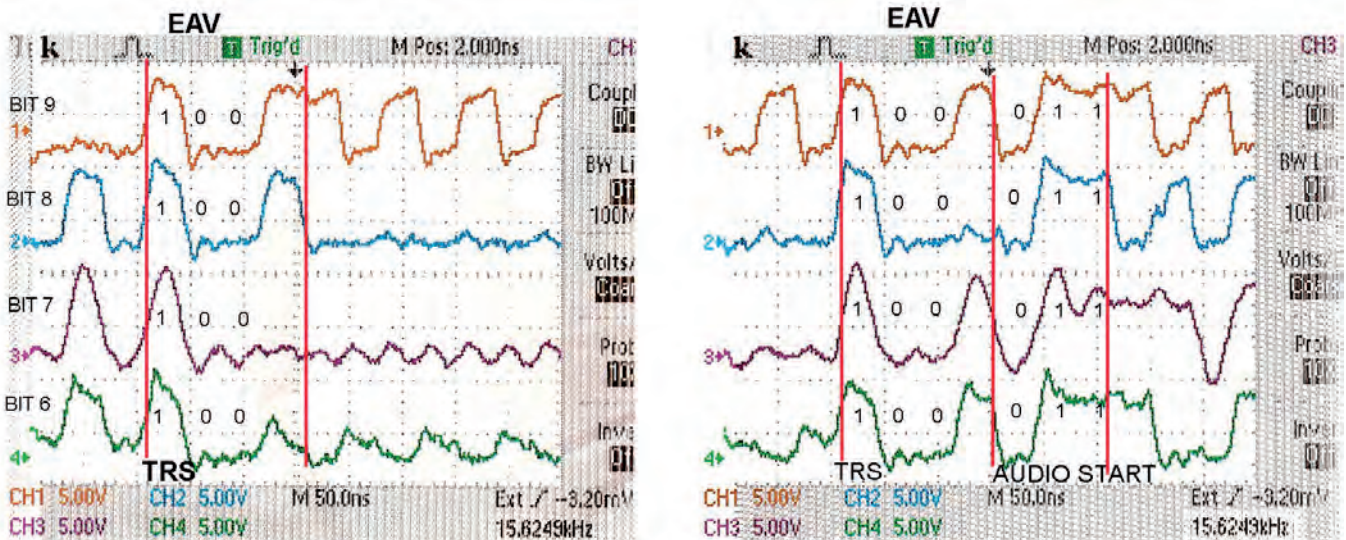

Fig. 2 ACTUAL EAV SIGNALS WITH EMBEDDED AUDIO

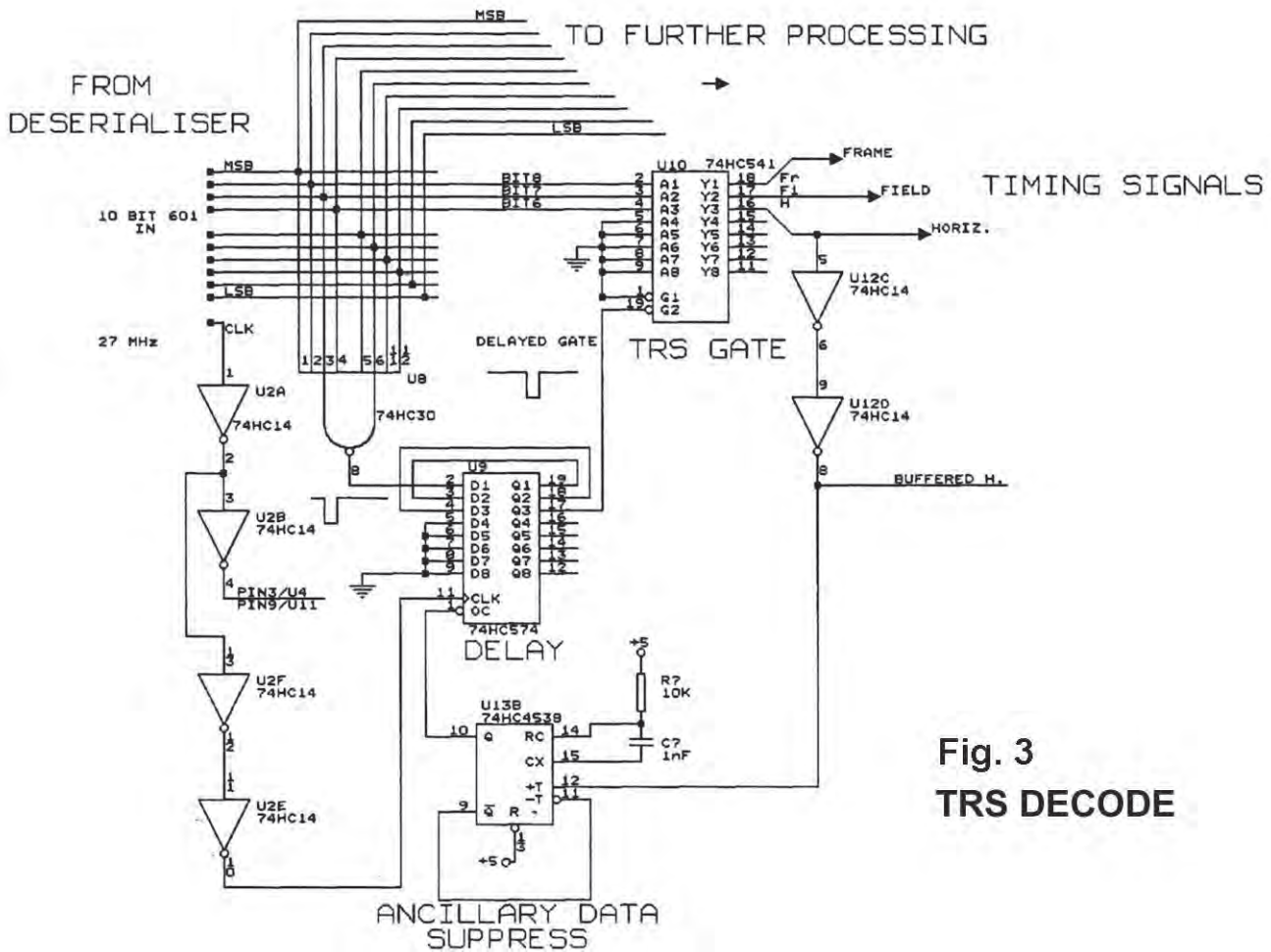

Fig. 3
TRS DECODE

or goes to 000h, as it should be limited at 3ACh and 040h, so the gate should never give an output with normal video. As soon as an EAV or SAV comes along, the gate will give an output for 1 clock cycle. If this is delayed for 3 clock cycles, it can be used to gate bits 8, 7, 6 to derive F, V or H signals.

All seems well. [Fig. 3 Simple TRS Decode circuit]

However, the flag for the audio/ancillary data block is the reverse of the TRS-ID in that it starts with 000h for 1 clock and then 3FFh for two clocks. The simple TRS decode system will respond to this and try to gate bits 3 cycles later. These may well be audio preamble bits, and will be rubbish as far as video is concerned. The effect shows up as frame bars running through the picture.

The first step is to inhibit the bit stream to the decoder after the first TRS-ID, for around 11 microseconds. The monostable in the circuit is one way to achieve this.

Obviously, a similar technology can be used to decode the start of the audio/ancillary data block.

Audio Digitisation

The standard or default version of SDI with embedded audio assumes 20-bit sampling at 48 KHz, and with this data rate, up to 16 channels of audio in 4 groups can be used. Note that the audio sampling frequency must be locked to the video clock.

Audio will most commonly be digitised as an AES-EBU stream. This is the most common format within broadcast systems. This may seem like an amazing amount of data, but if you consider a 10-bit parallel stream [CCIR601], there is a great deal of space in the blanking intervals, particularly with a 27 MHz clock rate. The 20-bit audio sample is divided up into 3 9-bit symbols, to fit in place during the audio/data intervals. Each full sample occupies 111 nS. The specification allows for up to 16 audio channels in 4 groups. But we need to consider how to get from analog audio to an AES/EBU stream. Experts can skip this bit; audio novices like me have to consider the nuts and bolts.

Video employs standard analog to digital converters [ADC] and straight binary coding, albeit with restraints on levels such as setting black level to 10h, or ensuring that peak white does not exceed EBh.

Audio is tricky in that it is symmetrical about zero. Straight binary coding is not much use in such a case, and so called "two's complement" coding is used. In a manner not dissimilar to the sampling of colour difference signals, the audio input to the ADC is "sat up" by half the peak amplitude, fed into a binary ADC, and the MSB of this inverted. [Fig. 4 basic two's complement coding]

The resulting coded signal can be digitally mixed with other similar signals. The parallel stream has to be serialised and have the 4-bit preambles and 4-bit post-ambls added.

Some may ask why it necessary to have 20 bit coding. Video has defined levels, and tests have shown that 8 or 10 bit coding is adequate for a high quality display. Audio on the other hand has a much higher dynamic range, particularly for music. CDs have 16 bit coding with 44.1 KHz sampling, which

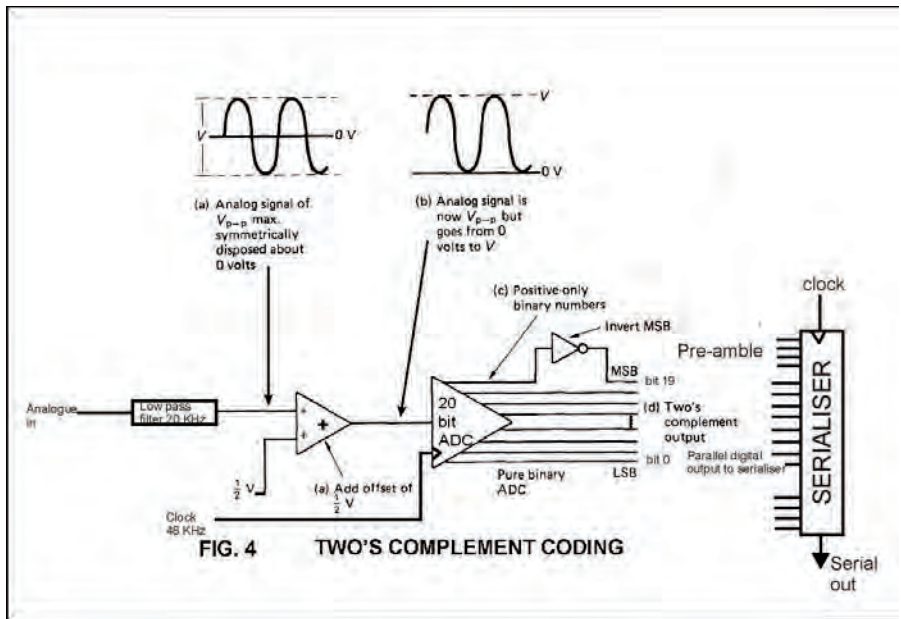

about with signal content. Furthermore, polarity is unimportant, so a crossed cable does not cause a problem.

Embedding

This is a step on the way. To embed the audio, Gennum [and others] make chips called Embedded Audio Coders [GS9023B for SD SDI, GS1503 for HD-SDI]. They take in 10-bit 601 video and serial AES/EBU audio signals.

These can be used as multiplexers, to embed audio in the video stream, or as de-multiplexers, to de-embed the audio from the incoming video. Because the digital audio signal has to be packetised in to fit into the data slots in video signal, and when the signal is recovered, FIFO memory buffers have to be incorporated to ensure that the digital audio is restored to a continuous stream. [Fig. 7 shows simplified block diagram of embedder/de-embedder]. Gennum also make a chip [GS4901B] to generate the clock signals for video and audio; usually 27 MHz and 6.144 MHz.

The multiplexing and embedding process can result in delay between audio and video. If this exceeds a very few frames, it is extremely annoying. Steps need to be taken to correct this, and the GS9023B provides means to correct delay errors.

many say is not enough. The standard AES/EBU specification is based on 20 bit coding and 48 KHz sampling. The nominal audio bandwidth is 20 KHz.

To simplify distribution and to use existing audio cabling, the digital code is sent as a serial stream. This stream has to be formatted in Manchester or bi-phase mark code to be self-clocking. [Fig. 5 Bi-phase Mark Coding]

The result of this is a serial stream of bits at 3072 Kbp/s. At this point the sample has to be put into the sub-frame structure, in which the 20-bit sample fits into the 32-bit sub-frame. [Fig. 6

Sub-frame and frame structure]

Two sub-frames form a frame, and 192 frames form a block. Each block carries a deal of data for synchronising, status, source and destination identification etc. The finished stream is transmitted using a balanced interface, usually at 110 ohms impedance. Other variants include an unbalanced 75-ohm system using coaxial cable, a consumer option, and a fiber optic version. All these system share the basic requirement of being self clocking, and dc-free, so that slicing at receive points is always about the center point, and does not wander

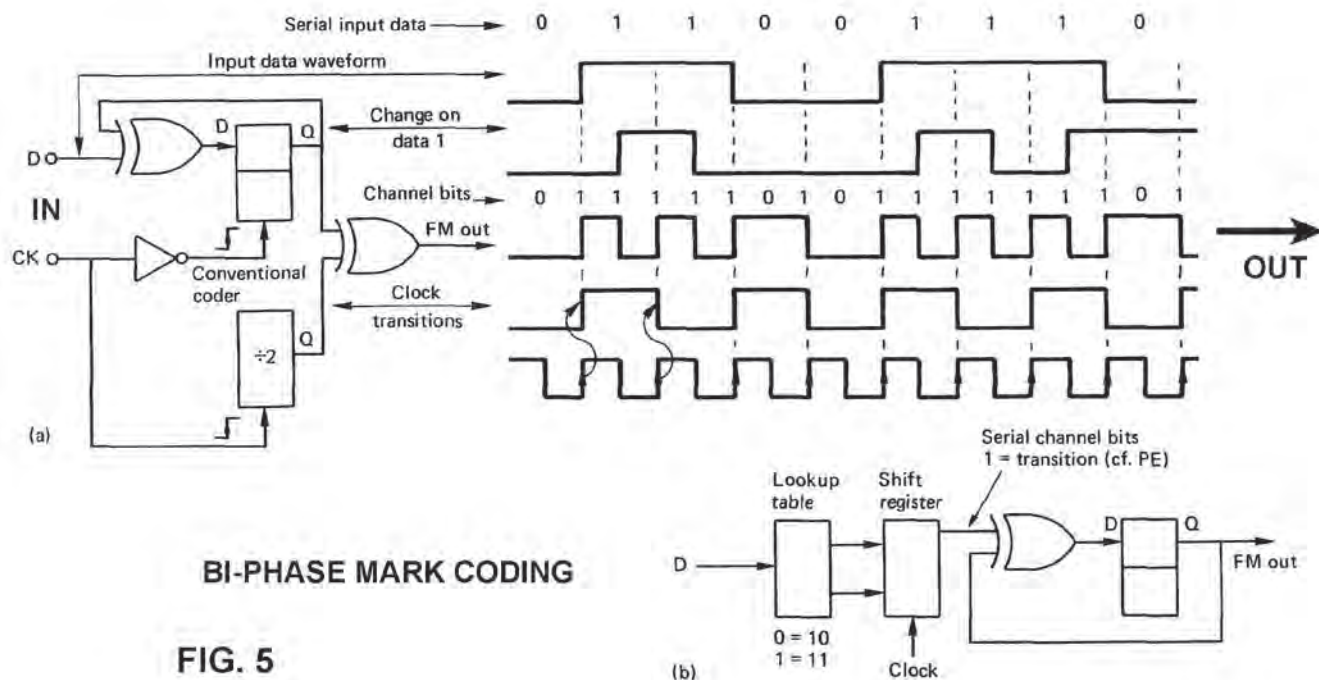

Conclusion

This has been a very broad-brush look at embedding and de-embedding. It provides a simple to use way of distributing uncompressed video and associated audio around production facilities. For compressed video, the various versions of MPEG do a similar job. Even analogue video with audio on a 6 MHz FM carrier has a similar aim. We can buy 2.4GHz systems for use around the home for very little money. However maintaining broadcast quality is a relatively complex and expensive exercise.

Further information can be obtained from the Gnum website:-
www.Gnum.com.

And from the EBU website:-
www.ebu.ch

Or put AES/EBU specification into Google. "Digital Interface Handbook" by Francis Rumsey and John Watkinson, Focal Press, 3rd Ed. 2004 contains a lot of useful information about digital systems generally.

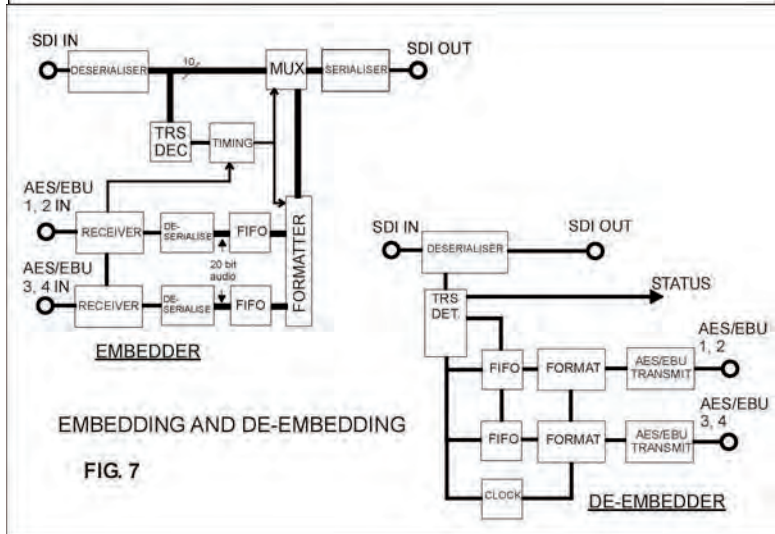
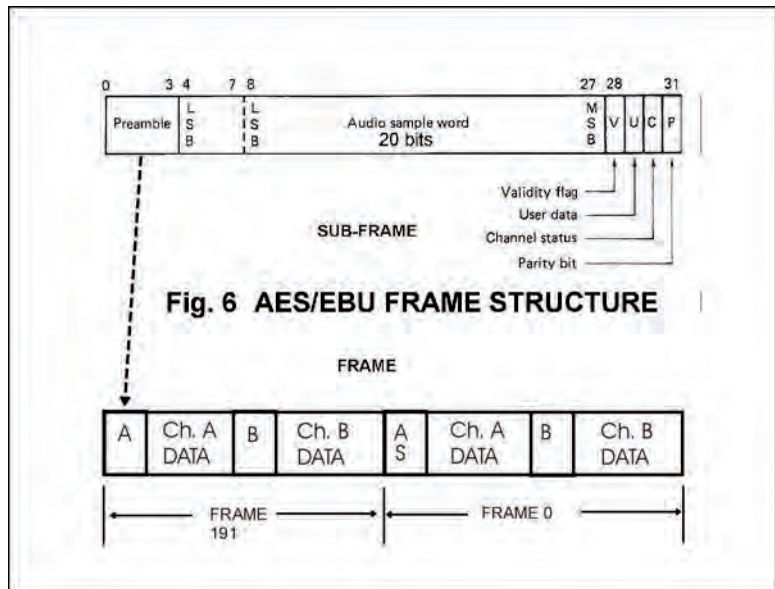

Gennum calls "last orders" on certain analog parts

by Mike Cox

DT Electronics have informed us that Gennum is to stop production of certain analog video parts from April 2007, and anyone who needs any of these parts should get their orders in quickly.

I have used these parts over the years, and one at least figured in a CQ-TV article in the last year. [CQ-TV 214, p6, NOAH ARC, GB4551 buffers to ADCs]

The particular parts that concern us are the **GB4551**, clamped buffer; the **GT4123**, two input multiplier; and the **GX434**, 4 x 1 crosspoint switch. Brian Summers should be aware that the 4

input component mixers he collected from me last are stuffed of these three devices.

They are particularly useful devices, particularly the GT4123 for use in keyers, and the GB4551 as the clamped buffer driving them.

DT Electronics will supply you with Gennum parts, but they have a minimum order charge of £50. They can be found at :-

DT Electronics Ltd
 Eastwood Business Village
 COVENTRY CV3 2UB
 Ph. 024 7643 7400
www.dtelectronics.com

This is an unfortunate consequence of the change from analog to digital technology. Manufacturers are finding that demand for analog chips is dropping below the level at which it is economic to make them. Consequently, many of the "industry standard" chips are now becoming like hen's teeth.

The only advice is to stock up while you can.

Autocycler For The Teletext Video Generator

by Michael Sheffield. ZL1ABS
zllabs@nzart.org.nz

The G8CJS colour video generator in the B.A.T.C. ATV Compendium Handbook featured EPROM (types 2716 or 2764) storage of pages of text and graphics using the Teletext display format. Amateur Radio information such as Club meeting nights, web page addresses for the National association, interesting graphic pictures (Ham Shack), AMSAT details, callsign Ids, local FM Voice repeater frequencies, and test cards are placed in the EPROM.

By using, now available, larger capacity EPROMs many more pages are possible with this generator for

use in the ATV station at home, public events or portable for Contests.

The high order address lines of the EPROM (A11 & A12 etc) can be wired out to a BCD thumbwheel switch if desired. However this circuit is offered as a solution with the facility for automatically cycling the EPROM through all the stored pages. It has application for a video beacon in an ATV repeater station or a public event display.

A 555 timer is configured as a slow oscillator to drive a 4040 binary counter. The 10uF timing capacitor may be adjusted in value to make the page turning faster or slower. To have a "stop" facility, pin 4 of the 555 timer may be connect to the plus 5 Volts

supply via a one kilohm resistor, so pin 4 can be grounded by a switch.

The 4040 binary counter connects to the high order EPROM address lines in the way:
Pin 4 Q7 A11 (2764 & bigger)
Pin 13 Q8 A12 (2764 & bigger)
Pin 12 Q9 A13 (27128 & bigger)

Pin 14 Q10 A14 (27256 & bigger)

Pin 15 Q11 A15 (27512 & bigger)

The MK3 PCB for the G8CJS Teletext Video generator has this Autocycler circuit included on the board for greater efficiency. Previous PCBs by Wayne Griffin ZL1UJK and the B.A.T.C Members Services PCB used this external Autocycler board.

Teletext pattern generator ver 3 G8CJS

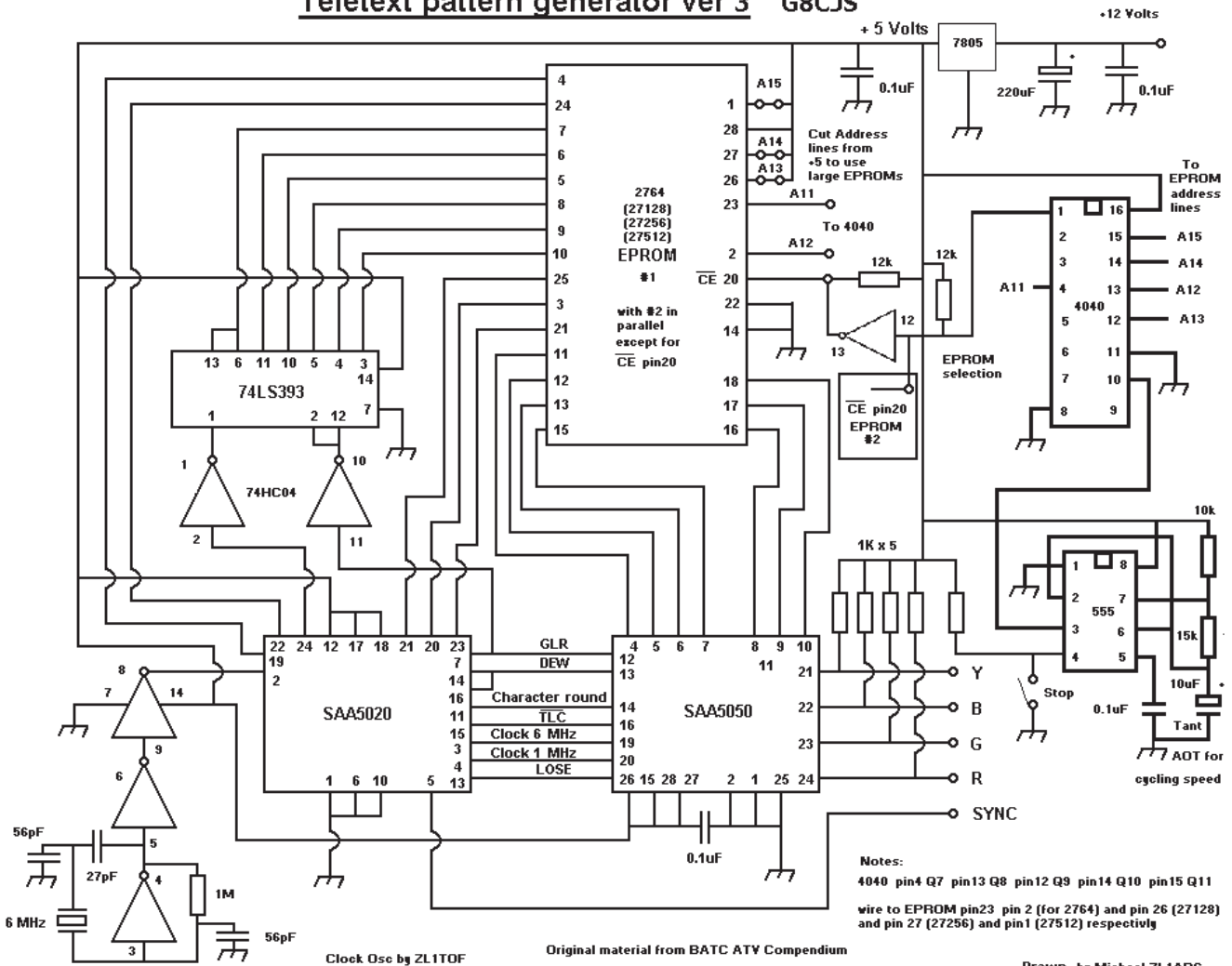

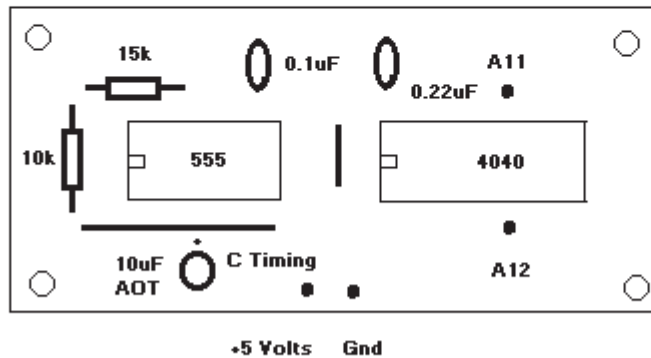

Book Review

by Andrew Emmerson

Here's a book I can recommend without hesitation; it's called *Television Innovations: 50 Technological Developments*. Dicky Howett is the author and his new book a large 128-page paperback published at £14.95 by Kelly Books.

Considering the number of words written on the subject of television technology, you might think it hard to come up with anything new. I myself have read far too many books on television, many of them poor or indifferent, to the extent that I didn't believe anybody could write something genuinely new and worth printing. Fortunately Howett's book manages this brilliantly and even better, it is jargon-free and readable.

I love the book: it is informative, honest, amusing and different enough to make it highly recommendable. The illustrations are not the hackneyed publicity shots that one has seen a hundred times before; instead they are either specially taken or resurrected from long-forgotten publications from days gone by.

The approach is sufficiently individual to make it can't-put-down-able.

Obviously there's no way you can condense the entire technology of television into a single book, particularly if you want to keep it 'accessible'. Howett doesn't try this; instead he has wisely gone for a selection and a good selection too. Whilst written from a British perspective, the book is not Anglo-centric, and presents a genuinely global view of television development.

Finally, however, it's the 'eye candy' or pictures that give this book the edge. If you get a warm feeling from looking at massive TV cameras that look the part, not like consumer toys, lavish studio scenes and lumbering old outside broadcast vans, this is the book for you. You won't find it in many shops but you can order it instantly through the publisher's website (www.kellybooks.net).

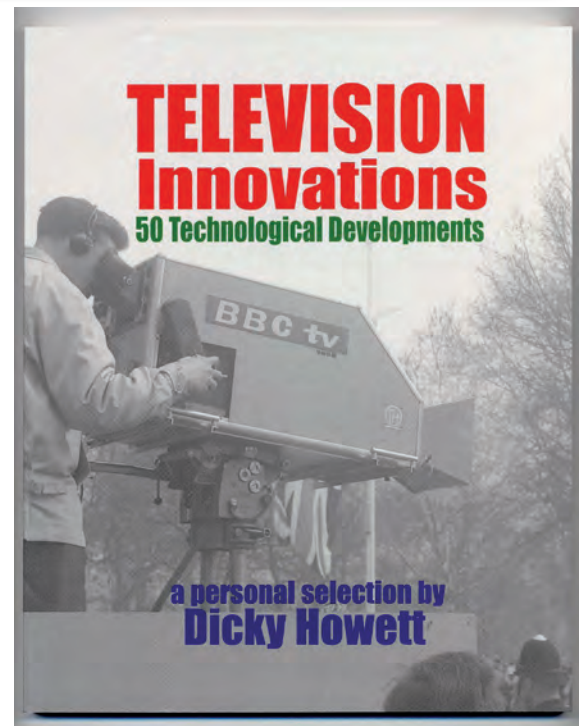

Dicky Howett
GOLDEN AGE TV
Phone
+44 (0) 1371 820155
www.golden-agetv.co.uk

September International Contest Results

CONTEST NEWS

Thanks to Richard, G7MFO, for calculating the UK Results for the September 2006 International Contest:

Place	Callsign	70cm	23cm	13cm	3cm	Total
1	G8GKQ/P	168	2592	3225		5985
2	G6TVP/P	186	864	2790	45	3885
3	G7ATV/P		1876	1325		3201
4	GW4NOS/P		768	745		1513

The results for each band were:

70 cm							
Place	Callsign	Score	Locator	QSO	Best DX	DX Locator	Km
1	G6TVP/P	186	IO93VI	2	G8GKQ/P	IO91RU	168
2	G8GKQ/P	168	IO91RU	1	G6TVP/P	IO93VI	168
23cm							
Place	Callsign	Score	Locator	QSO	Best DX	DX Locator	Km
1	G8GKQ/P	2592	IO91RU	6	M0DTS/P	IO94LI	280
2	G7ATV/P	1876	IO81QG	8	G8GKQ/P	IO91RU	158
3	G6TVP/P	864	IO93VI	3	G8GKQ/P	IO91RU	168
4	GW4NOS/P	768	IO81FP	3	G7FEQ	IO81RK	86
13cm							
Place	Callsign	Score	Locator	QSO	Best DX	DX Locator	Km
1	G8GKQ/P	2592	IO91RU	6	M0DTS/P	IO94LI	280
2	G7ATV/P	1876	IO81QG	8	G8GKQ/P	IO91RU	158
3	G6TVP/P	864	IO93VI	3	G8GKQ/P	IO91RU	168
4	GW4NOS/P	768	IO81FP	3	G7FEQ	IO81RK	86
3cm							
Place	Callsign	Score	Locator	QSO	Best DX	DX Locator	Km
1	G6TVP/P	45	IO93VI	1	G8KBC	IO93VK	45

The International Results can be found on-line at http://www.uba.be/vhf/atv/res_pop_atv2006_iaru.html. I hope that next year the UK can contribute more than 4 out of the 50 or so European entries.

I must congratulate Dave, G8ADM, on providing most of the equipment for the winning UK entry and thank him for allowing me to use my callsign! Also thanks to all the stations who made the effort to get out portable.

Contest Calendar

The following contests are planned for 2007:

24/25 March 2007 – ATV Repeater Contest

9/10 June 2007 – Summer Fun

8/9 September 2007 – IARU Region 1 Contest

All contests 1800 UTC Saturday until 1200 UTC Sunday

ATV Repeater Contest - Rules

As mentioned in the last CQ-TV, I plan to run a repeater-based contest in March to promote activity. I have thought long and hard about how to manage the scoring, and come to the conclusion that no system is perfect, but the simplest would be to score on the basis of the total RF distance.

So, for a two way contact on 23 cm (4 points/km), if you live 25km from the repeater, and the other station lives 10 km from the repeater, the score is 140 $((10 + 25) \times 4)$. A single-way contact would only score half; contacts using different bands in and out to the repeater should use the appropriate multiplier for each leg.

All transmitting stations need to do is transmit a four number group with their callsign. These should preferably be on the same screen, so viewers know who the numbers belong to. I recognise that voice contact to pass reports might not be practical, so if you see someone's callsign and their numbers, write it down. You can sort locators later! For the logs, all I really need is: time, callsign, numbers received, repeater used and points claimed

There is the potential for a listener to win the contest if he lives 75 km from the repeater and just watches and submits a log! I don't mind – it will stimulate activity. Note that I am prepared to accept logs from listeners watching the internet feeds from some repeaters, but please don't try to claim the internet distance, just the RF distance.

Contacting Me

I am about to move to Rome to attend a course at the NATO Defense College for 6 months. This has been long-planned and I intend to stay on as Contest Manager. I can be contacted by e-mail at contests@batc.org.uk, or by post to:

Wg Cdr D G Crump, Senior Course 110, NATO Defense College, BFPO 65, London

Please do not mention Rome in the address; BFPO mail goes to London and is distributed from there. I also hope to get Skype up and running – a search on my callsign should find me.

Last word – Please try to participate in the Repeater Contest; I will also be running a league table of repeaters.

ATV REPEATER CONTEST RULES

Contest sections

The contest will comprise two sections on each UHF/Microwave band on which ATV transmissions are authorized:

Section 1 - Transmitting:

This section is entered by all those who use transmitting equipment to send pictures for the purpose of establishing two-way vision communication, or those transmitting any other mode for the purpose of establishing one-way vision communication with a transmitting television station.

Section 2 - Receiving:

This section is entered by all those who use receive-only television equipment and do not attempt to communicate in any way with other participating television stations in order to influence their operations.

Duration of contest

The contest will commence at 1800 UTC on Saturday 24 March 2007 and will end at 1200 UTC on Sunday 25 March 2007.

Contacts

For contest scoring purposes a participating station may be worked or viewed only **once** through each repeater.

Contest exchanges

The following information shall be exchanged during a contact:

1. A Codenumber

For each repeater used a transmitting station shall choose a four-figure code group that shall not change throughout the contest. The four figures shall neither be the same (e.g. 2222) nor consecutive (e.g. 4567 or 5432). Stations using such groups shall be disqualified.

THIS CODE GROUP SHALL BE EXCHANGED IN VIDEO ONLY AND SHALL NOT BE TRANSMITTED BY ANY OTHER MODE THAN VISION.

On different repeaters a different code group - obeying the above rules - must be used.

2. Call sign (also in video)

3. Optional:

- Vision and sound report
- IARU Locator (also in video)
- Contact serial number, starting with 001 on each band used and increasing by one for each successive contact on that band

For the vision report the codes P0 to P5 shall be used:

P0 - No picture perceived

P1 - Synchronisation with very little picture contents

P2 - Only large images (callsign etc.) perceivable

P3 - Picture noisy but some detail resolved

P4 - Picture slightly noisy but with good detail and resolution

P5 - Noise-free picture

The report (e.g. P4) is followed by the suffix 'C' if the transmission is received in colour.

Scoring

Section 1:

A two-way exchange of the four-digit code group by vision shall score:

for contacts on the 435 MHz band : 2 points/kilometre

for contacts on the 1.3 GHz band : 4 points/kilometre

for contacts on higher bands : 10 points/kilometre

If only one station received the four-digit code group, the scores for *both* stations shall be reduced by 50%.

Section 2:

Reception of the four-digit code group by vision shall score:

for reception on the 435 MHz band : 1 points/kilometre

for reception on the 1.3 GHz band : 2 points/kilometre

for reception on higher bands : 5 points/kilometre

Notes.

i) For scoring purposes all valid contacts shall be deemed to have taken place over a distance of at least 5 kilometres, even if the two stations in contact have the same or adjacent IARU Locators.

ii) In order to make contest scores comparable, for the conversion from degrees to kilometres a factor of 111.2 should be used when calculating distances greater than the 5 kilometres mentioned under i) with the aid of the spherical geometry equation (Noordwijkerhout, 1987).

Entries

Entries should be submitted by e-mail or posted to the Contest Manager not later than the third Monday following the contest weekend. Late entries will not be accepted. The submission of the logs implies that the entrant accepts the contest rules.

Judging of entries

The judging of the entries shall be the responsibility of the Contest Manager, whose decision shall be final. Entrants deliberately contravening any of these rules or flagrantly disregarding the IARU Region I bandplans shall be disqualified. Minor errors may result in loss of points.

The claimed contact will be disqualified for an obviously wrongly stated Locator, callsign, codenumber, or a time error of more than 10 minutes.

Logsheets

The logsheets used shall show the following columns in the order named:

- date
- time in UTC
- callsign of the station worked/seen
- report sent: P# report followed by serial number (section 1 only)
- report received: code number (vision!) followed by P# report and serial number
- IARU Locator received
- Repeater Callsign
- number of points claimed

A standard cover sheet, containing the following information should be submitted:

- name, address and station call sign
- station IARU Locator
- repeaters used, with the four-digit code group used for each repeater
- claimed score

It is hoped to publish a suitable Excel Spreadsheet on the BATC WebSite.

Adding 3cm to the GB3BH repeater.

by Dave Mann. G8ADM

Contact:
g8adm@gb3bh.com

When I was a lad the technology required for the 3cm band was completely different to the VHF/UHF bands and most amateurs found it too much of a challenge to contemplate operating on the microwave bands.

Receivers consisted of germanium diode mixers with klystron tube or later Gunn diode local oscillators, waveguide mounted, achieving noise figures of around 10dB.

Transmitters also used klystron tubes or Gunn diodes for low power or bigger klystrons or Travelling Wave tubes requiring complex high voltage power supplies for high power.

Nowadays it's much easier. Relatively conventional receiving circuits using surface mount FET pre-amps and mixers can achieve noise figures of less than 0.5dB at very low prices.

FET's are also available for transmitting, capable of generating hundreds of watts if required using 12V power supplies. These however are quite expensive.

So having received the NOV to add 10GHz to the existing 13cm GB3BH repeater it was a relatively simple job to assemble the various parts. Fig 1. shows the system block diagram. We used commercially available parts where possible to reduce the construction time.

The transmitter consists of a temperature-stabilised and frequency-modulated FET DRO and amplifier providing 1W of RF and a 25W FET PA, both purchased from *Kuhne Electronics*. The video and audio drive electronics were home made.

The receiver uses a 5 pole bandpass filter from *micro-mechanic* and a modified satellite LNB from *Bob Platts* feeding a professional satellite receiver.

The antenna, a dual 16 slot waveguide, was also home made with the help of Tony's (G1HBD's) milling facilities, shown being aligned in Fig 4.

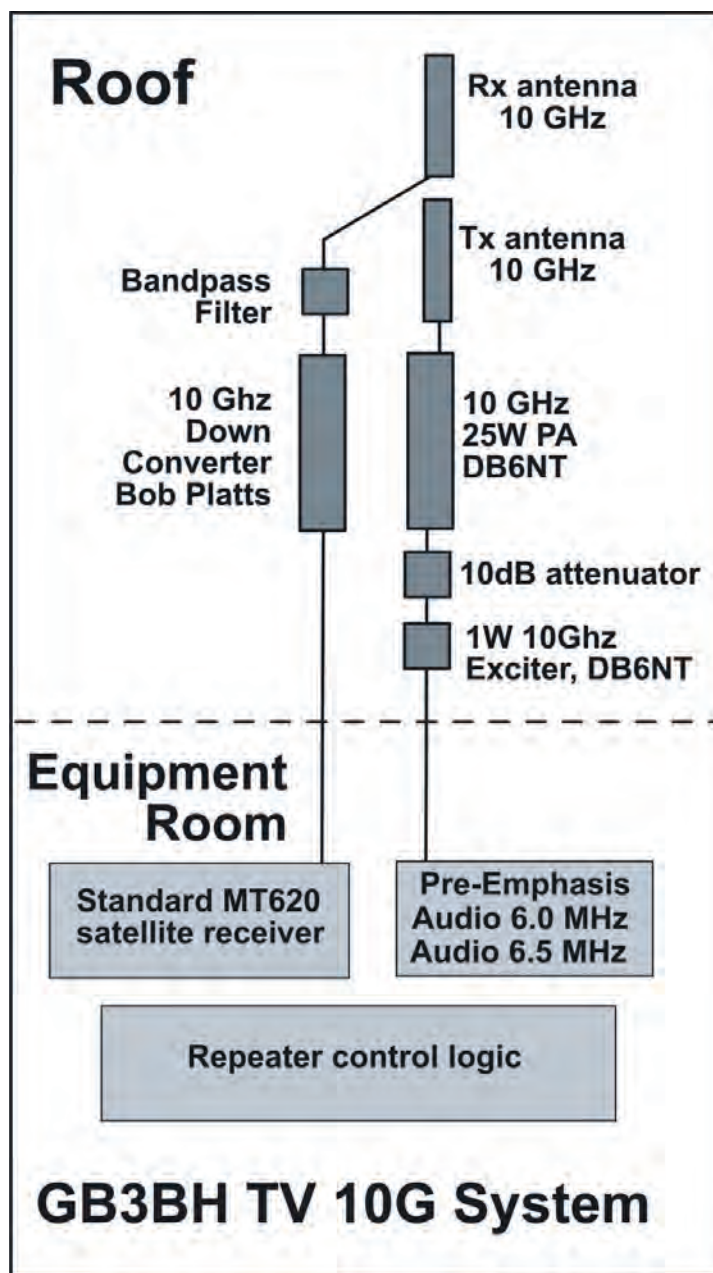

fig.1

All the above was built into a waterproof case and mounted on the church tower alongside the already present 13cm equipment. See Fig. 2 and 3.

The antenna has a gain of 10dB, which provides a relatively high ERP from the 25W PA. To date we have received P5 reports from Luton at 20 miles, from Heathrow at 10 miles, and from The Hogs Back at 30 miles, all using simple horn receive antennas. Many stations in the local area receive P5 pictures using just an LNB without a dish.

The big advantage of 3cm over 13cm is that there is absolutely no interference. On 13cm we are plagued with WiFi, cctv and other sources of RF that disrupt the signal.

I hope the above will encourage you to try 3cms. If you have any questions about our repeater, or if you can receive it and you wish to send a report, please contact me at my e-mail address above.

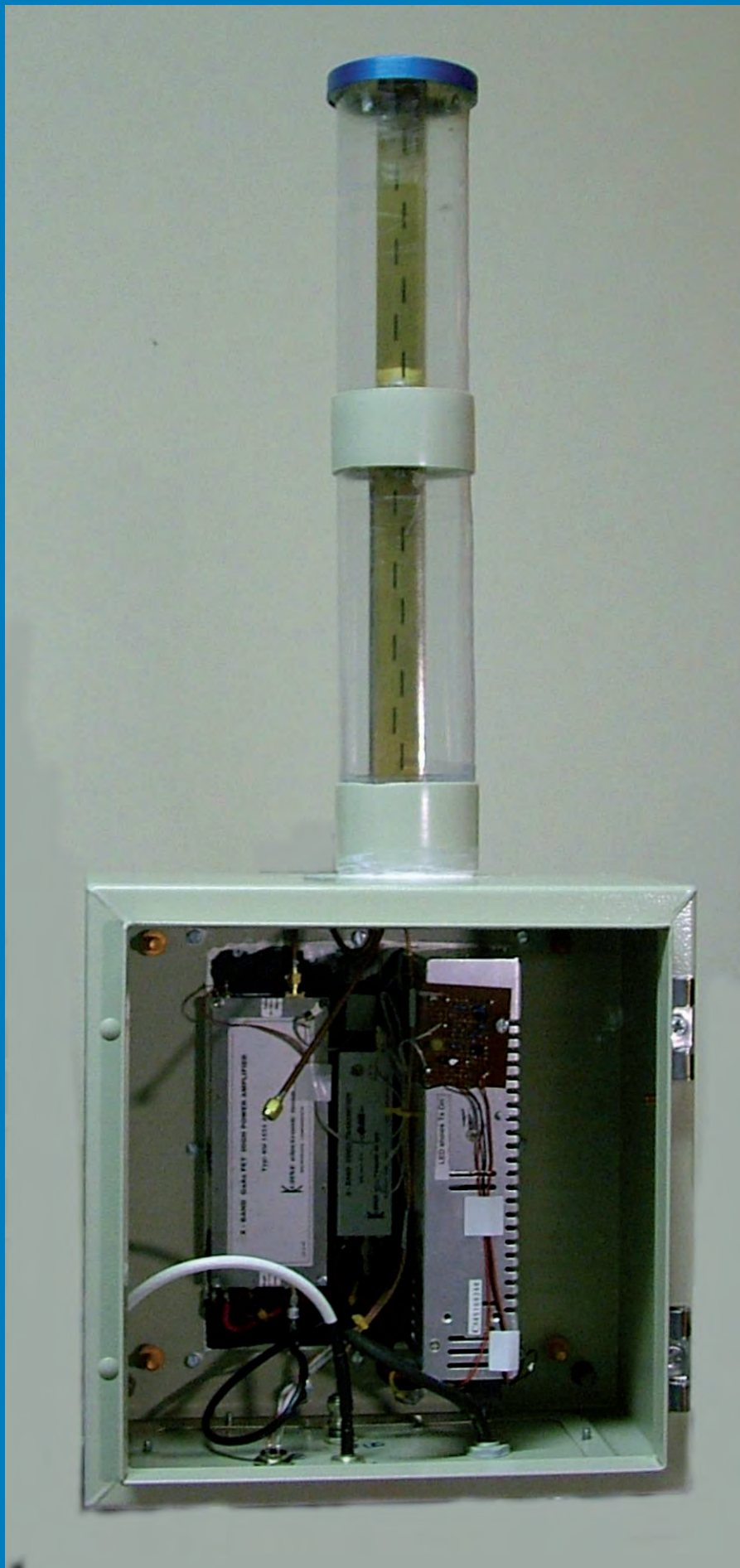

fig.2

Repeater Specification:

Callsign GB3BH

Location: South Hertfordshire,
UK, IO91TP

Transmit: 2,440 and 10,065
MHz, 100w ERP on both bands.

Receive: 2,340 and 10,315 MHz
Modulation: Analogue FM

References:

Kuhne Electronics
<http://www.db6nt.de>

micro – mechanic
<http://micro-mechanik.de>

Bob Platts
see adverts in CQTV

Web Site
<http://www.gb3bh.com>

Internet Video:
<http://gb3hv.camstreams.com/>

(Streams GB3BH when GB3HV
is off)



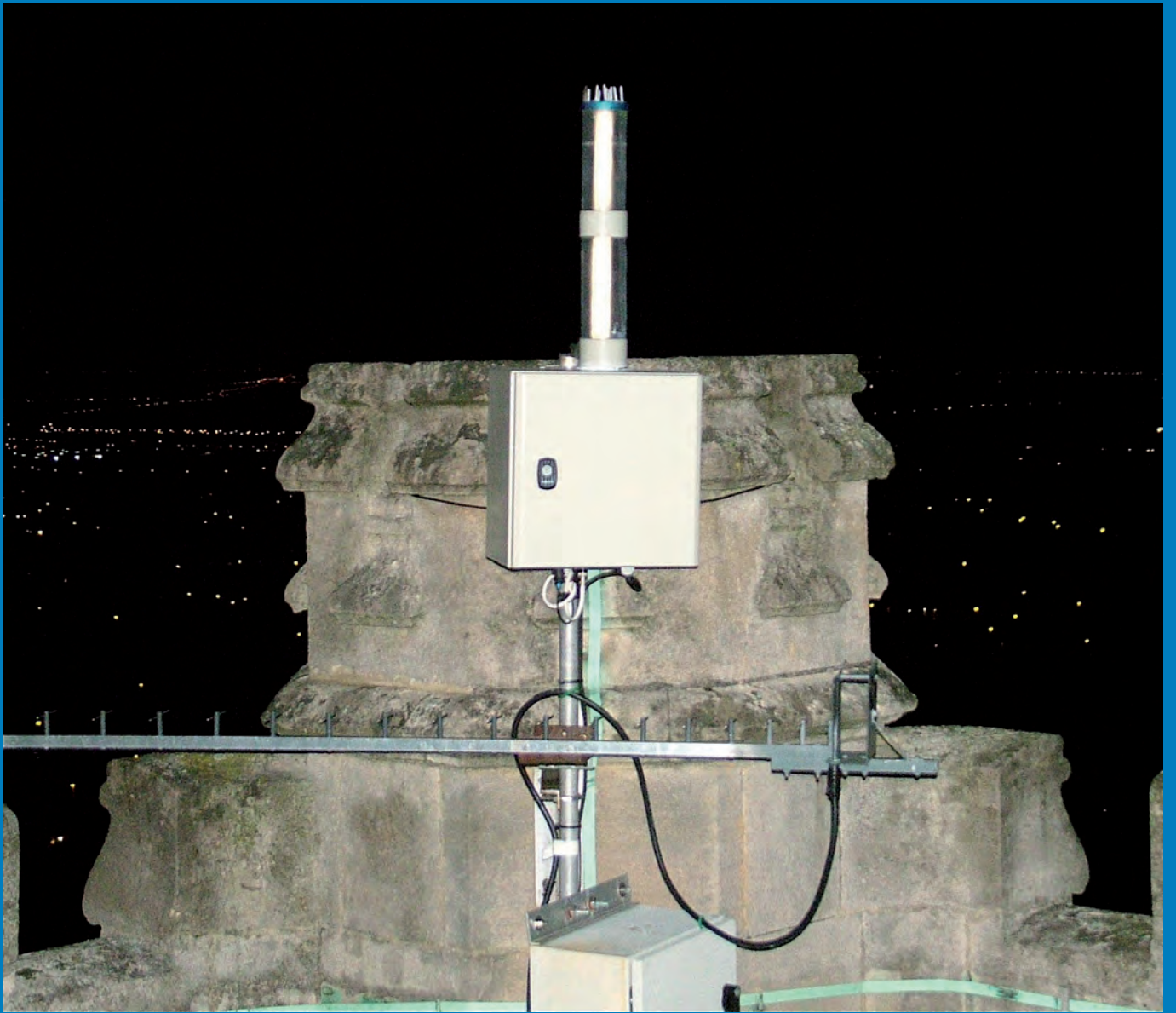

Above: fig.3



Left: fig. 4