

CQ-TV



No. 161

February 1993

The Mk.2 BATC

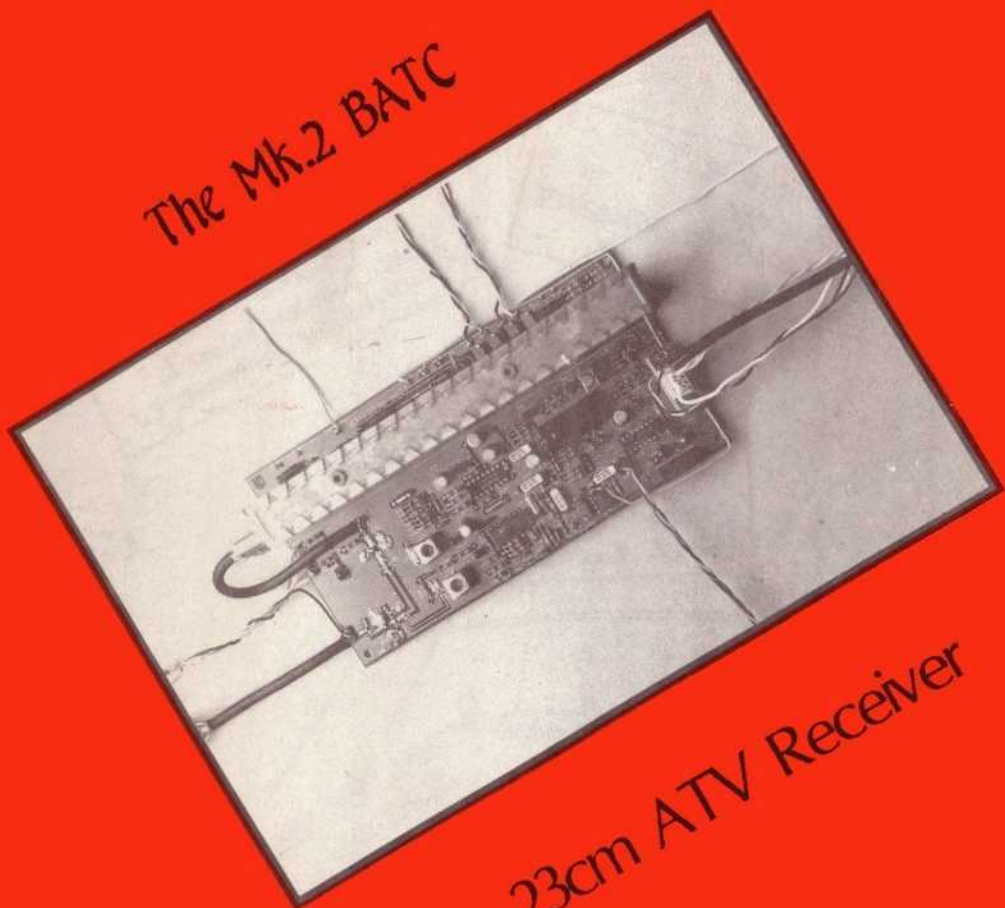

23cm ATV Receiver

BRITISH AMATEUR TELEVISION CLUB

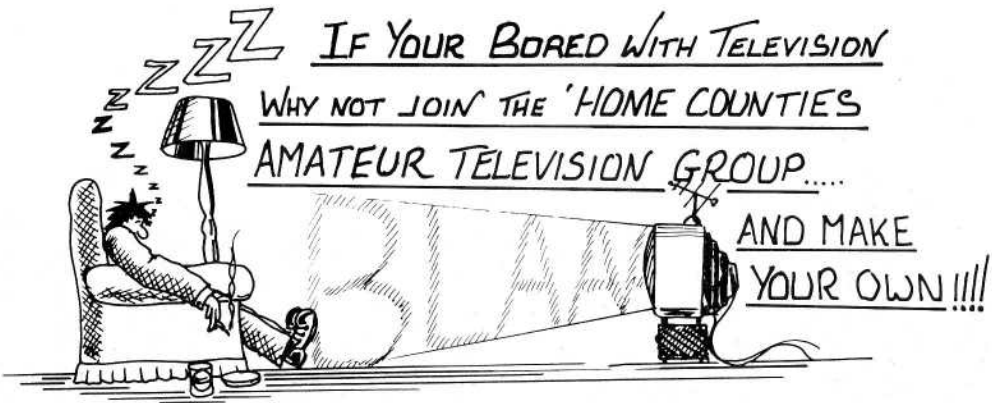

IN OUR GROUP WE.....

DEMONSTRATE AMATEUR T.V.
TO THE PUBLIC AT
COUNTY SHOWS/GOLF TOURNAMENTS
CAR RALLIES ETC....

GROUP MEETINGS EVERY
MONTH.
DISCUSSING HOME
VIDEO, TRANSMISSION &
RECEPTION OF AMATEUR T.V.

RUN & MAINTAIN A MICROWAVE
T.V. RELAY AT HIGH WYCOMBE
COVERING BERKS - WEST HANTS
SURRY - SOUTH & WEST LONDON.

NEWSLETTERS.

PORTABLE WALK-ABOUT
STATION.



CONTENTS

- | | | |
|----|---|------------------------|
| 9 | The BATC 23cm ATV Receiver Mk.2 | Bob Robson GW8AGI |
| 21 | An Insert Generator | Hans Wessels PA2HWG |
| 24 | ADV is Here! (Well, Almost...) | Andy Emmerson G8PTH |
| 27 | Lighting ATV Part-2 | Norman Ash G7ASH |
| 32 | Modifications to the Amstrad
Computer Modulator Converter MP-3 | M.R.Perry G8AKX |
| 35 | Auto SCART Switching Your TV | John Stockley G8MNY |
| 36 | Satellite TV News | Paul Holland G3TZO |
| 43 | The Club's New SSTV Book <i>Review</i> | Pam Penlington GW0LAL |
| 45 | HDTV the Leo Zucker Way | Trevor Brown G8CJS |
| 51 | A Beginners Guide to SSTV | Pam Penlington GW0LAL |
| 62 | More on Modifying BSB Receivers | Trevor Brown G8CJS |
| 68 | Home Counties Group Strikes Again !! | John Bales |
| 70 | TV on the Air | Andy Emmerson G8PTH |
| 74 | How to Construct Inductors | John Cronk GW3MEO |
| 75 | TH2SAT Weathersat System <i>Review</i> | Mike Wooding G6IQM |
| 80 | Computer Assisted SSTV | Jamie Powers G0JNK |
| 83 | Waveguide Transitions | Anthony Horsfall G4CBW |
| 84 | Slaving the ZNA234 | Bryan Dandy G4YPB |

CLOSE FOR PRESS FOR THE NEXT ISSUE 1st MARCH 1993

**CQ-TV is produced on a 386 PC computer system, using the PROTEXT word processing package and the TIMEWORKS desktop publishing package.
The camera-ready artwork is produced on an OKI OL400 Laser printer.**

The magazine is printed and bound by APEX PRINTERS of Rugby.

POST

THANKS

Dear Mr. Wooding,

Last weekend (late November) I had a query regarding the suitability of a certain commercial BSB satellite receiver being able to be converted to our amateur use.

I phoned Mr. Andy Emmerson, who was very polite and helpful, and he put me in touch with Trevor Brown.

Mr. Brown gave me useful advice and steered me in the right direction.

Thank you very much, Mr. Emmerson G8PTH and Mr. Trevor Brown G8CJS. Makes being a member of the BATC worthwhile doesn't it?

Yours ... Tom Rudderham G7HJR

That's what we're here for Tom, glad we could help ... Mike

23cm ATV REPEATER FOR DERBY ?

Dear Mike,

As a member of the BATC for the past twelve years or so, I have been active periodically on ATV on 70cm, but never on 23cm, mainly since from my home location (12k NW of Derby) it is not possible to access any of the existing ATV repeaters.

Through my business I own a PMR mast and associated equipment building on a hill (Drum Hill) just a few kilometres

north of Derby. Although I do not have the time to get involved in building a 23cm ATV repeater, I could provide the location and facilities for a group to build, install and get licenced an ATV repeater. I would expect the coverage from this location to cover all of the Derby area, and be accessible in the west of Nottinghamshire, the north of Leicestershire and the east of Staffordshire. Therefore, it would nicely fill a geographic gap that exists. Naturally, any repeater would need to coexist with my existing commercial users and not cause ant interference, etc.!!

If anyone would like to take me up on this offer, then perhaps they can contact me during working hours at Evets Communications Limited, on Derby (0332) 363981. The same offer exists for anyone who would like to have a 10 GHz and/or 24 GHz beacon in the area.

73 ... Steve Haseldine G8EBM

Many thanks for your kind offer Steve, I have no doubt that you will be contacted. Incidentally, ATV life exists on 24cm outside repeaters! ... Mike

NGS DESIGNS

Dear Mike,

Stuart McGillcrist suggested that I drop you a line. We have been working on BSB conversions since about last February. We formed a team of very experienced people; software, hardware and mechanical design.

The first receiver we worked on was the Ferguson. We have a Mk.I board which we demonstrated at radio rallies in April.

This module gave flicker-free pictures and good sound. Because the people we chose to do the software were very keen on satellites the D2MAC software was partially written before we met up with them. This then gave us the Mk.I board with PAL/D2MAC and manual switching for PAL/D2MAC and polarisation.

The cost of the Mk.I board is £18.00 and the software £8.50.

We now have a Mk.II board. This gives sound on Astra, Eutelsat and 8 audio channels. Software controls the audio channels, PAL and D2MAC. Polarisation is automatic.

From the remote the only thing we have managed to do are the on-screen menus, but this is only time and a software change. The cost of the Mk.II board is £32.00 including software. Fitting, if required, is £12.00 extra, but preferably in multiples, as 1-offs are hard work!

Tatung (Decca) software is still incomplete, but can be manually tuned - board £18.00. Philips software is still on-going. All units when complete will be as the Ferguson and will operate from remote.

All the above receivers could be used as a second receiver, in the kid's room. You can tee off an Astra dish with a capacitor, or use your BSB dish with our D2MAC/PAL EPROM for receiving French or German stations, or we can convert your BSB dish and receiver to work on the complete Astra band - £10.00.

Here's to good viewing on BSB to Astra systems. Contact MGS Designs on 0332 47795 or 0602 321248.

REFERRING TO 'AMIGA BITS AND PIECES', CQ-TV 158

Dear Mike,

As part of the growing ATV community around the 'Multimedia Repeater' DB0KO in Cologne, Germany, I would like to introduce to you, dear readers, the use of Amiga computers amongst us.

Like me, some operators are working with a 500 and additional parts, such as Genlock, digitisers for video camera pictures, fax and SSTV modems, hard disc for quick picture display performance and so on. All the modes of the repeater (ATV, SSTV, FAX, RTTY METEOSAT) can be accomplished with the help of an Amiga. But, on top of us all is Max DB1KZ, who owns two Amigas, one equipped with a Turbo card (68040) and a Sirius Genlock, with various options in a superb quality.

Having done some painting years ago in his free time, Max is now our 'Master of Digital Art'. As he has retired he spends some hours nearly every day creating nice pictures and animation sequences with 'Deluxe Paint 4'. So, he was chosen to produce the opening titles for the new ATV bulletin, which is broadcast on DB0KO every Sunday morning (since September 1992). Coloured text pages scroll over a graphics background like a rotating globe, or some digitised photographs of repeater views (the repeater is located on top of the tall SW radio station 'Deutsche Welle' building).

After the opening screens a presenter, of course a Ham, reads the text of the weekly DARC bulletin, accompanied by inserts or related picture material, while

the call of the club station DL0KA is overlaid most of the time. At the end some videotape recordings of local Ham events or educational tapes show parts of radio amateur life to the hundreds of viewers, who are equipped with a simple 1.2 GHz downconverter in front of their TV set.

I nearly forgot to mention that the text of the bulletin is received via Packet radio with a 1200 or 9600 Baud modem and printed out - you got it - with the help of an Amiga!

73 Klaus DL4KCK

HELP PLEASE - BELL & HOWELL VTR INFORMATION REQUIRED

Dear Mike,

Forgive me for writing to you out of the blue, but I have been given your name and address by Andy Emmerson G8PTH regarding information on a Bell & Howell 2000 1" VTR (IVC 602). It seems that you are my last hope, perhaps you would kindly publish the following plea for help in the next issue of CQ-TV.

WANTED: Colour Processor board and/or circuit diagrams for the IVC 602 1" VTR (bell & Howell) or faulty machine for spares. W.H.Y. Contact: J.C.Alford MBKS, G4DOE. Tel: 06898 31878 home; 071 320 1218 office.

73 John G4DOE



NEWS

CQ-TV OFFICE MOVES !

For those of you who contact me regularly and used the Rugby number 561281 please note that we have now disposed of my Lady's shop and I have moved my office and the CQ-TV office back home - to the dining room again! So, please do not use the above number as you will only get number unobtainable. The ONLY telephone number for CQ-TV is 0788 890365. If you wish to fax any information to the magazine the number is 0788 891883.

73 Mike

GB3RT NEWS

R:921126/1144

81559@GB7RBY.#27.GBR.EU

[Rugby, Warwickshire] NNA V2.0

From :

G6WLM @ GB7RBY.#27.GBR.EU

Hello Mike trust you and family are well, are you ready for Xmas, Hi. Thanks for mag, enjoyed article on 13cms more boards to etch, Hi. There follows an extract from my Pms on RT to keep you in touch. I will leave it to you to edit for mag if you wish. But the main thing is she is up and running. 73s for now Steve.

UPDATE 24 NOV 92.

GB3RT was off air from 13 Nov to 17 Nov for a refitment of PA stage. The

Blue Brick was replaced, plus the 7809 bias regulator and two 100uF electrolytics these latter components had not failed but changed as a matter of course due to length of service. All ceramic capacitors were checked on output stage and appear to be working normally. The output power of the Blue Brick is rated at 15 Watts, but actual output power after the interdigital filter was aprox 10 to 12 Watts, I hasten to add this was measured with a homebrew power meter not accurate at 1318 MHz. (New one in construction, Hi).

Measurement of the output power will be checked in a few weeks time with a commercially available pwr meter. Giving time for reports. All Picture/Signal reports welcome.

I would like to close this update with a special thanks to John G1YFI and Vic G6EWZ for making the refit possible. Many thanks for reading this bulletin ... Steve G6WLM GB3RT manager.

8 WATTS OVER 8,000,000,000 KILOMETRES

An 8 Watt transmitter has been sending data back to Earth for over twenty years and is now 8 billion kilometres away (5,000,000,000,000 miles). The spacecraft Pioneer-10 was launched by an Atlas-Centaur rocket on March 2nd, 1972. Weighing only 260 kg, it headed for Jupiter with a life expectancy of 21 months. It is now envisioned to last on into the 21st century, because when it passed close to Jupiter (130,000 km) the planet's gravity propelled pioneer-10 toward the limits of our solar system.

When it crossed Neptune's orbit in 1983 that made it the first man-made object to leave the solar system. Scientists are calling it a great human technical miracle being able to receive intelligible data from a QRP transmitter over such a distance.

We will be hard pressed in the amateur ranks to better that record and thanks to NASA for proving that QRP is coming into style approaching the year 2000.

Thanks to Spectrum Magazine (NZARS VHF Group) for this snippet. It makes my attempts to swap pictures in the past with Barry G6IKQ, 16 or so miles away, seem pretty futile and small in the scheme of things ! ... Mike

BIRMINGHAM ATV REPEATER

Trials will be commencing soon from the headquarters of the Midland Amateur Radio Society in the jewellery quarter of Birmingham. This location is only temporary at present, but will allow equipment trials to proceed. For further information contact Graham G8EMX, QTHR.



THE OFFICERS OF THE CLUB
AND THE COMMITTEE WOULD
LIKE TO WISH YOU ALL A
BELATED HAPPY AND
PROSPEROUS 1993



**BATC
TELEPHONE
BULLETIN
BOARD**

NEW NUMBER

0933

413396

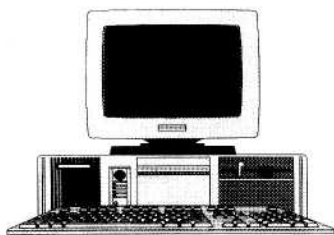

1993 VIDEO EVENTS DIARY

Compiled by **Brian Summers**
G8GQS, Hon. Treasurer

6th MARCH: BATC & Home counties ATV group at the VHF convention held at Sandown Park

13-14th MARCH: BATC at the London AR&C show held at Pickets Lock.

13-14th MARCH: Spring ATV contest

5-7th APRIL: "Cable & Satellite 93" Olympia 2 London.

2nd MAY: BATC annual rally and convention Harlaxton

8th MAY: "Narrow Bandwidth TV Association Exhibition". Details D. Pitt 0602 282896

16th MAY: BATC at the "RSGB national convention" at the NEC Birmingham

16th MAY: "National Vintage Communications fair" at the NEC Birmingham

13th JUNE: BATC at Elvaston Castle mobile radio rally

11-15th JUNE: "18th International Television Symposium and Exhibition". Mon-treux Switzerland.

26-27th JUNE: Home Counties ATV group at the "Middlesex County show". Live ATV demos. Details Mike 0420 563859

24-25th JULY: Home Counties ATV group at the Coombe Golf Club Kingston Hill. Live ATV LINKS?? Details Mike 0420 563859

SEPTEMBER: BATC at the Lincoln Hamfest (rally)

16-20th SEPTEMBER: "Live 93" domestic consumer equipment show at Olympia.

OCTOBER: BATC at the Hornsea rally
BATC at the Leicester Radio exhibition

29-31st OCTOBER: "Northern Video & HiFi Show Inc. What Satellite" at G-Mex Hall Manchester

NOVEMBER: Autumn ATV Contest

20-21st November: "Institute of Videography exhibition" at Trentham Gardens, Stoke on Trent. Details Ken Potter 0254 386659

DECEMBER: Winter ATV Contest

I hope that some of the events and dates above might be of interest to you, if so copy them off into your diary **NOW**.

Only brief details are given as full details will appear in other publications. Please check details before going for possible changes.

Pressure on space may not permit this list to appear again.

OYEZ! OYEZ!

**HEAR THIS YE GOOD
FOLK OF ATV LAND.**

**THE HONOURABLE
BRITISH AMATEUR
TELEVISION CLUB
SHALL BE HOLDING
THEIR 1993**

**CONVENTION AT
HARLAXTON MANOR
ON SUNDAY MAY 2nd
AT 10 OF THE
FORENOON**

**FULL DETAILS SHALL
BE MADE KNOWN IN
CQ-TV 162**

A CQ-TV PRODUCTION

The BATC 23cm ATV Receiver Mk.2

Bob Robson GW8AGI

INTRODUCTION

The new ATV handbook contains a design for a new receiver. This design was based on published data from ASTEC, as the prototype of the module only came to hand one week before publication date - too late to build a prototype receiver and debug the article for the handbook. Subsequently a prototype was built which worked (after bugs in PCB design removed) reasonably well, but did not take full advantage of the modules capabilities. The Mk.2 design, along with the printed circuit board, does. Both the ASTEC module and the Printed Circuit Board are available from Members' Services, please see the supplement enclosed with this issue.

The receiver is based on an ASTEC TVRO (AT2320) module designed for satellite reception, and tunes from 950 MHz to 1750 MHz (which happens to cover our 23 cm band), and has an acceptable sensitivity to go with it. The module has two RF inputs which are selected by a pin diode switch, and each input has its own filtered input pin to allow an LNB (Satellite down converter) to be fed power via the coaxial cable. There are four bandwidths for the IF within the module, along with two notch filter. These are all controlled externally allowing for a very flexible design. On the output side in addition to the recovered video, there is an AGC voltage, noise monitor voltage and a prescaled local oscillator signal.

RECEIVER SPECIFICATIONS

Tuning Range	950 - 1750 MHz
Sensitivity	-80 dBm with pre-amp
.....	-65 dBm TVRO direct
AGC Range	-65 to -15 dBm
Receiver Bandwidth	Switchable 36, 26, 20 and 14 MHz
Video Output	1 Volt PP into 75Ω
Audio output	500 mW into 8Ω
Audio IF	Tunable

CIRCUIT DESCRIPTION

The module is basically a complete FM superhet receiver in its own right in that it takes in a signal between 950 MHz and 1750 MHz and outputs any modulation that

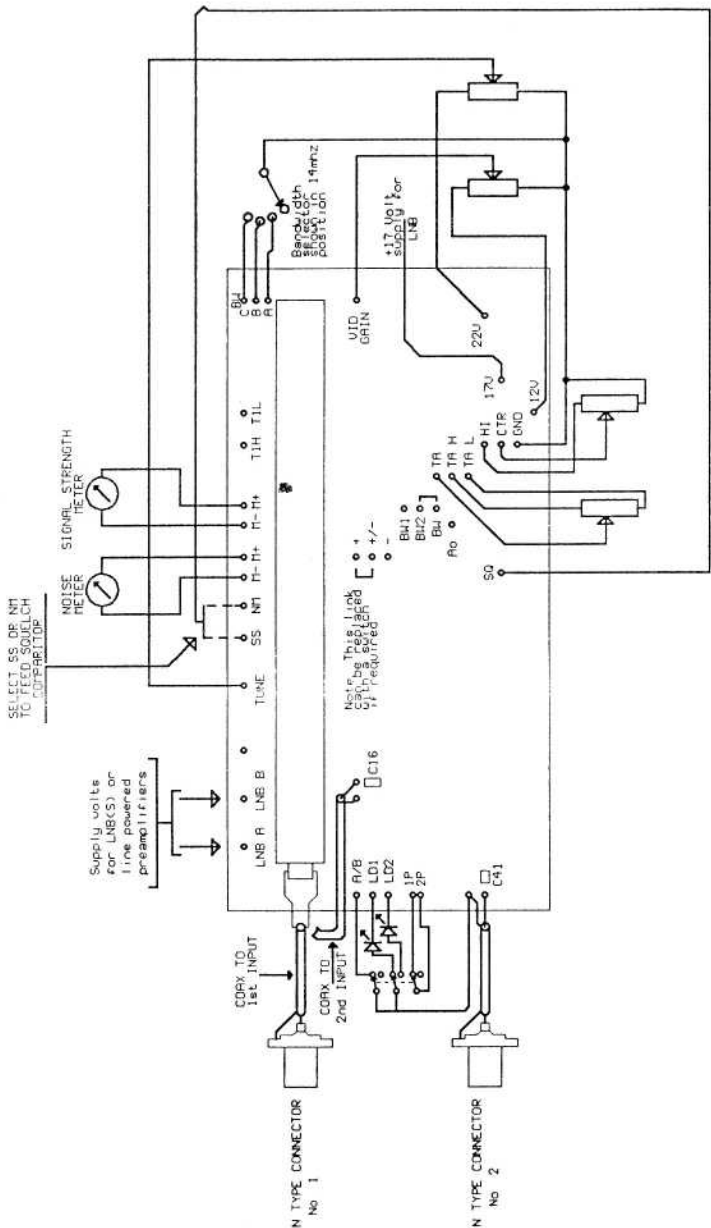

Fig.1: The Receive Module and the Interconnections to and from it

was on the signal. This particular module has several interesting and useful features:

- a: Two independent RF inputs, selected by pin diodes activated by an external switch, with terminals to allow a supply voltage to be sent up the coaxial cable to feed an LNB
- b: switchable bandwidth
- c: Noise level output. This can be used to drive a meter to give an indication of signal quality
- c: AGC voltage output for signal strength readings
- e: A notch filter which can be used to reduce interfering signals
- f: A prescaled output (LO divided by 128)

How have we used the module to obtain the best results ? Read on:

As the module is designed as a tunable IF for a satellite system the basic noise figure is only of the order of 8dB which is not good enough for our 23cm activity so a preamplifier is desirable to reduce this input noise figure and at the same time improve the sensitivity of the system.

On the circuit board is a two stage pre-amp consisting of a GaAsFET TR4 (AFT20135) which feeds a MMIC IC6 (MSA 0685) with all the s formed by the print. This combination gives a gain of approximately 24dB with a noise figure better than 2dB. There is only one capacitor to be tuned so setting up is simplicity itself. The preamplifier is fed from a zener stabilised supply which is fed via a link on the board. This is because it is advisable to remove the supply from the preamplifier when the alternative input to the tuner module is being used as the circuit can 'hoot' if the termination load is removed.

The module has two 'F' type connectors for the RF inputs. The required one is selected by applying either 12 volts or ground to the pin diode switching circuit pin 5. On the PCB pin-5 is pulled up to +12 volts so a switch to connect the pin to ground is all that is required.

Other circuits in the module controlled by external switching is the bandwidth. The bandwidths available are :- 36 MHz, 24 MHz, 18 MHz and 14 MHz. The three control pins have pull-up resistors and are arranged that with none connected to ground the bandwidth is 14 MHz which is normally used for ATV signals.

The demodulated video is present on pin-19 of the module, but is only 200 mV for a full bandwidth signal so two stages of amplification are used to give us the correct 1 volt peak to peak, 75Ω impedance we require. In addition we need to apply de-emphasis to the signal to remove the high frequency lift applied in a transmitter.

The output of the module feeds two points. One via C13 to the sound circuit, and the other via R12 to the de-emphasis network. At the output of the network there is a 6 MHz trap - L11 & C23 to remove any residual audio carrier on the video signal before

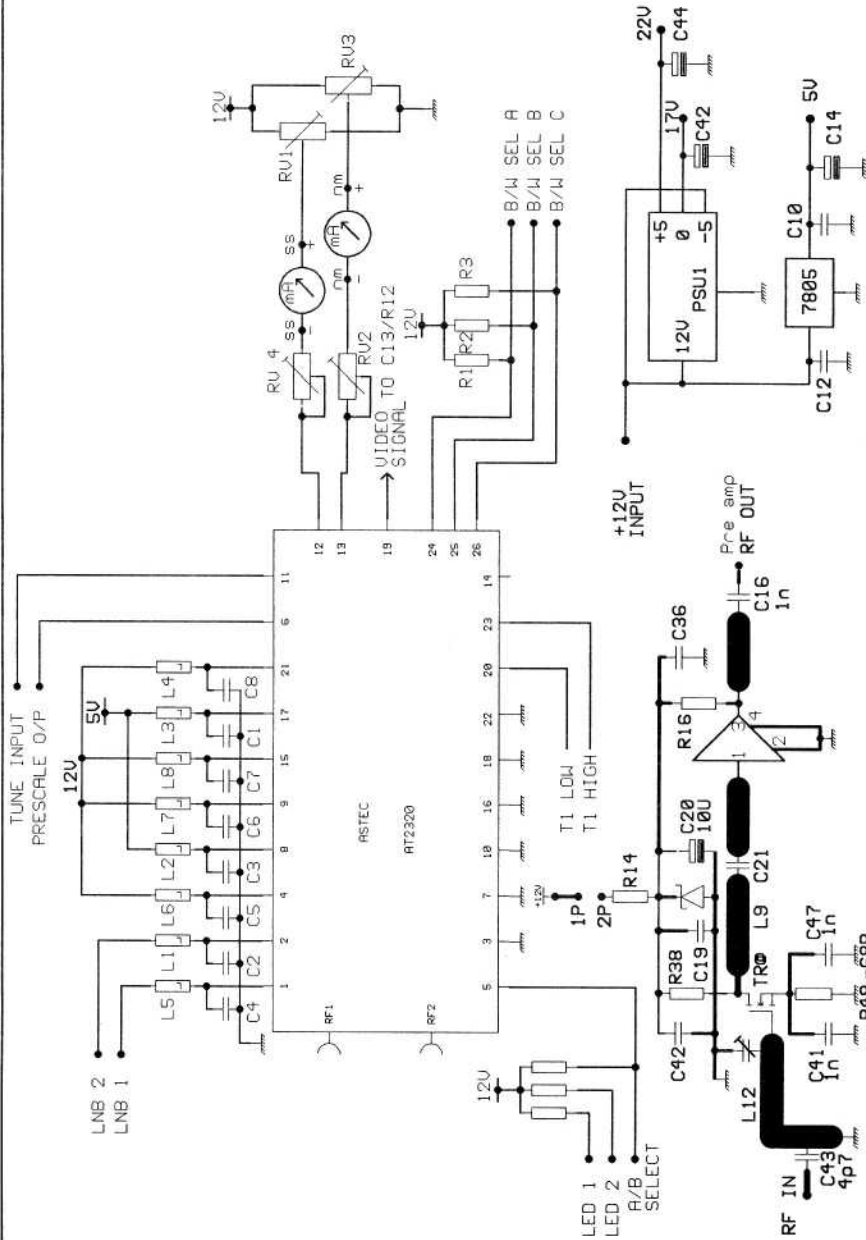

Fig.2: Circuit Diagram of the RF unit

it is fed into the first video amplifier IC2 (NE592). To compensate for received signals with less than ideal deviation a gain control is provided. This is a FET TR3 (2N3819) connected between pins-3 and 12 of IC2. All that is needed for control is a suitable potentiometer (10k) across the 12 volt supply to drive the gate of TR3 via R5.

The amplified video is fed to two pins to allow either positive or negative modulated signals to be selected for feeding to the input of the second video amplifier. The selected video is fed via a 100nF capacitor and a 220Ω resistor to the base of the input transistor. The bias for this stage is set by R18 (47k) and R25 (22k) and fed via D1. This acts as a sync tip clamp and holds the video at a constant level and removes any energy dispersal signal which can be found if a satellite signal is being received. (Don't forget that with a suitable LNB this receiver can be used for satellite reception).

The second video amplifier is set to a gain of two and has a low output impedance to allow a 75Ω resistor to be fitted to give the correct output impedance.

The output of the module also feeds the 6 MHz signal developed across L13, via C37, IC3 (XR215N) which is a phase locked loop detector. By changing the voltage applied to pin-12 it is possible to tune the PLL to accept audio carriers of differing frequencies than our 'standard' 6 MHz. This is achieved by RV5 on the PCB or if you wish this can be replaced by a front panel control (again the value can be 10k).

The XR215N suffers from the fact that it does not have a squelch circuit built in. An LM741 is connected as a comparator and can be linked to either the noise meter or AGC meter signal. The output of the 741 forces the shunt diode in the audio path into conduction in the absence of a signal thus shutting off the noise when you lose the incoming signal. The reference for the comparator can either be a potentiometer on the PCB (RV6) or you can wire it to a front panel control as an audio squelch control.

The audio after the squelch clamp is fed to the volume control and the to the audio amplifier IC3 (LM380) which gives about half a watt of audio to an external speaker.

What else is provided on the PCB. As mentioned earlier there are two signals from the module related to the received signal. One is the AGC level, and the other is the noise meter signal. Both of these are voltages, but are offset from ground so you need two potentiometers for each signal. One in series with the meter feed to set the maximum current through the meter and the second to set the return of the meter to correct the offset on the signal. Pairs of potentiometers are provided for the two signals.

The prescaler output of the module is connected to a pin on the PCB. This is provided to allow you to design a phase locked loop control to feed the tuning voltage to the module. Or as an alternative the signal could be fed to a frequency counter which, with suitable scaling factor, could give a reading of the frequency being tuned. (Buried somewhere in the junk on the authors bench is the prototype of such a device. Watch this space !!!)

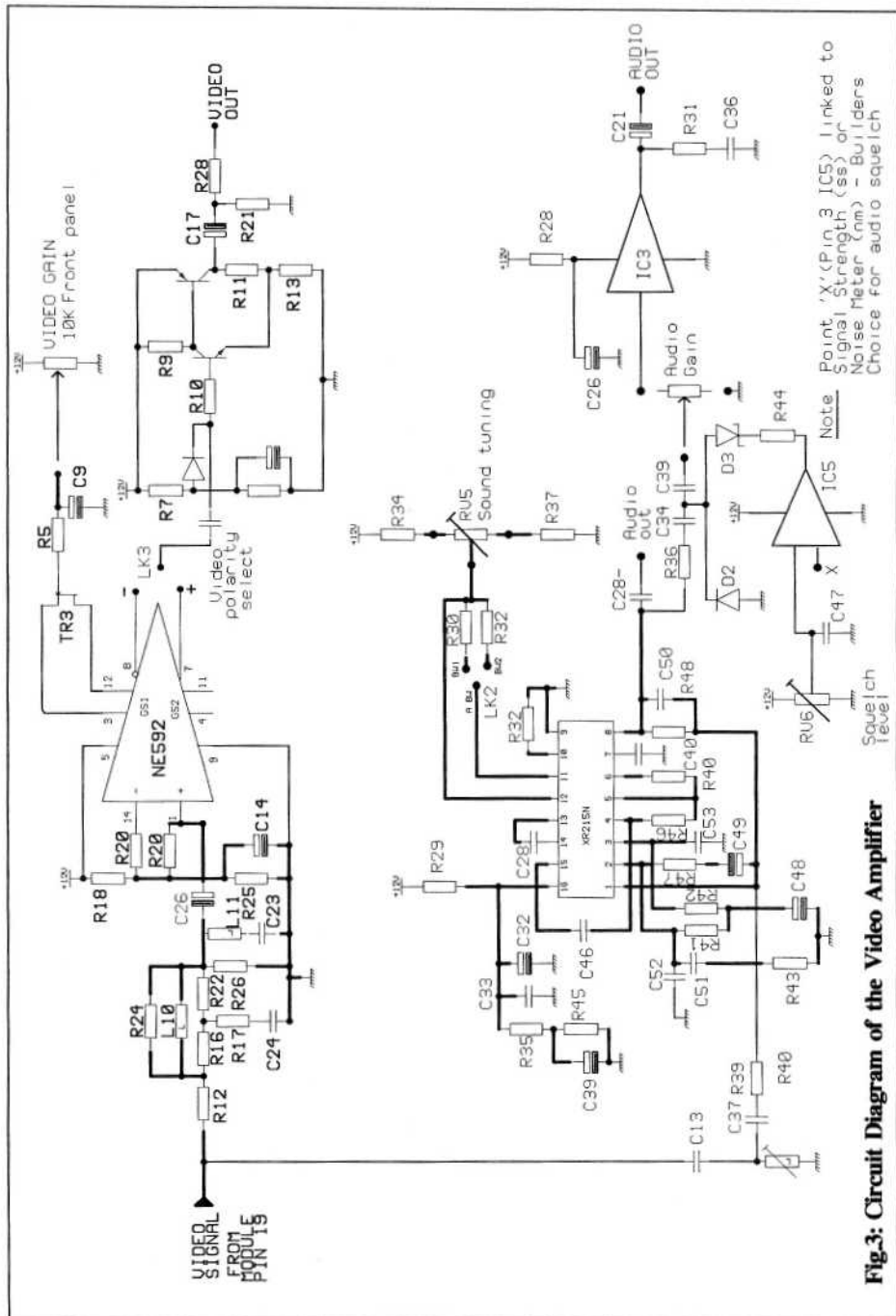

POWER SUPPLIES

As the author lives in a valley and is screened from the local sources of 23 Cm signal the design brief he gave himself for the PCB was that it would be powered by a stable, nominal 12 volts DC. This is all well and good except to tune the full range of the module a 22 volt supply was needed, also 17 volts is the normal voltage fed to LNB's if you feel like using the receiver for 10 Gigs, or one of the many satellites around these days.

The higher voltages are obtained by running a DC/DC convertor which has isolated outputs from the +12V supply, and then adding the outputs of the convertor to the incoming voltage. Thus the -5V o/p of the module is connected to +12V, making the 0 v become 17V and the +5V become 22V. The current capability of the 17V supply is approximately 70 mA with the NMA1205S module and approximately 200mA with the NMH1205S module which is the recommended device. The module require 12 volts and 5 volts for some of its circuits. The latter is obtained by a standard 5 volt regulator fed from the 12 volt supply.

Looking at the circuit diagram you may wonder why the component numbering does not seem logical. The reason is quite simple. You can follow a circuit diagram quite easily without using the part numbers, but if you have to find a particular part on a printed circuit board it can sometimes be quite difficult, particularly if the components are numbered sequentially on the circuit diagram. With the receiver the components are numbered logically from the top left of the PCB to the bottom right in rows. This way it is easy to find a component (if you know its number), but it makes the circuit diagram seem a little illogical. That's my theory and I'm stuck with it !!!

CONSTRUCTION

The first thing to do is to place the Vero pins into the board for connecting the external controls. These are pushed in from the bottom of the board and then tapped home to form a good mechanical fixing. Once they are all firmly home they can be soldered to their tracks.

Next, place the resistors, the diodes, the small capacitors, the IC sockets (if you are using them), the chokes feeding the module, the two in the audio circuit, the power supply module, the four potentiometers in the meter circuit (if required), the transistors, then the large capacitors. The IC's, MMIC and the GaAsFET are fitted next, the 'D' type connector (for the power in ,video and audio out), and the RF module is the last item to be fitted to the board.

Because everyone has his own idea about the ideal case for his project no case has been specified for this project, but the author uses a case supplied by Minffordd's of Ffestiniog (no the reason is not because I am a GW) and is model J20.

Fit the PCB into the case of your choice and couple up the external (to the PCB) controls and LED's.

There are a couple of points worth noting:

- 1.- There are two points on the PCB marked 1P and 2P. These are to allow a switch to be fitted to break the 12V feed to the preamplifier when the second RF feed into the module is selected. The use of a 3-pole double-throw switch to switch the A/B selector, the indicator LED and the preamp supply simultaneously is worth thinking about.
- 2.-If power to feed a masthead preamplifier or a satellite LNB then a switch in the supply feeding the 'LNB' point on the PCB is worth considering. (If a 4PDT switch is fitted that could do both jobs at once !).

Suitable switches can be found in the Farnell catalogue as part Nos. 151-172 (3PDT) and 151-173 (4PDT)

If the receiver is only to be used on 23cm then the 1P and 2P points can be permanently linked together. The audio demodulator used has the ability to have different bandwidths so a link will need to be fitted between the point marked A BW and either A BW1 or A BW2.

Another link needs to be fitted between the SQ point (just above the 741 op-amp) and either the S S (Signal strength) or the N M (Noise meter) pins. The Author has found that the N M is perhaps the better of the two.

TESTING

Having connected all the require external controls and a speaker the moment of truth has arrived.

If you have connected a supply to one of the LNB pins DO NOT CONNECT AN AERIAL TO THE RECEIVER !

Turn the audio volume fully anticlockwise.

With a multimeter set to Ohms measure the resistance between pins S S and SIG STRENGTH M- and adjust RV4 for maximum reading. Repeat for pins N M and NOISE M- adjusting RV2 for maximum.

Connect a 12 volt supply via the D connector (+ pin 1, - pin 5). With a multimeter check for +17v and +22v at the pins near PSU1.

If all is well turn up the volume until noise is heard. If no noise is heard at maximum volume, reduce the control to about half level and then adjust RV6 until noise is heard, then slowly adjust RV6 until the noise cuts out.

Connect a monitor to the video out connections on the 'D' type connector. There should be noise on the display. If not present turn up the video gain until it appears.

If you have connected a supply to one of the LNB feeds you must establish which connector it appears on. Using a multimeter check the coaxial connectors for the voltage you connected to the LNB pin. Mark this connector clearly as connecting an aerial to it will result in the feed choke associated with that input burning out as most aerials for 23cm have baluns or the active element is a folded dipole so to DC the aerial is a short circuit.

Now the aerial can be connected to the connector which does not have a supply connected to it.

A 23cm signal is now required. Tune the receiver to the signal. Adjust the video gain control for a good picture on the monitor. The audio muting should have lifted and noise be heard on the speaker. Assuming that the transmission has intercarrier sound adjust RV5 (or the front panel control if fitted) until the sound carrier kills the noise, or the correct sound is heard.

For the next operation a signal with intercarrier sound is required. An oscilloscope will be useful, but not essential to tune the audio carrier. Monitor the end of R39 at the end nearest to C38. With a suitable tool tune L13 for maximum 6 MHz signal. Move the oscilloscope probe to C17 and adjust L11 for the minimum 6 MHz signal in the sync and blanking area of the video waveform. RV5 (or the front panel control will now have to be adjusted to tune the audio signal.

If you do not have an oscilloscope then, with a signal with intercarrier sound adjust RV5 (or the front panel control) until the audio is received. Now carefully adjust L13 to improve the signal by reducing any background hiss due to low 6 MHz signal strength. L11 can be adjusted if any patterning is seen on the monitor when receiving a signal with intercarrier sound.

If you have fitted either (or both) the meters now is the time to set it (them) up. For the noise meter first adjust RV1 until the meter moves to about half scale. Retune the receiver until the monitor is only showing noise. Readjust RV1 until the meter is just showing a minimum. Retune to the signal and adjust RV4 until the meter shows full scale (assuming a P5 picture) or to a point which you can use as a suitable point for the strength of picture received. For the Signal Strength use a similar procedure except that RV2 and RV3 are the controls.

If the on-board preamplifier is in use the tuning will need to be adjusted and for this you will need a weak signal. Just adjust VC1 for maximum reading on the Signal strength meter, or if only the noise meter is fitted again tune for maximum signal.

That's all there is to the setting up. Good luck and I hope you have lots of enjoyable contacts using the receiver and I hope to work some of you one day both on 23cm and 10Gigs.

Now the burning question Does it work ? The Mk 1 prototype was in use on Myndd Prescelly, (Prescelly Mountain to you non Celts).

by GW8AGI and the Mk 2 on Hartland point by G8OZP during a recent 10 Gig trial. The signals received were between P1 and P5 over a distance of 112 Km. Not bad for my first 2 way 10 Gig QSO.

PARTS LIST

Qty	Package	Value	Components
12	C 0.2	10nF	C1,C19,C2,C3,C37,C4,C47,C5,C52, C6,C7,C8
5	C 0.2	100nF	C10,C12,C33,C36,C46
8	TANT 0.2	10 μ F	C11,C21,C22,C31,C32,C39,C44,C45
4	C 0.4	330pF	C13,C18,C24,C34
4	CAP_RAD 5M	100 μ F	C14,C15,C26,C27
4	C 1206-1	1nF	C16,C42,C43,C48
1	ELEC 1.35	1000 μ F	C17
2	CAP_RAD 2M	10 μ F	C20,C9
1	C 1206-1	4.7pF	C23
1	C 0.2	6n8	C25
1	C 0.4	33pF	C28
3	C 0.4	100nF	C29,C35,C40
1	C 0.2	100pF	C30
1	C 0.2	22pF	C38
1	C 1206-1	4.7pF	C41
2	TANT 0.2	1 μ F	C49,C50
3	C 0.2	1nF	C51,C53,C54
2	DIODE 0.3	1N4148	D1,D3
1	DIODE 0.3	10v Zener	D2
1	DIODE 0.3	4v7 Zener	D4
1	REGULATOR +	LM7805	IC1
1	DIP14	NE592	IC2
1	DIP14	LM380	IC3
1	DIP16	XR215N	IC4
1	DIP8	LM741	IC5
1	MMIC2	MSA0685	IC6
8	AXIAL 0.5	10 μ H	L1,L2,L3,L4,L5,L6,L7,L8
1	AXIAL 0.5	33 μ H	L10
1	1296 L2	PCB Etched	L9
1	1296 L3	PCB Etched	L12
1	DCON9	9-pin D	P1
1	DC/DC PSU5X2	NMH1205S	PSU1 Farnell No.200-128

Qty	Package	Value	Components
4	AXIAL 0.4	1k5	R1,R2,R3,R44
1	AXIAL 0.4	220Ω	R10
2	AXIAL 0.4	100Ω	R11,R13
5	AXIAL 0.4	75Ω	R12,R16,R22,R23,R26
2	AXIAL 0.4	68Ω	R14,R49
1	AXIAL 0.4	270Ω	R15
1	AXIAL 0.4	18Ω	R17
9	AXIAL 0.4	10k	R18,R20,R21,R25,R27 R33,R36,R4,R47
2	AXIAL 0.4	22k	R19,R41
1	AXIAL 0.4	300Ω	R24
1	AXIAL 0.4	47Ω	R28
1	AXIAL 0.4	10Ω	R29
1	AXIAL 0.4	3k3	R30
1	AXIAL 0.4	1Ω	R31
1	AXIAL 0.4	5k6	R32
1	AXIAL 0.4	3k9	R34
4	AXIAL 0.4	4k7	R35,R40,R45,R46
2	AXIAL 0.4	1k0	R37,R8
3	AXIAL 0.4	470Ω	R38,R39,R43
1	AXIAL 0.4	2k2	R42
1	AXIAL 0.4	100k	R48
1	AXIAL 0.4	27k	R5
2	AXIAL 0.4	1k2	R6,R9
1	AXIAL 0.4	47k	R7
5	TRIMPOT	22k	RV1,RV2,RV3,RV4,RV6
1	TRIMPOT	10k	RV5
1	TO92N	2N3904	TR1
1	TO92N	2N3906	TR2
1	TO92H	2N3819	TR3
1	MMIC2	AFT 10735	TR4
1	MINVAR_CAP	0.5-3pF	VC1
38	1mm	Vero pins	VOL CTR,VOL GND,VOL HI +,+/-,+12 +17V,+22V,-, 1P,2P,A BW,A BW1,A BW2 A/B,Ao,B/W A,B/W B B/W C, LD1,LD2,LNB A LNB B,N.M,NOISE PRESCALE,S.S SIG STRENGTH SQ, T1 Hi, T1 lo,TA,TA H TA L,TUNE,VID GAIN
2	TOKO	MKANSK1713HM	L11,L13
1	ASTECC	AT2320	RF Module-1



PARABOLIC
Systems AB

A NEW GENERATION OF 24cm FM ATV PRODUCTS



The World's smallest Satellite Receiver, with modulated output on 48.25 MHz with Audio on 53.75 MHz. 10 to 15V DC @ 400mA 65 x 35 x 160mm

£120.00



Same unit as above but with Video and Audio outputs. Will tune approx. 1200 to 1500 MHz. Both receivers deliver voltage for a preamp via the coax.

£120.00



200mW FM ATV Transmitter that tunes between 1240 and 1279 MHz in 1 MHz steps. Will drive the M57762 to about 10W. 10 to 15V DC.

£165.00

Shipping £8.00

All units carry a 1 year guarantee

Parabolic Systems AB, P.O. Box 10257, S-434 23 Kungsbacka,
Sweden. Tel: +46 300 410 60 Fax: +46 300 406 21

AN INSERT GENERATOR

Hans Wessels PA2HWG

The Insert Generator described here is intended to be used with the synclock unit given in CQ-TV 160. The generator produces an insert signal for the TDA3561A (pin-9) or for the TDA3505 (pin-11) RGB decoders. Furthermore, it produces a single-sided horizontal (black) contour signal and enables colour manipulation by inverting the Red, Green and/or Blue signals coming from the BBC-B computer.

CIRCUIT DESCRIPTION.

The circuit is given in Fig.1 The RGB signals received from the BBC-B via JP1 are buffered and shaped in U1A, U1B and U1C. Now the signals split-up two ways; at first let's look at how the RGB signals are going to the output connector JP2. The signals are passed through an exclusive OR gate where they can be inverted by SW1 for red, SW2 for green and SW3 for blue. By means of these switches it is possible to have in Mode 0 on the BBC-B, more colours than normally is possible. Furthermore, one is able to create some colour effects "live" on screen. The RGB signals are then fed to the output connector JP2.

In the second signal path after buffering the RGB signals is a double OR gate, U2A and U2B. In U2A the insert signal is carried out, while U2A creates an insert signal which is stretched in U4B in order to get a contour signal. The normal and the stretched insert signal are combined in U2C. U3D enables the insert to be inverted, so that the picture appears only on those places where the text is. The insert signal can be switched on by SW6, after which it is fed to the output connector JP2. Q1, R14, SW7, D1 and R15 perform a key-to-white function, the large value of R14 enables a smooth key-in (in fact, it almost looks if the text is mixed in). The output signal of JP3 can go to a coaxial T-piece, through which the reference video is also routed. The contour function works on the key function as well, so when switched on you have a different (wider) character set.

IN PRACTICE.

The insert generator is fed with the RGB signals coming from the BBC-B. The output signals are decreased to a level of 1 volt peak and then routed to the Teletext insertion points of the RGB decoder (for instance TDA3561A or TDA3505). The combined RGB signals are then to be converted into CVBS or "S-VHS" signals in either an

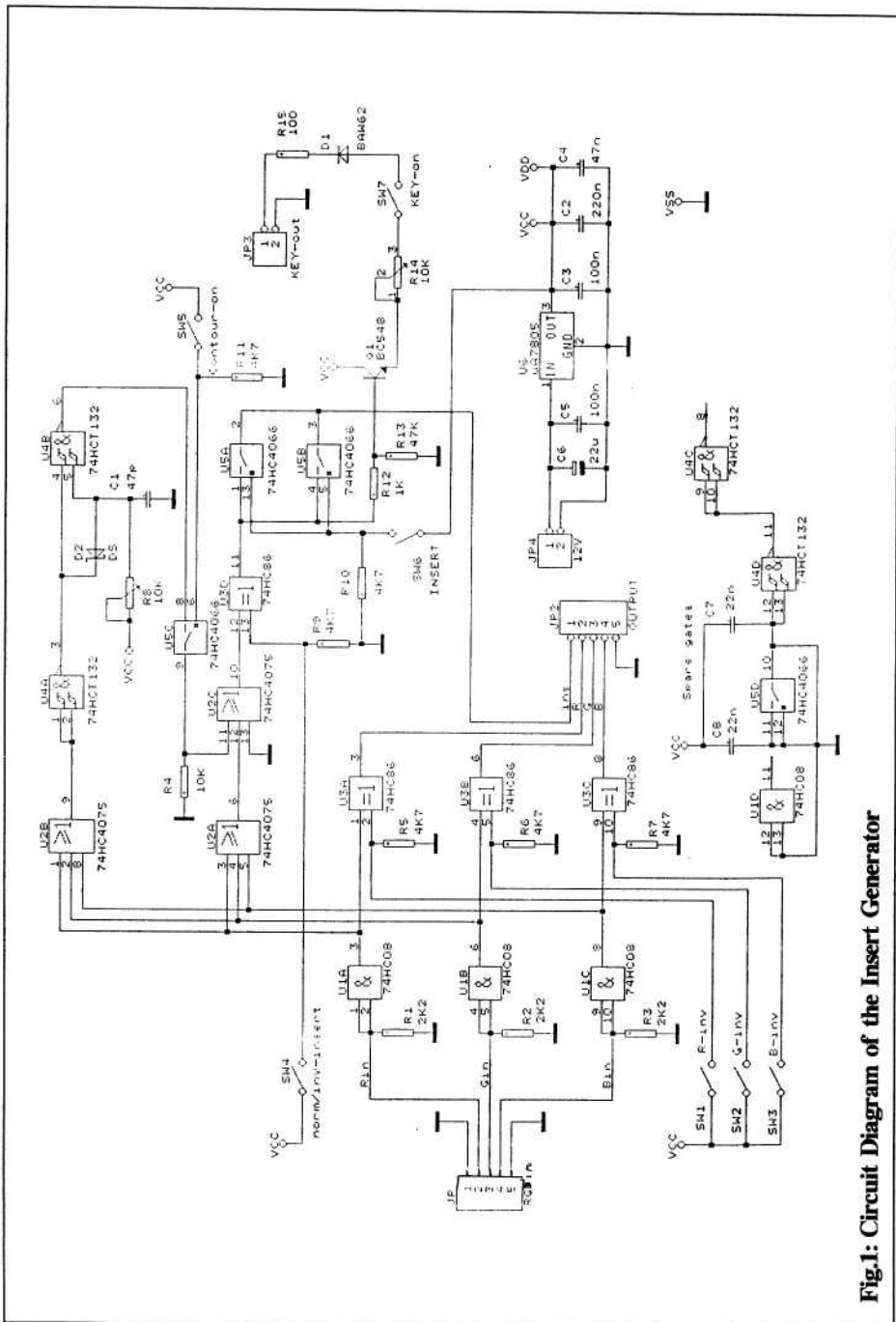

Fig.1: Circuit Diagram of the Insert Generator

MC1377 or MC13077. I have combined switches SW1, SW2 and SW3 into one BCD switch, which I think is more practical. There is no PCB designed for the circuit as there are many ways the circuit can be realised.

PARTS LIST

Item	Quantity	Reference	Part
1	1	C1	47pF
2	1	C2	220nF
3	2	C3,C5	100nF
4	1	C4	47nF
5	1	C6	22 μ F
6	2	C7,C8	22nF
7	1	D1	BAW62
8	1	D2	DS
9	1	JP1	RGB I/P
10	1	JP2	OUTPUT
11	1	JP3	KEY-out
12	1	JP4	12v
13	1	Q1	BC548
14	3	R1,R2,R3	2k2
15	3	R4,R8,R14	10k
16	6	R5,R6,R7,R9,R10,R11	4k7
17	1	R12	1k
18	1	R13	47k
19	1	R15	100 Ω
20	1	SW1	R-inv
21	1	SW2	G-inv
22	1	SW3	B-inv
23	1	SW4	norm/inv-insert
24	1	SW5	Contour-on
25	1	SW6	INSERT
26	1	SW7	KEY-on
27	1	U1	74HC08
28	1	U2	74HC4075
29	1	U3	74HC86
30	1	U4	74HCT132
31	1	U5	74HC4066
32	1	U6	uA7805

ADV IS HERE! (WELL, ALMOST...)

Andy Emmerson G8PTH

Back in the 1950s ATVers were pioneers: the early stalwarts in Britain were exploiting the UHF band (70cm) for television on a virtually daily basis at a time when broadcast transmissions of TV on UHF were still very much a thing of the future (1964 in fact). Regular colour transmissions by amateurs date back to the same period too. Even if these experiments contributed nothing to science and the commercial development and exploitation of television, at least those early pioneers deserve our admiration and some recognition.

When it comes to amateur television today, it's difficult to trace a similar kind of innovation. Of course some people will say that amateurs don't stand a chance: to do anything dramatic you need a microwave laboratory, surface-mount component technologies and a whole host more high-tech facilities that normal mortals cannot aspire to. If amateurs are leading the commercial boys at all, then it must be in the field of packet radio or in effective meteor-scatter communications.

But all this is about to change if Dr John Champa K8OCL has his way. His pet project is ADV - amateur digital video - which squeezes a virtually full-motion colour TV picture into the same bandwidth as a normal voice channel. This, if adopted, could become a world-wide video communication standard. It could also solve the spectrum shortage on 70cm, even allow world-wide ATV via satellites. Sounds too good to be true? Well, let's see...

One of the good-news stories of the past decade has been the hastening speed at which initially costly technologies get cascaded down to amateur prices. Look at hard disks for computers, CDs in hi-fi, even the satellite TV receivers that we ATVers now use for 24cm ATV. You can safely predict the same thing will happen to videophones. What videophones?

Good question. Earlier this year consumer videophones were announced on both sides of the Atlantic. In both cases it was indicated that the phones would cost about £500 and would be on sale in time for Christmas (though only time will tell whether these forecasts were right). But there's no doubt these products will reach the market, with the backing of BT and Amstrad in the UK and AT&T in the States. Where there is doubt is whether the public will take to them in the way their protagonists hope - they may turn out to be disastrous flops like the Sinclair C5 car or the Telepoint portable phones.

In any case, these are NOT the videophones that will get ADV off the ground. These initial systems are little better than a succession of colour freeze frames - rather like

SSTV in fact. They will also be analogue and will probably use proprietary standards and protocols which are incompatible with anything else. But there is another videophone revolution going on, one which is not dependent on the public's whims or the effect of the recession on consumer spending. This is the digital video revolution, as seen in business videoconferencing. The cost of travel is going up all the time, whilst the true cost of telecommunications is coming down. In the USA particularly, and even in Europe as well, big business is turning to video conferences and desk-to-desk video communications to cut the cost and time of travelling. Over the next few years this trend will grow and grow.

Business video telephony is succeeding because it uses digital techniques to compress a moving colour picture down to 64kbit/s: that's the data rate (or bandwidth if you like) of a standard voice channel. Pretty clever techniques (often - but not necessarily - using the assistance of a PC) are used to do the squeezing (digital coding) and unsqueezing (decoding), using a prime device called a CODEC (COder-DECoder). Current techniques give acceptable colour contrast and image resolution together with moderate motion rendering, and the technology will undoubtedly improve in the next few years - terrific prizes are there to be won by the successful companies.

So what does this mean for amateurs? Simply that CODECs will plummet in price and you'll be able to buy one on a card to plug into your PC. Connect up your video camera and two-metre rig and you're ready to send real-time video over terrestrial airwaves or even via an OSCAR satellite. Futuristic? Yes! Exciting? Yes! Make believe? Not at all!

Of course this does depend on a number of variables. The speed at which this technology becomes available is one of them and the enthusiasm of ATVerS to try something new is another. But the simplicity of the scheme makes it attractive to appliance operators as well as DIYers, and the whole thing will look a highly tempting proposition to manufacturers and value-added system dealers (the people who design package solutions from several firms' offerings).

So when will it take off - if it does? Probably after 1995. In that year the AMSAT Phase 3D spacecraft is scheduled for launch and this bird is due to have a digital transponder for international packet-radio communications. K8OCL is also pressing for it to have a 64kbit/s compressed digital interface system on board. By this time people should have caught onto the possibilities and potential of ADV.

ADV has other advantages. The narrow bandwidth of the signal (perhaps less than 100kHz) in comparison with analogue ATV will mean a much higher power density can be used, allowing greater range. Demands on other station equipment will be reduced: e.g. forward gain of antennas need not be sacrificed for the purpose of getting wide bandwidth. Equipment modifications may be unnecessary too.

What will it cost? That's difficult to say. In the USA the chipsets are expected to sell for around \$1,000 at the end of this year (1992), but there will be tremendous

commercial pressures to bring this price down. BT is working with IBM to develop new designs of video compression and processing chips, and many other industry giants are eyeing this market. My guess is that by 1995 the cost of adding ADV capability to your PC will be about £200 at today's prices - not desperately cheap but quite affordable if you've already found the cash to buy a computer.

Will it happen? Wait until 1995 to find out!

FURTHER INFO: Dr John Champa K8OCL c/o Unisys Corporation, 1 Unisys Place, Suite 5C51A, Detroit, MI 48202-4201, USA. Tel +1 (313) 972 2181.

Obituary

Julian Joseph Rose G3STO

Joe died suddenly on 22 November 1992, aged 48.

Joe was a keen television enthusiast and radio amateur, holding the callsigns G6STO/T and G8CTG as well as G3STO. He was a enthusiastic constructor and had many projects now sadly left unfinished. Joe operated "Monoculus" his outside broadcast van for many years and he was my introduction to amateur television.

A strong supporter of the BATC he was an active committee member from 1971 to 1980 and served as general secretary for 6 years.

He was also a member of the Lincoln Short Wave Club and had many other interests including Flying, Rifle shooting and Scuba diving.

His enthusiasm, his wide knowledge of the theory and practice of ATV and all aspects of engineering, his friendly manner and sense of humour all combined to make him a memorable character.

He leaves a widow, Pam G4STO to whom we extend our deepest sympathy.

Brian Summers G8GQS

LIGHTING ATV

Part-2

Norman Ash G7ASH

In the first part of Lighting ATV aspects of lighting techniques, illumination levels and the qualities required of the light itself were introduced. This brief introduction concludes with a look at lighting equipment and its use.

Many variations exist in lighting equipment. There are general purpose and special purpose sources, in a considerable range of power. Some have lens systems, others do not. Some of these types are adjustable, allowing the position of the lamp to be varied to either the reflector, or the lens, or both. This is known as 'Racking'; it adjusts the area of illumination by widening ('Flooding') or narrowing ('Spotting') the beam of light emitted.

Racking can be used to adjust light levels from each source. This 'balancing' of levels between one light and another is subjective, but in colour television the general preference is for a close ratio between 'Key' and 'Fill'.

A most convenient method of balancing light levels is to use spun fibreglass in front of the source. It is mounted in a frame or clipped slightly away from the lantern to

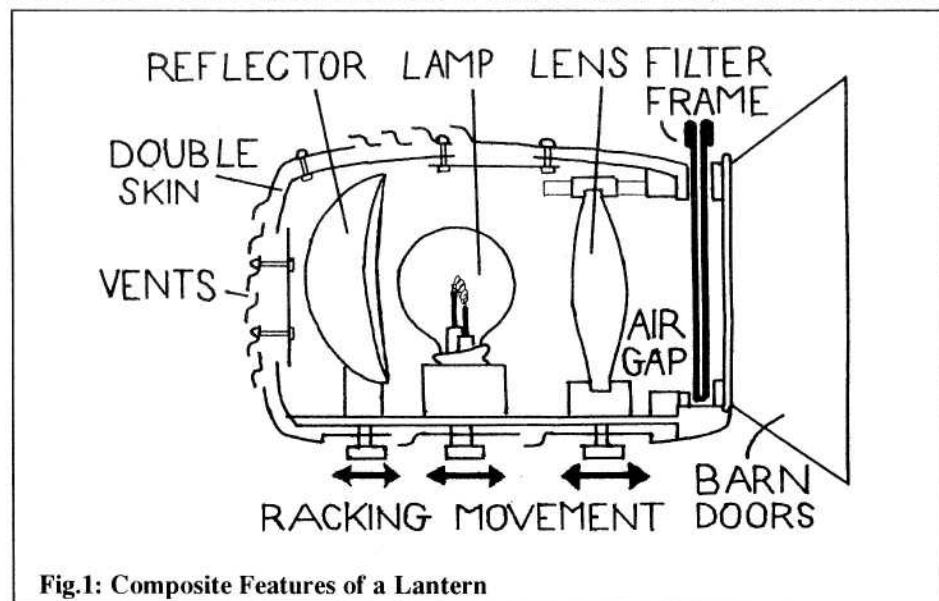

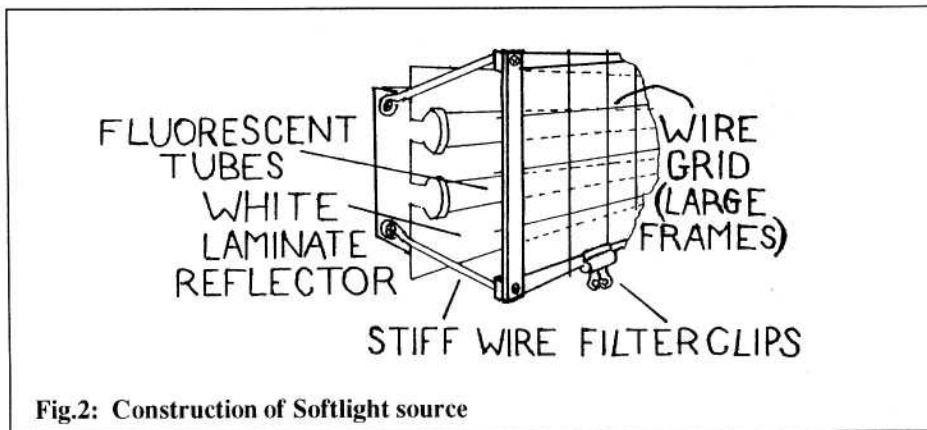

avoid its heat. Spun fibreglass is a more efficient method than using 'neutral density' filters for lowering intensity, as it diffuses the light. It is cheap and easier to obtain, although it is not as good as Opal ('Frost') filter as a diffuser. Its use has the advantage of helping to even out any patchy illumination from a poor quality source.

The 'Fresnel' type of lantern is a good all-rounder to have, where racking is provided. It has a special lens of concentric prisms, which is intended to even out the 'hot spot' in the centre of the beam, making it a controllable 'Flood'. It can be used to 'Key' and 'Fill' and also light specific areas. Second-hand theatre Fresnels may be available quite cheaply and some may be able to be up-rated' to Quartz Halogen (ask the manufacturer).

Checking equipment regularly is very important for safety, these same checks are recommended on second-hand equipment before you purchase. Correctly rated heat resistant cable should always be used near the heat source. Check the terminals and the plug if fitted. Often professional equipment is remotely fused and wires often work loose in constant use. Check the cable inside the lantern for insulation wear. Where racking is provided, check its full travel, noting that the cable does not get trapped. Mechanical fixings must be secure and independently earthed, to protect against a lantern becoming live. A second link to the fixing for overhead lanterns is recommended, such as a safety chain looped around.

To maintain the high output dust the lens, lamp and reflector, but do not wipe the highly polished 'front silvered' mirror type, just blow the dust off. The state of such a reflector should be checked when purchasing. Normally, any used lamp with it is of little, or no value, the amount of tarnish inside it should give an idea of its age however.

The main lighting feed should be through an accessible isolator switch. never use any combustible material to construct units, or in close proximity to them; always use the proper lighting filters.

There are two main drawbacks in using dimmers:

- 1) potential RF interference problems;
- 2) the 'colour temperature' varies dramatically with level adjustment.

Dimmers do however prolong the life expectancy of the lamps. Intensity can be varied without 'colour temperature' change by using multiple lamped sources, whose lamps are switchable in parallel with the supply.

Finally, it is possible for a competent home constructor to make some of the lighting equipment, if all the normal safety rules are followed. This brief article cannot give any detailed account, but may give an idea of the possibilities and problems involved.

Lamps often have a very narrow working temperature range. The lamp housing should be designed to dissipate the heat at a rate which maintains this temperature.

Multiple lamped units can use less powerful lamps to overcome this problem. Fluorescent strip lighting makes an extremely good 'soft light' source for 'Fill' lighting with a diffuser filter, although spot bulbs with integral reflectors can also be easily constructed.

Reflector design requires a high output with even illumination within the directional angle of the beam required. Unevenness shows up with patchy dips in level, as if lighting through trees. Cooking foil is too uncontrollable to use easily. The reflector from an old electric bar fire might provide an answer for short 'hot burning' tubes. Old car spot lights can provide other shapes for bulb type lamps. Cool burning lamps, such

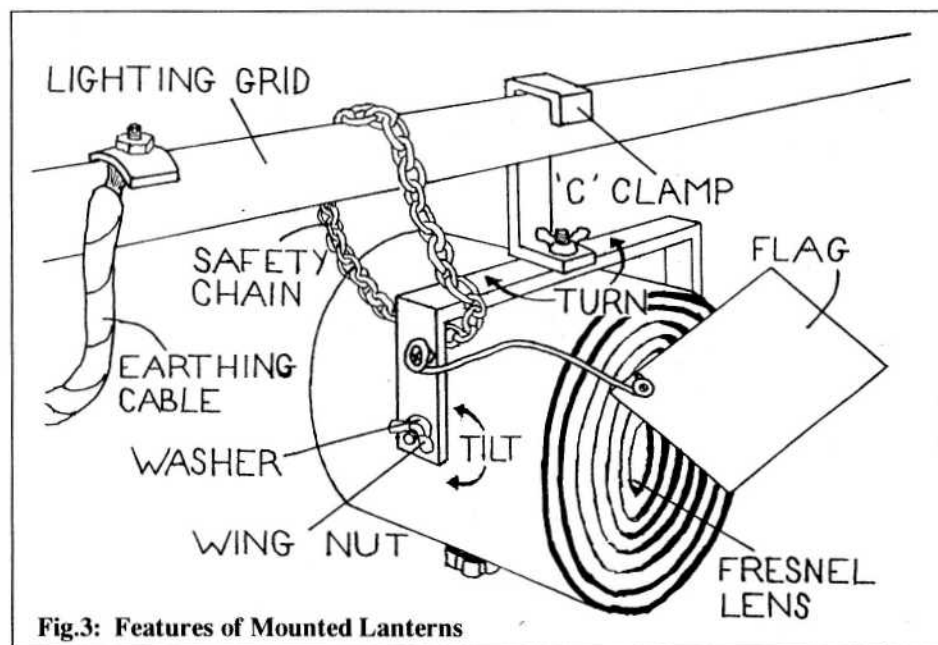

Fig.3: Features of Mounted Lanterns

as fluorescent tubes, can simply have a white laminate or paint reflector (double skinned construction is recommended for hotter burning lamps).

Adapting ready made lighting is recommended for directional and controllable units. Junk shops may provide old projectors which, with a wide angle lens, in a small studio, may make an ideal 'Key' source. Also, photographic flood lighting units would make convenient 'fill' sources once adapted.

These 'light weight' units might be suspended from a home-made 'lighting grid' made from gas pipe for a small studio and scaffolding poles for heavy units with larger spans.

If a pole is erected floor-to-ceiling in each corner of the studio and paired together by bars clamped firmly, so that the room walls support these without any movement, then lateral bars can be clamped across the top to the desired position for lighting. A short bar can be clamped vertically downwards off the grid to vary the height of the lanterns (safety coach bolts prevent the bar from dropping).

The lanterns need to be able to tilt and turn. A bolt through the pivot point can be clamped against the body of the unit using wing nuts and large washers. Though, in the turn movement this can be dangerous unless a restraining method such as safety chains is used.

Frames to hold filters can be made of flat metal bar. Overlapped ends can be bolted through and into a loop of stiff wire (made from an old coat hanger); the other end being self-tap screwed or bolted to the body of the unit. Allow an air gap behind the

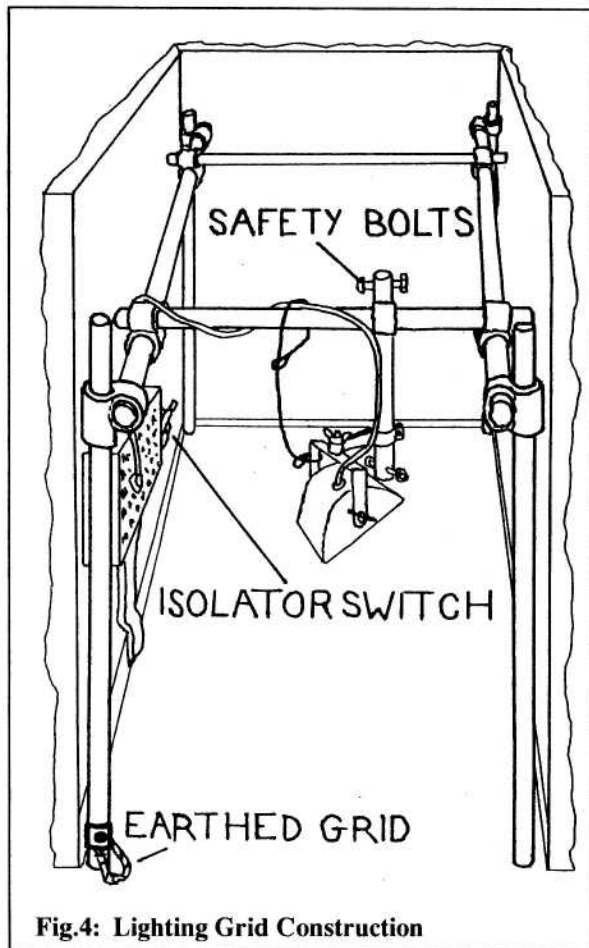

Fig.4: Lighting Grid Construction

frame. For a unit intended for soft light-diffuser, a large frame 30 to 60mm away should work better. Use small bulldog clips to hold the filters in position. Opal ('Frost') diffuser is recommended for 'Fill' lighting where affordable.

The looped stiff wire can also be used as a metal mask plate ('Flag') holder. Lanterns often have these attached (Barn doors) and can mask off the light to illuminate specific areas; these are normally matt black, but silver finished 'Flags' can be used as reflector panels also.

Parts for constructional work, such as 'C' clamps, should be available as spares for theatre lighting. Numerous books on lighting are available, in particular, the 'Focal' series on television includes a book on lighting for television.

TH2 IMAGING

AUDIO AND VIDEO COMPUTING SPECIALISTS

Tel : 0843 - 223831 / 596256

34 PRINCES GARDENS

MARGATE

KENT CT9 3AR



TH2SAT - PC Weather Satellite Decoder - £100 + £5 postage

TH2SAT is a software and hardware package that will allow the display of APT signals on an IBM Personal Computer (or compatible). The PC half card contains a single phono input socket, decodes all APT signals to 256 levels and samples at 4800Hz. The input signal level is controlled directly from the keyboard (no knobs to set up or adjust). TH2SAT works with VGA graphics and supports most Super VGA colour cards (for best results TH2 Imaging recommend Super VGA). Send SAE for details or £3.50 for a fully functional demonstration program (please specify disc size).

- 3 Video modes supported 320x200 640x480 1024x768 - all modes 256 colours
- Synchronises to METEOSAT, NOAA and METEOR
- Synchronises to METEOSAT start tone, built-in brightness controller from keyboard
- Aspect ratio correction selected from keyboard, zooms images to any level of magnification
- Colour images with dynamic range controls and multiple palettes, specific infra-red image palettes (temperature-slice)
- Built-in signal level controller from keyboard - no hardware set up
- Picture show facility and animation (up to 255 image files)
- 3-dimensional projection with two linearity modes and three intensities
- High-pass (three intensities), low-pass and median filtering, image negation and inversion
- Contrast equalisation enhancement and contrast stretching and histogram frequency graph
- Unattended operation of up to 99 passes or frames, PCX image translator program included
- Simple menu-driven system - no mouse required

METEOSAT Loop Yagis - from £50 + £6 postage

TH2 Imaging supply loop Yagis (complete with "N" type connector) for METEOSAT reception. They are provided as an easy-to-assemble kit.

Modifications to the Amstrad Computer Modulator Converter MP-3

M.R.Perry G8AKX

At the time of writing (Nov 92) a number of the above units have appeared at various rallies. It is designed to sit under the Amstrad CTM 644 RGB monitor to make it into a TV receiver. However, it was intended for export (PAL B/G system) and has 5.5 MHz sound spacing. An audio amplifier and speaker are contained in the tuner, which covers the 40 MHz, 200 MHz and UHF TV channels.

A 12V DC regulated supply at approximately 200mA is obtained from the monitor to power the converter, but if used with other monitors, such as the CTM640, a separate PSU is needed. Note: the OUTER of the DC connector is positive. The as designed for use with linear monitors and has an output level in the order of 2V peak RGB and composite video, which is also used as V+H sync for the monitor, but it seems that sync is superimposed on the RGB signals as well.

Front controls consist of COLOUR, CONTRAST, VOLUME, TUNING, VHF-L / VHF-H/ UHF. RGB output is via a 6-pin DIN socket. The on/off and brightness controls are on the intended monitor. Pin connections (clockwise from top):

- 1..... Red
- 2..... Green
- 3..... Blue
- 4..... Composite Video
- 6 and SHELL Ground
- 5 and CENTRE not used.

As it stands it could be of interest for DX TV. However, one dealer was providing with the unit two 6 MHz filters to replace the 5.5 MHz ones, so it can be converted to the UK standard. However, there are two modifications that may be of interest to the TV amateur:

- Firstly; by linking out a resistor the UHF tuning range can be extended down into 70cm and therefore is a basis for an ATV receiver.
- Secondly; the output from the IC video detector stage is at approximately 2V positive-going composite PAL video. Therefore, by tapping in at this point the unit can be used as a composite video-to-RGB converter. This video signal is, however, superimposed on a 5V DC bias level and requires isolation. Simple capacitor coupling was found to be satisfactory, with two resistors to restore DC levels to RGB circuitry when the output from the IC is broken.

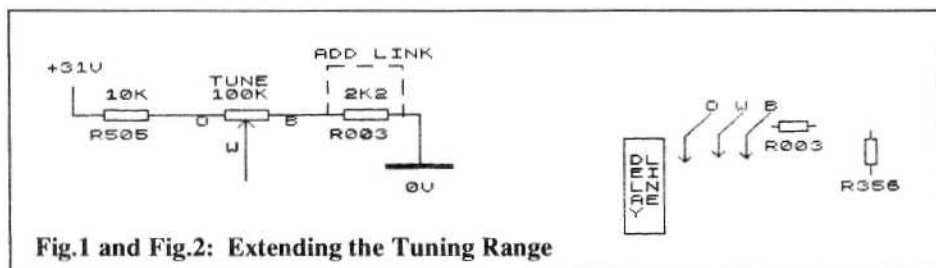

Fig.1 and Fig.2: Extending the Tuning Range

Check that the voltage derived from the resistors is of the order of 0.25 to 0.5V higher than that from the IC to maintain correct polarisation of Cx when in TV mode. Figures 1 and 2 detail the modifications to increase the tuning range, whilst Fig's.3 and 4 show the alterations to the video circuitry.

CARRYING OUT THE MODIFICATIONS

To open the case remove three screws from the underside. Turn the correct way up and carefully ease the top cover upwards at the front until the pegs clear of the associated lugs on the front moulding. Disengage the halves at the rear and then slide back to clear the aerial socket.

Note: it is not necessary to remove the front or PCB just to extend the tuning range, but it does require removing to replace the 5.5 MHz filters or to carry out other modifications.

To lift the PCB remove the small knobs (the tuning knob can stay). Now note carefully how the band switch extension is fitted, as it will fall off when the front is removed. Turn the unit over and three square recesses will be seen that have the ends of the retaining clips showing. Press these down one at a time, starting at one end until the front separates from the base. Unplug the speaker and power leads from the PCB. Note how the power lead is snaked around plastic projections to form a crude method of strain relief, as this will also come loose when the PCB is removed. The board can

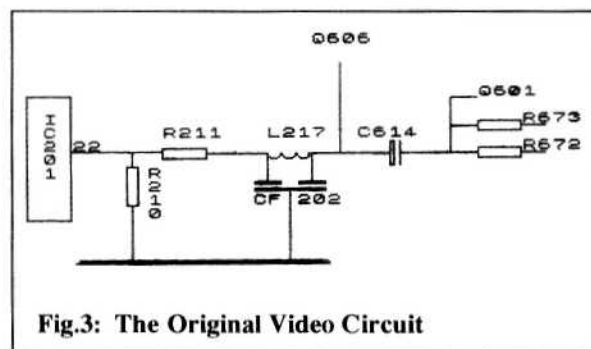

Fig.3: The Original Video Circuit

now be released from the front clips and lifted out of the rear retainers.

I suggest, for video input a miniature switched jack socket is used which can be mounted on the front panel.

Whilst the PCB is removed, and if the unit is going to be used other than with the

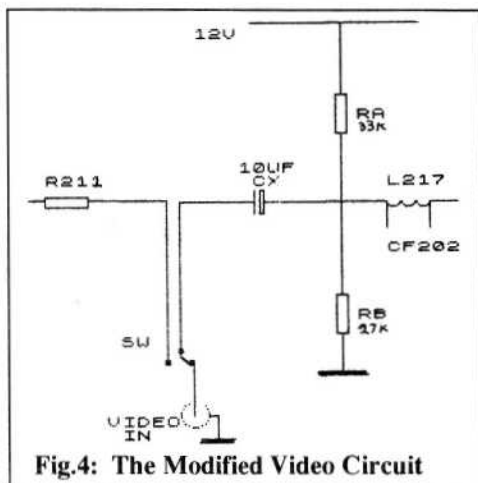

Fig.4: The Modified Video Circuit

intended monitor, it is a good idea to fit a reverse-polarity protection diode (i.e: 50V 1A). The PCB already has provision adjacent to the power connector. Positive towards the edge of the PCB.

To extend the tuning range locate R003, (2k2) adjacent to the blue lead near to the large black delay line. Either replace the resistor with a link or solder a link across it. An alternative method would be to cut the blue lead at this point and solder to earth point, such as a lug on the TV tuner.

C614, R211 etc., will be found approximately half way on a line between the

delay line and two small coil cans next to the tuner. Either cut the track between the ceramic filter and C614, or a far simpler method is to lift one end of R211 (the end nearest C614). One end of CX can now be fitted in this vacated hole. Miniature coaxial cable or video cable now connects to socket. This second method does mean that the video input signal passes through the filter, but with no apparent deterioration.

Reassembly is a reverse of the above disassembly, not forgetting to ensure that the band switch is fitted correctly in place, together with power lead.

At time of writing the MP-3 was available from Greenweld, 7-17 Park Road, Southampton. SO1 3TB; Tel: 0703 236363 at £14.95 + £2.75 p&p. However, due to the lead time of the magazine this may not still be the case. I have also seen them on the rally stands of G S Electronics and Chase Surplus.

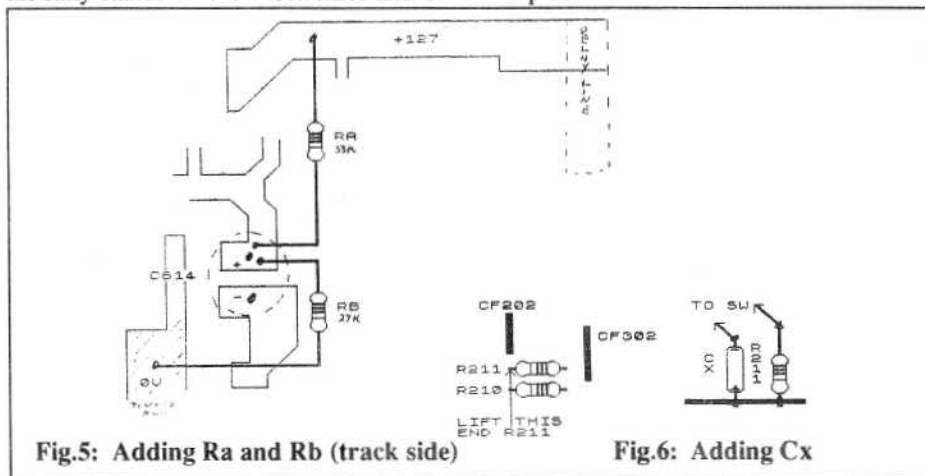

Fig.5: Adding Ra and Rb (track side)

Fig.6: Adding Cx

Auto SCART Switching Your TV

John Stockley G8MNY

This circuit is for those of you who do have a Scart "tally" wire on your video gear, but do not want the additional 12 volt SCART switching wires all around the shack.

Firstly, find the +12 volt rail in the television or video (most televisions' have one nowadays) if only other voltages are found the circuit will need modifying.

The circuit is the simplest that I could get to do the job, just four resistors, two capacitors, one germanium diode and a PNP transistor.

The Transistor is turned on by negative sync video pulses. The positive signal is fed by the diode into the high impedance bias circuit. The bias level has been designed to be just under that which turns the transistor on. This means that only a very light load is put on the video signal, and that is via the input 680 ohms resistor and 0.1uF capacitor.

The output tally signal (+10V) is current limited through the 330 ohm resistor, so it should not upset the television's +12 volt rail. The output pulses are damped out with the 2uF capacitor.

Check that the tally signal goes from about 1 volt with no video, to +10 volts with normal video, and that it is still high with only 0.3 volt peak-to-peak black and sync signal. The circuit may need setting up if the components, the 12 supply rail, or the video level are different.

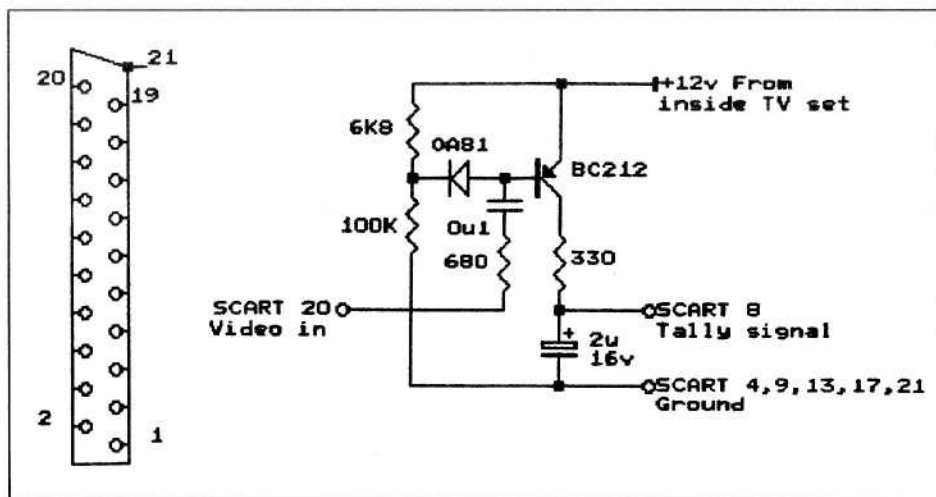

SATELLITE TV NEWS

Paul Holland G3TZO

Welcome to another year of Satellite TV News! I am sure that the next twelve months will once again provide a fascinating variety of developments in the satellite world with new satellites and services appearing and some familiar names fading into history. This year will hopefully see the launch of ASTRA 1C and Eutelsat II F5. We should also by now be seeing the launch of services on Spain's HISPASAT satellite at 31.0 deg W. I hope to be able to reflect all these developments throughout the year and look forward to receiving your news and views on the rapidly changing satellite world around us.

My thanks to those of you who wrote asking for a report of visible satellites over the horizon for their QTH. I had not realised quite how many trees would be felled as a result of my offer in CQ-TV 160 so I hope that the data supplied was useful!

In this issue of Transponder Report I have occasionally indicated reception quality using the BATC signal quality reporting conventions. This may help you make a judgment as to whether your system is performing as it should. Bear in mind all the variables of weather, Lat/Long and system specification in making any comparisons. To help I will give a quick run down of the relevant equipment in use at this QTH.

- ✓ Antenna: 1.8m centre focus (petalised) gain unfortunately not known but assume about 43.0 dB.
- ✓ Polariser: SMW Ferotor with SMW Depolariser for converting circular to linear polarisations.
- ✓ LNB: SMW Triple Band. Noise Figure Max 0.9db
- ✓ Receiver: Nokia Sat2200 Demod threshold 6.5dB IF Bandwidth 27 MHz

The addition of the Swedish Microwave depolariser to my system last summer improved reception of a number of circularly polarised signals, notably those from Tele X. The theoretical improvement is 3.0dB, however the subjective improvement is from a P3/4 to P5 on for example TV4.

The depolariser is fitted immediately behind the feedhorn in line and preceding the polariser. The depolariser simply consists of a dielectric low-loss slab contained within the circular waveguide section. The orientation of the slab must be vertical within the waveguide to minimise attenuation or distortion of linearly polarised signals. The WR75 flange of the connecting LNB is fitted with its electrical plane at 45 deg to the dielectric slab. With the depolariser fitted in this way, circularly polarised signals are selected as linear signals. The insertion loss of these devices is typically 0.1 - 0.15dB.

TRANSPONDER REPORT

Eutelsat have reported the decision to launch Eutelsat II F5. The manufacture by Aerospatiale of Eutelsat II F5, previously designated as a ground based reserve, will be completed by April. No launch date has yet been fixed. The satellite will have enhanced Widebeam coverage for eastern Europe and will carry both business communications and television transmissions. No orbital position has yet been announced.

DFS 1 Kopernicus 23.8 Deg E

Late November saw the launch of N-TV, a new German news channel, on TP1 (12.524 GHz V). It is rumoured that this Channel together with VOX TV, a German news & information channel, may be carried by ASTRA 1C.

ASTRA 1A and 1B 19.2 Deg E

Two Spanish channels backed by Canal Plus should by now be carried through ASTRA 1B. TP30 is allocated to CINEMANIA, a new film channel, with TP 32 carrying a channel based on science, nature and culture. Both channels will be in PAL and encrypted using the Syster/Nagravision system. It is likely that unencrypted programming slots will occur.

Rumours abound as to the likely incumbents for ASTRA 1C when it launches in a few months time. The current candidates are: A "Bouquet" of French channels from TF1, German Channels N-TV, VOX TV and RTL2, Filmnet Plus, Discovery, Bravo, TV Asia, Channel 5, The Games Channel, Nickleodeon (a Film Channel), Disney Channel and a further two Spanish language channels.

Some of the channels listed above should be seen as highly speculative possibilities. There are however other candidates, such as a consortium of UK ITV companies and Thames TV which could be seeking ASTRA 1C capacity. Time will tell!

The German channel Tele 5 was scheduled to close in January on TP21 with DSF, a new 24 hour German Sport service, appearing in its place.

Eutelsat II F3 16 Deg E

Since its launch last year this satellite has seen a steady increase in the services carried. Scheduled for launch in March on TP 32 (11.554 GHz H) is the Polish state broadcasting channel, provisionally entitled Polonia Sat. This service joins the Hungarian channel Duna 7 launched before Christmas on TP 33 (11.595 GHz H). An Egyptian channel was also due to launch in late December however at the time of writing no details were available.

Eutelsat has announced tests of a Digital Satellite Radio (DSR) system on this Satellite. Based on the German standard now in use on Kopernicus. The system would support up to 16 stereo radio channels from one transponder.

Eutelsat II F1 13 Deg E

January saw the launch of Euronews on Widebeam TP 37 (11.575 GHz V). Transmitting in English, French, German and Spanish this pan European news channel will broadcast for 18 hours a day. RTL 2 was scheduled to launch on this satellite early in the new year using TP 21 (11.096 GHz H) last used by the now defunct PAL feed of Der Kabekanal. Rumoured events relating to the transponders on ASTRA utilised by Screensport and Lifestyle could mean that RTL 2 will be carried by ASTRA 1A in preference.

Plans are in hand for Red Hot Dutch to change encryption on 1st February. Early reports had suggested that Cryptovision was the likely system to be chosen. The odds were narrowing at the time of writing to a new system entitled Enigma. This system is based on the familiar "cut and rotate" process, but will have a secure over the air addressing system, hence requiring no smart card. Enigma apparently will be able to handle up to 32 channels with up to 8 different access levels per channel.

Eutelsat II F4 7 Deg E

As predicted in CQ-TV 160 the Greek & Cypriot channels RIK and ET1 emerged from the noise on Widebeam TP 22 (11.144 GHz & 11.178 GHz respectively). Signal levels are only P4 at this QTH due to the use of half transponder mode for these channels (3dB down). January saw the transfer of EBU traffic from Eutelsat 1 F5. This move coincides with the merging of the EBU with eastern Europe's Intervision network so we can expect to see some interesting developments over the next few months.

Tele X 5 Deg E

Filmnet have now taken a controlling interest in the operating company for Tele X (NSAB) and have indicated that they could be interested in locating a second satellite at this position to provide an increased range of programming for Scandinavia. Marco Polo 1 at 31.0 Deg W could be the target now that transmissions have ceased.

Intelsat VA F12 1 Deg W

This satellite should now be in inclined orbit with traffic transferring to Intelsat 515 at 18 deg W. Up until late November however TV4 (11.133 GHz H) was operating in full transponder mode with signals up from P1 to P3. There is no news so far of the relocation of Marco Polo 2 to this orbital position. Telecom 2B 5 Deg W. Reports have been circulating that TF1 will be launching its own bouquet of 6 channels on this satellite in the New Year. No details were available at the time of writing.

Telecom 2A 8 Deg W

The confusion caused by arguments between Canal Plus and the French Government over transmission standards for this satellite was eventually resolved in favour of Canal Plus.

The line up of channels is as follows:

- TP R4 (12.648 GHz V) - Canal Plus (France)
- TP R6 (12.732 GHz V) - Canal J & Canal Jimmy
- TP R7 (12.543 GHz H) - MCM
- TP R8 (12.585 GHz H) - Planete Cable
- TP R9 (12.627 GHz H) - Cine - Cinefil
- TP R10 (12.669 GHz H) - Cine Cinemas
- TP R11 (12.711 GHz H) - TV Sport

All the above are in Secam and encrypted using the Syster system. Canal Plus is being carried on TP R1 (12.522 GHz V) in D2Mac and will carry a percentage of programming in 16:9 widescreen format. Cine Cinemas is on TP R5 (12.690 GHz V) also in D2Mac and providing 16:9 programming. This latter channel may give way during the year to another new channel Canal Plus Plus, however no details are yet available of when this may be. Other D2Mac channels are film channel Cine-Cinefil (12.606 GHz V) and France 2 (12.564 GHz V). With the exception of France 2 all D2Mac channels will be encrypted using Eurocrypt.

Intelsat V-A F F15 18.5 W

All the Scandinavian services have now transferred to this satellite from Intelsat 512 at 1.0 deg W. Transponder allocations are as given in CQ-TV 160. TV2 has, as predicted, commenced using full access on its D2Mac Eurocrypt service although the test card is carried in the clear. TVN in PAL is now much improved at P5 compared to barely P2 pictures received previously from Intelsat 515.

Intelsat K 21.5 Deg W

Although of only academic interest to those of us in Europe, there are now several DTH services to North America from this satellite. Four channels known collectively as Europlus are uplinked by Telespazio from Rome. At least one of the 4 channels is sourced by RAI. A further German service known as Teleplus and uplinked by the DBP provides a fifth TV channel. It might be interesting if our American cousins reciprocated!

Intelsat VI F4 27.5 Deg W

Kanal Market (11.660 GHz V) began test transmission in late November. Kanal Market is a Turkish language home shopping channel.

Hispasat 1A 31 Deg W

Test transmissions started from Hispasat 1A in November with a mixture of test cards, promotional videos and unmodulated carriers. Signals in the DBS band from the two DBS transponders utilising LHC polarisation are P5++ here despite using my 1.5m offset antenna with linear polariser. Signals in the Telecom Band using linear polarisation are P4 using the same antenna.

Intelsat V F6 34.5 Deg W

The east spot beam of this satellite has been repointed with the beam centre over Geneva to provide better coverage of northern Europe in anticipation of growing service demand.

PROFILE - HISPASAT

This satellite, launched in the autumn of last year, was scheduled to become operational in January. Unlike Astra 1C, which has a full order book of broadcasters in advance of launching, Hispasat looks set to become somewhat of a celestial Cinderella. Even as Hispasat went into orbit SES, who operate ASTRA, were signing up key Spanish broadcasters to take transponders at 19.2 deg E rather than 31 deg W.

There is an unfortunate feeling of 'deja vu' as Marco Polo 1 leaves this orbital position, having proved the DMAC technology, but failing to get the necessary audience. At this time, therefore, I am unable to confirm any firm allocation of transponders.

The more rigid regulatory regime and State sponsored broadcasting in Spain should guarantee that at least initially some state channels will take up options.

HISPASAT 1A - Principle information:

Manufacturer:	Matra (France)
Type:	3 Axis stabilised Eurostar platform
Weight:	2075 kg
Launch vehicle:	Ariane 44LP
Operating life:	10 years
Frequency bands:	Uplink: 14.000 - 14.500 GHz Downlink: 11.450 - 11.700 GHz 12.100 - 12.500 GHz 12.500 - 12.750 GHz
Channels:	10 ku-band with 36 MHz bandwidths; Linear Polarisation 4 ku-band with 54 MHz bandwidths; Linear Polarisation 4 ku-band with 72 MHz bandwidths; Linear Polarisation 2 ku-band with 27 MHz bandwidths; LHC Pol
Coverage:	Spain and The Canary Islands (Spot Beam) N and S America (Global Beam)
EIRP:	FSS Band - 49.5 dBW (Canary Islands) 52.0 dBW (Iberia) DBS Band - 58.0 dBW (Iberia)
Footprints:	See Fig.1

PRODUCT REVIEW - Update

In CQ-TV 160 I gave a short review of the SATMASTER software available from Swift Publications. Since that review was written I have been provided with a copy of the latest SATPRO programme. This software does everything that SATMASTER does but has some very useful additional facilities. The main differences to SATMASTER are as follows:

- An improved menu layout with additional pull down menus and options
- Support for laser printers and is now capable of printing footprints to printer without latest version of DOS
- Displays CCIR rain climatic-zone maps for the World, Europe and the Far East and seasonal temperature maps.
- It now automatically takes account of circular or linear polarisations in the link budget analysis.
- It lists the polar and apex elevation per town - a very useful feature.

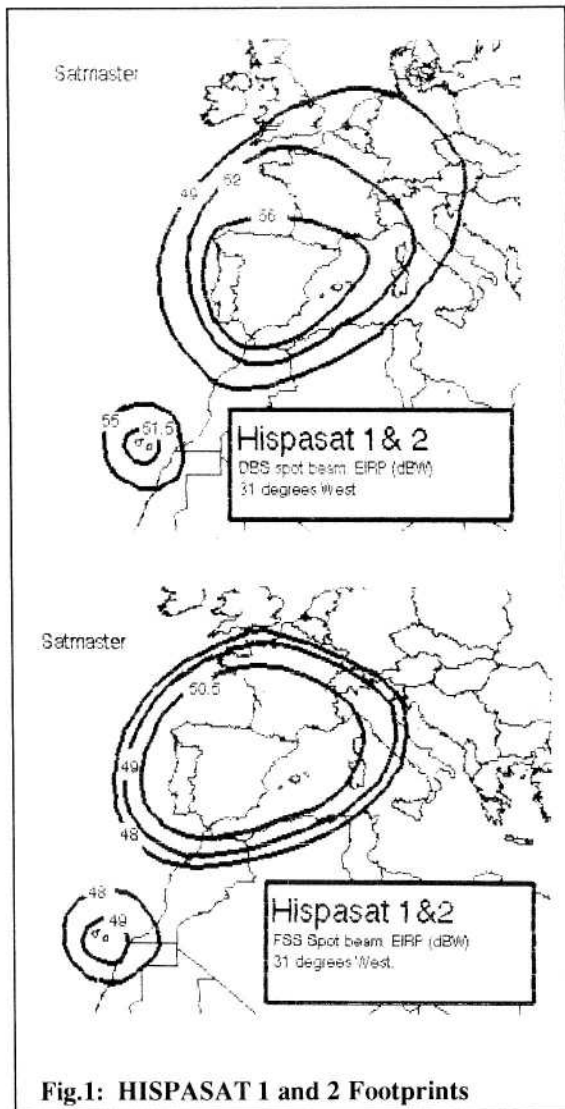

Fig.1: HISPASAT 1 and 2 Footprints

- The rain fade margin is now calculated automatically
- It contains World seasonal vapour density (absolute humidity) data to predict absolute absorption by water vapour .
- It is able to predict rain attenuation, atmospheric absorption and cross polar discrimination.

I have used the programme for a month or so now and can find no obvious bugs or substantial reasons for not recommending SATPRO to anyone who has the need or

interest to play with link budget calculations. SATPRO is available from Swift Publications at 17 Pittsfield, Crickslade, Swindon, Wilts. Tel: 0793 750620 and costs £69.00 plus p&p.

PRODUCT REVIEW - SATAURU 101

During my visit to last years Northern Video & Hi-fi Show I spotted an interesting new Scart Switching product called the Satauru 101. The SATAURU 101 goes a step beyond equipment such as the PERISWITCH in enabling up to 7 different decoders to interface with a Satellite receiver simultaneously. The SATAURU 101 will also permit simultaneous viewing of the TV whilst recording satellite programmes or the simultaneous viewing of satellite programmes while recording terrestrial TV programmes. All coupling is achieved through Scart connectors.

I tried a SATAURU 101 using a variety of different decoders that are currently connected to my domestic system. Unfortunately, I did not have enough different decoders (hollow laugh from the XYL) to test every configuration possible with SATAURU 101. The SATAURU provides connections for the following system components:

- Two decoders operating with composite video levels i.e: a standard Videocrypt decoder (Sky Sports, Movies etc.)
- One decoder operating with composite video levels plus audio decoding i.e: Discret (Canal Plus)
- Two audio only decoders (BBC Europe, Bravo)
- One Mac decoder (D2Mac or Dmac for Filmnet, TV1000)
- One Secam decoder (M6, TF1, etc.)
- Satellite Receiver
- VCR
- TV

Results were excellent once I had learned the basic rules of operation. Switching from one decoder to another was fast with no observable degradation of picture. I did, however, learn the hard way that the handbook means what it says. All Scart connections should ideally be fully wired. If pin-8 of the Scart which carries the 12V switching signal is not operative, then the component will not be looped through. Additionally, I found that it is also necessary to make a baseband connection from the Satellite Receiver to SATAURU even though all other connections were in place. This was not explained in the handbook, though I understand that Deben Electronics, the manufacturer, has now clarified this point for future deliveries.

One significant point for me was the size of the unit. It matched neither the width of either of my two VCR's or Satellite receivers. As its very existence stems from the equipment with which it connects, it seems a shame that it does not match their size.

The unit itself is manufactured to a higher standard than many current Satellite receivers on the market. The connectors are all solidly mounted to a mat black metal chassis and the internal PCB is professionally laid out. The internal power supply is clearly up to the job as is evidenced by the weight of the unit!

This product not is not inexpensive at 299.00, but will no doubt find a home with those people who are struggling to assemble a multi-satellite system utilising multiple decoders, without the need to keep changing over connector leads. Contact Deben Electronics, Deben Way, Melton, Woodbridge, Suffolk, IP12 1RB. Tel: 0394 387762 or Fax: 0394 380373.

ON LINE EUTELSAT INFORMATION SERVICE (OLE !)

For those wishing to keep BT's profits up (I think you should) you might try calling Eutelsat to try their on line information service. You can either select a voice activated response or use a fax machine to obtain information on a range of topics about Eutelsat and its activities. The number to call is 010 33 1 43 21 23 38. You will need MF tones on your fax to signal your responses.

That's all for this issue of "Satellite News". Please do keep on writing to me telling me what you are doing in the field of satellite television and let me know what it is that interests you, the address is on the 'Who To Write To Page' in the supplement.

THE CLUB'S NEW SSTV BOOK

REVIEW

Pam Penlington GW0LAL

It was with great pleasure that I opened my mail recently and found a new publication on SSTV. Far too little is published on this aspect of our hobby and it is very difficult for people to obtain the information they seek. As a one-time SWL I know what it is like to trying to find out more about SSTV, or where to get the information from. This new book will, I'm sure, be of great benefit to many people newcomers and more experienced operators alike. The book is entitled "Slow Scan Television Explained" by Mike Wooding G6IQM and is published by the BATC. In general, the book is nicely presented, easy reading for the less technical amongst us, but also covers quite a range of the various aspects of the mode.

The reader will find that some sections of the book are reproduced from the earlier book "The Slow Scan Companion" (by Grant Dixon G8CGK, John Wood G3YQC

and Mike Wooding G6IQM, published BATC), these sections will I think prove to be of great interest to quite a number of people because it provides some background information on earlier equipment and the origins of SSTV. In these days of black-box-operating there are still many people who like to construct, experiment and modify equipment; for those the book includes a number of useful and interesting circuits. These circuits could be a very interesting project for the Winter months.

Computers are now playing a major roll in most slowscan shacks and this section is very interesting, because computer generated SSTV is becoming more prominent on the bands. Spectrum SSTV has been around for some time in recent years, followed by the Amiga and Atari with very good results. Although the PC has for some time been used interfaced to dedicated units for save/load facilities, it has only this year joined the scene with it's own SSTV software. The book covers all the up to date developments on computer SSTV.

For those who would prefer a dedicated SSTV unit, a range of commercial units from the older equipment up to the latest SuperScan 2001 is included. Obviously, in a book of this size and varied aspects, not all available equipment has been included. I doubt if the older units mentioned are any longer commercially available, but could appear on the second hand market therefore need a mention.

Slow scan techniques are well covered and should be instructive to the newcomer setting up an SSTV studio for the first time, this also applies to the explanation on the various modes, which can be very confusing until you are familiar with them. The demo SSTV pictures included are adequate, but don't really show the true quality of pictures one can expect to receive on air. The quality to be found these days is excellent, the majority of B/W is excellent, extremely detailed especially from some of the German stations, although lower quality is still seen. It would be impossible in this book to show the professionalism of a colour SSTV picture, this could only be printed in colour. Colour SSTV today is quite an experience to receive, most colour stations transmit extremely high quality pictures which have to be seen to be believed.

Some of the software systems mentioned in this book are very low cost and are capable of producing high quality colour pictures, as an active slow scanner I can vouch for this.

Personally I am very pleased to have this publication in my shack. I wish I had more books on the subject, but they just don't seem to exist. As this aspect of the hobby is, I find, becoming more active with the new and less expensive equipment/software available today, perhaps Mike has now encouraged others to put pen to paper. I certainly hope so, there are so many experienced operators who could impart their knowledge for the benefit of others. I hope those who buy "Slow Scan Television Explained" enjoy reading it as much as I did, and find it a useful addition to their shack.

Pam GWOLAL ... an SSTV addict !

HDTV the Leo Zucker Way

Trevor Brown G8CJS

TV standards are at a cross roads with new systems being proposed every day. In the past we have reported on PAL Plus and Dmac and D2mac, but now from the States comes a proposal for a 525-line NTSC compatible HDTV. The system has been designed and patented by a New York Attorney specialising in patent and trademark law, he is also an Amateur with the callsign K2LZ.

Leo Zucker filed his HDTV system for U.S. patent in February 1990, and the patent no #5,067,017 was granted on November the 19th 1991 and is entitled "Compatible and Spectrum Efficient High Definition Television". The system is 1050-line resolution, and yet is 525-line NTSC compatible and uses only the same 6 MHz of bandwidth that a Standard NTSC channel occupies.

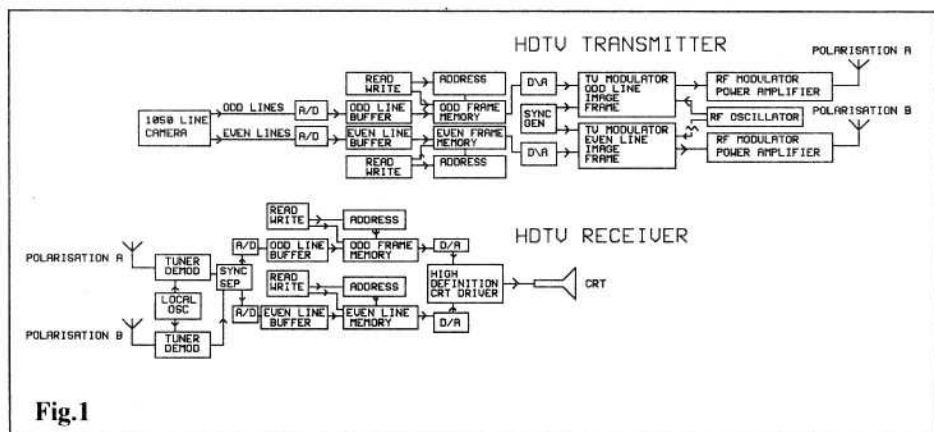

Fig. 1

How does it work? Fig.1 shows the block diagram of the transmitter and encoder, along with receiver and decoder. 1050 lines of video are digitised and pushed into two buffers odd lines into one buffer even into another, thus creating two 525-line frames. The two frames are clocked out of the stores as two simultaneous 525 line pictures. These signals are then modulated onto two carriers, both of the same frequency and originating from the same exciter. The two signals are then fed out to two aerials, one horizontally polarised the other vertically polarised. Existing TV sets will use a single aerial to receive and decode one of the signals. Advanced HDTV sets will receive both signals and interlace them for a 1050-line picture.

Unless I have missed something, this will give you increased vertical resolution and standard horizontal resolution. The aspect ratio will be a standard 5:4, when the world is aiming for 16:9.

The FCC advisory committee chairman Richard Wiley has so far been unable to test the system, due to time slots and the necessary equipment in the ATTC/cable Labs. This has not deterred Leo, who has tested the controversial part of the system on 70cm. Using two orthogonal polarised Cush Craft Yagis and two PC Electronic exciters, to transmit two TV pictures simultaneously on the same frequency. The results were viewed on two high quality colour receivers using synchronous video detectors, and are reported as excellent.

I am sure ATV enthusiasts everywhere wish him luck with his system.

SLOW SCAN TV DOES NOT HAVE TO BE EXPENSIVE ANY MORE!

Pasokon (PAH-SO-CONE) TV is the new full-featured, low-cost alternative. The whole transmit and receive converter is on a single card which slots into your PC! This is the breakthrough that has been waited for for a long time. The basic specifications are:

- * Send and receive all popular modes:
 - Robot Colour: 12, 24, 36, 72 second
 - Robot B&W: 8, 12, 24, 36 second
 - AVT: 24, 90, 94, 188 second
 - Martin: M1, M2, M3, M4
 - Scottie: S 1, S 2, S 3, S4
 - Wraase SC-1: 24,48,96 second.
- * Colour pictures real-time during RX
- * Interface fits inside computer.
- * No machine-dependant timing parameters to set.
- * No extra power supply required.
- * Interface has own crystal oscillator for precise pixel timing.
- * Graphical user interface with mouse support.
- * Does not tie up serial or printer port.
- * On-screen tuning indicator.
- * Read and write popular image file formats: *.GIF, *.PCX, Targa, etc.
- * Full screen images on standard VGA with 320 x 200 256 colour mode.
- * Resolution of 320 x 240 with 32768 colours.
- * 32768 simultaneous colours on super VGA with Sierra IECOLOR RAMDAC.
- * Test pattern generation & image manipulation.

Hardware Requirements:

- * IBM PC/AT or compatible with an empty 8 or 16-bit slot.
- * 286 or later CPU, 640 K memory.
- * VGA display (HiColor option supported).
- * Colour Monitor Mouse strongly recommended.

KIT: £135.00 - Ready-built and tested: £160.00

Post and packing: UK and Europe: £5.00 - Prices include VAT

Designed and developed by John Langner WB2OSZ.

**U.K. and European distributors: KM Publications,
5 Ware Orchard, Barby, Nr.Rugby, CV23 8UF, U.K.
Tel: 0788 890365. Fax: 0788 891883**

MAINLINE ELECTRONICS

The sole suppliers of BATC kits

***'An Amateur who does not construct is only
an operator'***

70cm CONVERTER

as described in 'An Introduction to Amateur Television'

Many people wishing to experiment in television would like to see what's about the band. This unit built to a new design converts the television section of the band up to normal UHF television frequencies. We offer a complete kit of parts including the PCB.

Order No.	Description	Each
BATC01	70 cm Converter	26.75

24cm TELEVISION TRANSMITTER

as described in 'An Introduction to Amateur Television'

There have been several good television transmitters around for some time now. However, with the advent of new technology a more modern design was required. We offer the following latest BATC design 1V pk-pk input 1 Watt output on 24cm. We offer all of the PCB mounted components plus PCB and power module

Order No.	Description	Each
BATC04	24cm Television TX	115.00

All prices plus VAT and p&p. Further details on page-49

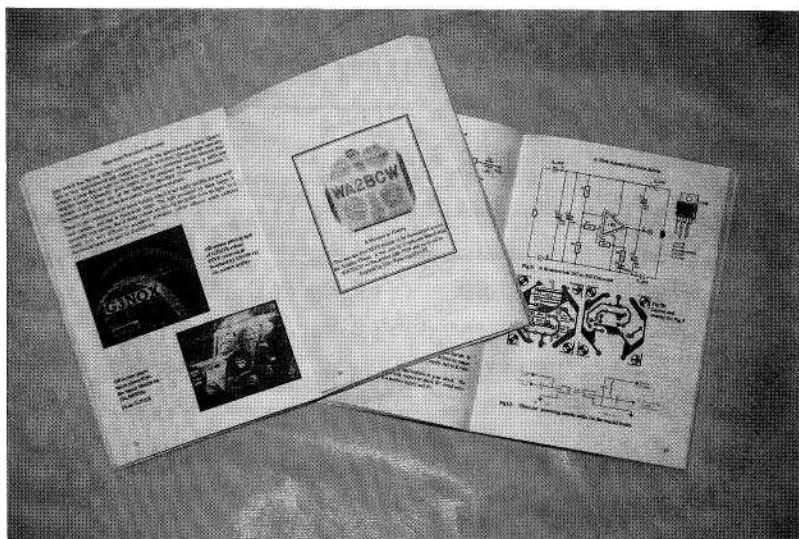
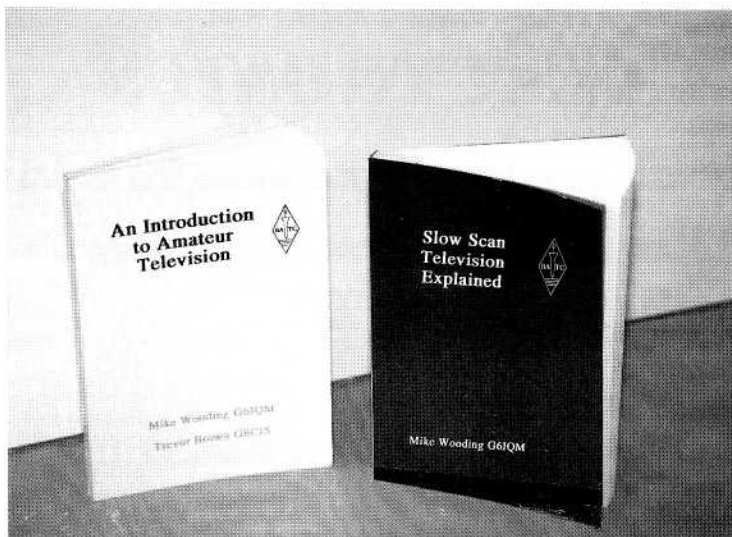

BATC MEMBERS' SERVICES PUBLICATIONS

PUBLICATION	EACH	QTY	TOTAL
AN INTRODUCTION TO AMATEUR TELEVISION (255gm) by Mike Wooding G6IQM & Trevor Brown G8CJS The latest handbook full of detailed information on how to set up your ATV station, plus lots of new video and RF construction projects.	£5.00
SLOW SCAN TELEVISION EXPLAINED (275gm) by Mike Wooding G6IQM The brand new handbook detailing all the information you need to enter the fascinating world of Slow Scan Television: basic principles, explanations of all the modes to date, commercial hardware and computer-based SSTV systems. Also various construction projects for SSTV equipment.	£5.00
			****NEW****
THE AMATEUR TV COMPENDIUM (155gm) by Mike Wooding G6IQM. The latest handbook featuring construction articles on video units, 24cm and 3cm ATV, a Digital Frame Store, and much more.	£3.50
THE BEST OF CQ-TV (150gm) compiled by Mike Wooding G6IQM A compilation of the best construction articles from CQ-TV's 133 to 146.	£3.50
CQ-TV BACK ISSUES: The following issues are still available. Please circle those required: 144, 147, 148, 150, 151 152, 153, 154, 155, 156, 158, 159, 160, 161 <i>Special Offer:</i> any four back issues	£1.50
	£5.00

TOTAL THIS PAGE £.....

PUBLICATION	EACH	QTY	TOTAL
INDEX (40gm)			
All main articles in past issues of CQ-TV and seven Handbooks. Including page count, (essential for ordering re-prints)	£1.00

RE-PRINTS.

Photocopies of any article from past publications are available. Please quote the issue number, page numbers and the article name. Discounts as shown, prices are per sheet:

1 to 5 sheets.....	£0.25
6 to 10 sheets.....	£0.20
11 to 20 sheets.....	£0.15
21 sheets and above.....	£0.10

CQ-TV BINDERS	£3.50
----------------------	-------	-------	-------

TOTAL GOODS THIS PAGE	£.....
TOTAL FROM PREVIOUS PAGE	£.....
EXTRA POSTAGE (overseas members only)	£.....
TOTAL ENCLOSED**	£.....

****PLEASE MAKE CHEQUES PAYABLE TO: BATC.**

The above prices include postage within the EEC. Will members outside the EEC please either try to estimate the extra postage required, or write for a quotation. All cheques **MUST** be drawn on a U.K. bank. (Eurocheques are acceptable). Send orders for publications **ONLY** to: **BATC PUBLICATIONS, 14 LILAC AVENUE, LEICESTER, LE5 1FN, ENGLAND**

name:	mem no:	callsign:
address:		
country:	zip/post code:	

MEMBERS' SERVICES

Items from these lists can **ONLY** be supplied to **CURRENT** members of the **BATC**.
These lists supercede all previous ones.

We reserve the right to change prices without notice.

QTY	CAMERA TUBES, SCAN COILS, BASES & LENS MOUNTS	EACH £	P&P £	TOT £
1	One inch vidicon scan coils	6.00	1.40
2	2/3 inch vidicon scan coils	6.00	0.90
3	One inch vidicon base	1.00	0.27
4	2/3 inch vidicon base	0.65	0.27
5	C-mount for lens	P.O.A	0.27
6	Camera tube type	P.O.A	1.00

QTY	VIDEO CIRCUIT BOARDS/COMPONENTS	EACH	P&P	TOT
7	ZNA134 sync pulse generator PCB**	3.00	0.38
8	2.5625 MHz crystal	2.75	0.27
11	Character generator PCB	4.00	0.38
12	Teletext pattern PCB	3.00	0.38
82	Monochrome pattern PCB	2.00	0.27
13	Greyscale/colourbar generator PCB	3.00	0.38
14	Colour test card PCB set	15.00	0.65
15	TBP2BL22 circle program PROM	10.00	0.27
16	PAL colour coder PCB	6.00	0.38
17	Character colouriser PCB	5.00	0.38
18	TEA2000 colour coder PCB	2.00	0.27
19	Video filter PCB	1.00	0.27
20	Video processing amplifier PCB	4.00	0.38
26	Video level indicator PCB	5.00	0.38

TOTAL GOODS THIS PAGE £.....

QTY	VIDEO CIRCUIT BOARDS/COMPONENTS	EACH £	P&P £	TOT £
21 Vision switcher matrix PCB	4.00	0.38
22 Vision switcher logic PCB	4.00	0.38
23 Vision mix effects amplifier PCB	4.00	0.38
24 Wipe effect generator PCB	3.00	0.38
25 4 input TEA5114 vision select PCB	3.00	0.38
27 A - D and D - A converter PCB	5.00	0.38
28 Digital video read address PCB	5.00	0.38
29 Digital video write address PCB	5.00	0.38
30 Digital video RAM PCB	4.00	0.38
31 Digital video backplane PCB	6.00	0.38
32 UVC3130-09 A-D and D-A IC	40.00	0.27
33 Spectrum user port PCB	3.00	0.38
34 Spectrum prom blower PCB	3.00	0.38
35 FLEX prom blower PCB	5.00	0.38
40 I ² C CPU PCB	7.50	0.38
41 I ² C VDU PCB	7.50	0.38
81 I ² C 27256 EPROM (quote membshp no.)	8.25	0.27
42 13.875 MHz crystal	4.00	0.27
43 SAA5231 genlock IC	6.50	0.27
44 SAA5243PE Teletext IC	11.50	0.27
45 PCF8583 clock IC	6.00	0.27
10 I ² C relay PCB	5.50	0.38
9 PCF8574A Input expander IC	4.00	0.38
36 I ² C video switch PCB	7.50	0.38
37 GX414 video switch IC	7.50	0.27
38 PCF8574P input expander IC	3.00	0.27
39 LM1881N 5sync separator IC	3.00	0.27

TOTAL GOODS THIS PAGE £.....

QTY	RX, TX AND SSTV PCBS/COMPONENTS	EACH	P&P	TOT
		£	£	£
46 4 rail power supplies PCB	3.00	0.38
47 70cm downconverter PCB	P.O.A	0.27
49 70cm DSB transmitter PCB**	3.00	0.38
83 70cm ATV transmitter PCB	P.O.A	0.38
50 108.875 MHz crystal	7.00	0.27
51 ATV up converter PCB**	2.25	0.27
52 Amateur television AM IF PCB	1.50	0.27
53 FM TV demodulator PCB	3.00	0.38
54 24cm GaAsFET converter PCB	3.50	0.38
84 24cm ATV receiver PCB	P.O.A	0.38
87 ASTEC AT2320V module	50.00	0.90
88 XR215 phase lock loop IC	3.00	0.27
85 24cm ATV transmitter PCB	P.O.A	0.38
86 24cm solid state amplifier PCB	P.O.A	0.38
55 Gunn diode modulator PCB	2.50	0.27
56 10GHz head unit PCB set	2.50	0.27
57 Tunable if PCB	2.50	0.27
58 6MHz audio subcarrier generator PCB	1.50	0.27
59 G3WCY SSTV scan converter PCB set	10.00	0.65
60 G4ENA colour etc. SSTV mods PCB set	5.00	0.38
61 G4ENA SSTV transmit mod to WCY PCB	6.00	0.38
62 G4ENA auxiliary PCB	2.00	0.27
63 SSTV sync and pattern gen PCB	3.00	0.38
64 SSTV spg/pattern 2732 EPROM	12.00	0.27
65 MC1445 gated video amplifier IC	3.50	0.27
66 TEA2014 video switch IC	1.10	0.27
67 TEA5114 video switch IC	1.50	0.27

TOTAL GOODS THIS PAGE £.....

QTY	STATIONERY & STATION ACCESSORIES	EACH	P&P	TOT
		£	£	£
48 13.14 MHz crystal	5.00	0.27
68 4.433618 MHz crystal	2.75	0.27
69 5.0 MHz crystal	2.75	0.27
70 6.0 MHz Teletext crystal	1.50	0.27
71 BATC diamond buttonhole badge	0.40	0.27
72 BATC round lapel badge	0.50	0.27
73 BATC blue diamond clutchpin badge	1.50	0.27
74 BATC key fob	0.75	0.27
75 BATC round equipment sticker	0.15	0.27
76 BATC square windscreen sticker	0.10	0.27
77 Set of ferrite cores for VSB TX	0.20	0.27

ZERO RATE VAT ITEMS

78 BATC test card	0.50	0.38
79 BATC reporting chart	0.12	0.38

TOTAL GOODS THIS PAGE	£.....
TOTAL GOODS FROM PREVIOUS PAGES	£.....
ADD POSTAGE	£.....
TOTAL GOODS AND POST	£.....
UK MEMBERS ADD VAT (17.5% OF GOODS AND POST)	£.....
TOTAL AMOUNT ENCLOSED	£.....

Items marked thus: ** are available only until present stocks are exhausted.

ORDERS PLEASE TO: Mr. P.Delaney. 6 East View Close, Wargrave, BERKS RG10 BBJ, England. Tel: 0734 403121 (evenings/weekends only please).

name:	mem no:	callsign:
address:		
country:	zip/post code:	

We reserve the right to change prices without notice.

MEMBERS SERVICES ORDERS PLEASE TO: Mr. P. Delaney, 6 East View Close, Wargrave, BERKS RG10 BBJ, England. Tel: 0734 403121 (evenings/weekends only please). BATC Members Services does not hold stocks of BATC publications, and vice versa. **OVERSEAS MEMBERS** should ask for a quotation of postage costs and acceptable forms of payment **BEFORE** ordering from Members Services. Please enclose an International Reply Coupon for reply. **CHEQUES** should be made payable to 'BATC' and should be for British banks only please, in pounds sterling.

MEMBERS SERVICES Items from these lists can **ONLY** be supplied to **CURRENT** members of the **BATC**. Please note that **ONLY** the items listed in the **CURRENT** 'Services for Members' leaflet are available - a description of most the various PCBs and components can be found, in the 'What's What' supplement sent with CQ-TV 149. Components for club projects are not available from Members Services unless contained within these lists. All Club crystals are HCLB/U (wire ended). Items marked thus: ** are available only until present stocks are exhausted. To avoid delay and inconvenience, please be careful to include the correct amount of VAT with your order, ie 17.5% of total goods **AND** postage, unless an overseas member. Payment should be by cheque or crossed postal order in favour of BATC - do NOT send cash or stamps please.

VIDICONS

1'' vidicon tubes are available in different heater ratings (95 and 300mA) - 6'' long; (EMI types 9677, 972B and EEV types P849). 2/3'' tubes have 95mA heaters (EEV type P8037). These tubes are all of separate mesh construction, with magnetic focus. Tubes available to special order include electrostatic focus or deflection, and low light types not previously available to club members. Prices vary depending on the size, type and grade of tube. A tube guide appears in CO TV 149 and 150. Please contact Members Services for further information. The stripe filter tubes used in domestic type colour cameras are not available through BATC, and normally must be ordered direct from equipment supplier. Members requesting information on prices or other types of tube or equivalents are asked to send a stamped, addressed envelope for their reply.

COMPONENT SUPPLIES

Some members have found difficulty locating various components used in club projects. The following may be found helpful:

Sendz Components, 63 Bishopsteignton, Shoeburyness, Essex, SS3 BAF Manor Supplies, 172 West End Lane, London NW6 1SD Grandata, KP House, Unit 15 Pop In Commercial Centre, Southway, Wembley, Midlx Economic Devices, PO Box 15, Wolverhampton, WV2 4AZ Marapet, 1 Hornbeam Mews, LongIL-vens, Gloucester, GL2 OUE

The first 2 firms specialise in surplus TV components and panels, and are an invaluable source for the experimenter. The last 3 firms both keep a wide range of semiconductors with special TV uses.

WHO TO WRITE TO

Members of the BATC Committee are available to help and advise Club members on any ATV related subject. Please remember that all Club work is done in spare time, so please try to keep such queries to a minimum.

CQ-TV MAGAZINE - Anything destined for publication in CQ-TV or forthcoming publications; articles; review items; advertisements; other material. EDITOR: MIKE WOODING G6IQM, 5 Ware Orchard, Barby, Nr.Rugby, Warwickshire, CV23 8UF. Tel: 0788 890365 (Answerphone); Fax: 0788 891883.

CLUB AFFAIRS - Video tape library; technical queries, especially related to Handbook projects: TREVOR BROWN G8CJS, 14 Stairfoot Close, Adel, Leeds, LS16 8JR. Tel: 0532 670115.

MEMBERS' SERVICES - PCB's; components; camera tubes; accessories; etc., (other than publications). PETER DELANEY G8KZG, 6 East View Close, Wargrave, Berkshire, RG10 8BJ. Tel: 0734 403121.

MEMBERSHIP - Anything to do with membership, including new applications; queries and information about new and existing membership; non-receipt of CQ-TV; subscriptions; membership records; data protection. DAVE LAWTON G0ANO, 'Grenehurst', Pinewood Road, High Wycombe, Bucks., HP12 4DD. Tel: 0494 528899.

GENERAL CLUB CORRESPONDENCE & LIBRARY - Any general Club business. Queries relating to the borrowing or donation of written material. PAUL MARSHALL G8MJW, Fern House, Church Road, Harby, Nottinghamshire, NG23 7ED. Tel: 0522 703348.

PUBLICATIONS - Anything related to the supply of BATC publications. IAN PAWSON G8IQU, 14 lilac Avenue, Leicester, LE5 1FN. Tel: 0533 769425.

EXHIBITIONS & RALLIES - Also arrangements and information about lectures and talks to clubs; demonstrations, etc. PAUL MARSHALL G8MJW (address above).

CLUB LIAISON - And anything of a political nature; co-ordination of ATV repeater licences. GRAHAM SHIRVILLE G3VZV, The Hill farm, Potsgrove, Milton Keynes, Buckinghamshire., MK17 9HF. TEL: 0525 290 343.

CONTESTS - RICHARD GUTTRIDGE G4YTV, Ivy House, Rise Road, Skirlaugh, Hull, North Humberside, HU11 5BH. Tel: 0964 562498.

CQ-TV AWARDS - BOB WEBB G8VBA, 78 Station Road, Rolleston-on-Dove, Burton-on-Trent, Staffordshire., DE13 9AB. Tel: 0283 814582

Where possible, it is better to telephone your query rather than write. Please do not call at unsocial hours. As a guide, try to call between 1830 and 2130, and not before 1130 at weekends ... Thank you.

THE NEW BATC BOOKS

AN INTRODUCTION TO AMATEUR TELEVISION

SLOW SCAN TELEVISION EXPLAINED

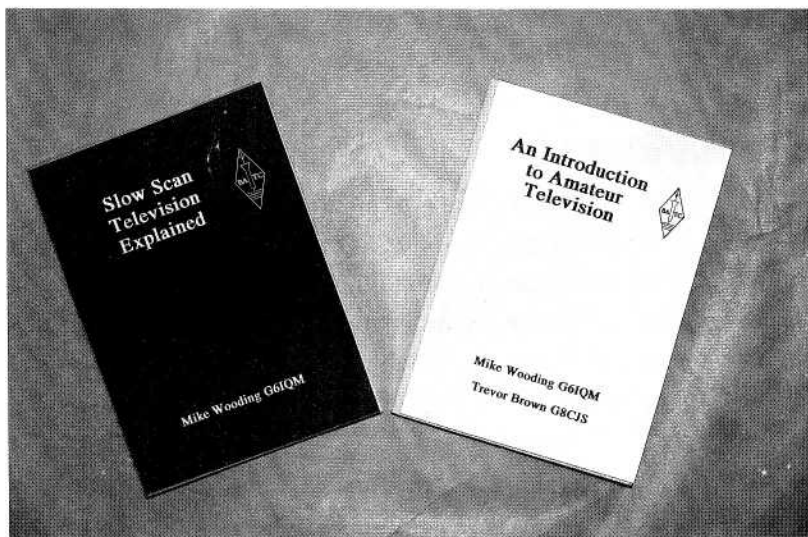

£5.00 EACH (INC POSTAGE)

OR

***SPECIAL OFFER EXTENDED UNTIL
31st MARCH***

£9.00 THE PAIR (INC POSTAGE)

MAINLINE ELECTRONICS

70cm TRANSMITTER

as described in 'An Introduction to Amateur Television'

A modern filtered television transmitter, crystal controlled 5 Watts output with a video clamp and using MMIC ICs. The unit comes complete with a crystal and printed plated through board.

Order No.	Description	Each
BATC02	70cm Transmitter	86.00

24cm LINEAR KIT

as described in 'An Introduction to Amateur Television'

Similar to our straight PCB this unit offers a complete kit of parts for constructing an ATV or SSB linear at about 15 Watts using a M57762. Suitable heatsinks can be found in our main catalogue. The kit offers a saving from buying the parts separately. requires 500-700mW of drive. Hardware, fan and cables are not included.

Order No.	Description	Each
BATC03	1296 MHz Linear Kit	67.23

9 / 13 / 23cm LOOP YAGI AERIALS

Designed by G3JVL, these loop Yagis are built to very rugged standards with stainless steel loops and aluminium booms. All aerials are supplied with fully assembled and tested driven elements. Being slightly wideband the whole of the band allocation can normally be covered. See our catalogue for the full range. The range includes:

23cm - 28 element ... £65.00 * 23cm - 48 element ... £95.00

MAINLINE ELECTRONICS, P.O. Box 235, Leicester, LE2 9SH
Tel: 0533 777648/780891 Fax: 0533 477551

A BEGINNERS GUIDE TO SSTV

Those of you who know Pam will be aware of her tremendous enthusiasm for Slow Scan TV and her willingness to help any and all who ask her for help and advice on the mode. The following article is essentially the paperwork that Pam produces and sends out to those who contact her with questions concerning SSTV, and I consider it well-worth reproducing here as a valuable source of information, some of which I have to admit is not in my new book ! ... Mike

Pam C. Penlington GW0LAL

HELLO FROM GW0LAL

This guide is basically a list of available equipment and SSTV modes/speeds found on the Amateur frequencies. Any technical or in depth information is not included. My intention is to help people who would like to try slowscan, but do not know which equipment is available, or the speeds/modes it is capable of transmitting. It is gleaned from my personal knowledge and information received. I am constantly adding to the list as and when information is available. If anyone reading this can supply me with extra facts I will be very grateful.

Information and help can always be acquired from any of the SSTV nets found on the bands. The majority of slowscan stations are helpful and patient with newcomers to this beautiful mode.

Apologies in advance for my lack of grammatical flair, or errors in the listing, the facts are hopefully accurate.

I have included a few sample pictures so that you have some idea of the variety of picture content found on the bands. Due to hard drive space most of the pictures are my own, but I have included a few that I have received on air via the SSTV mode from other people. My pictures are full colour and generally I would transmit them in the M1 or S1 high resolution mode. To capture them for SSTV use I use the following method:

First and foremost is acquiring the necessary material, either calendars, children's books, postcards or magazines, etc. In fact any printed material that I can find.



From time-to-time I use live shots of my shack, family, or self, and during the summer months I go out and about with my video camera taking film of any interesting subject. The camera I use is a JVC S707 Camcorder, which also comes in handy for family use apart from the hobby. My SSTV scan converter is a Robot 1200c and for lighting I have several methods:

- 1) A Halogen 500W floodlight (the type used externally for garden use). This I find useful for lighting a large area, e.g: for taking shots of the shack or equipment,
- 2) A 120W Tungsten floodlamp,
- 3) A Halogen 150W bulb in an Anglepoise lamp,
- 4) A 100W Xenophot HXL 12 volt bulb with a compromise adaptation mounted in an Anglepoise lamp. This is a very small bulb, but gives a very good light for lighting up printed material, calendars, etc.

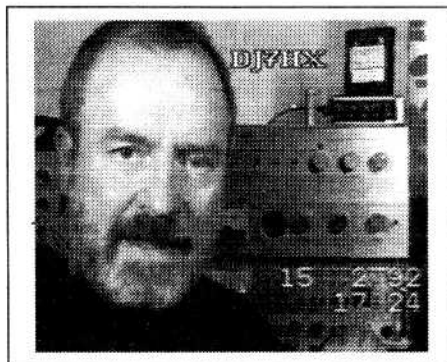

I can plug the video output from my camera directly into the Robot 1200c unit and monitor whilst I set up the lighting, then it is merely a case of pressing one button on the 1200c and I have a captured picture. This I can then save to computer disc.

I sometimes use a small video enhancer in-line between the camera and 1200c, which gives me more control over the video level and sharpness. The picture, once saved to disc, can be recalled any

time for transmission, or I can firstly, via software, add some text or a border, etc., to it. I generally spend more time preparing my SSTV pictures than I actually spend on air transmitting them, and I am usually on air most days!

The samples reproduced here were reduced down to 256 greyscale using computer software, the original colour version is really a different world. I do mainly work in colour, but admire some of the stations that produce excellent quality B&W SSTV pictures. As with photography, it is an art itself.

WHERE TO FIND SSTV

3.730 ± QRM ... lsb (Most Sunday mornings 11.30 + conditions allowing and some evenings mainly colour transmissions in M1 mode)

7.042 ± QRM ... lsb (Most weekday afternoons ... QRN/QRM being a problem mainly colour transmissions sometimes B&W if requested)

14.230 ± QRM ... usb (Very active band if propagation is OK ... all modes)

21.340 ± QRM ... usb (Rarely used which is a shame)

28.680 ± QRM ... usb (Very popular when open)

144.500 ... FM (Very active in some parts of the UK)

All modes of SSTV are permitted on any of the above bands ... the mode used is merely governed by the stations who meet up and the equipment they have.

Fax can also be found ... on 14.230 ± and to a newcomer could be mistaken as SSTV. With experience the modes and speeds can be identified by ear, also some SSTV equipment has it's own individual sound. A Robot sounds slightly different to an Amiga or SC2 transmission.



Other bands can be used, but as I don't use them I am not familiar with the recommended frequencies.

There is some question at the moment as to the availability of the Robot 1200c. Robot Research no longer have Worldwide agents. Some say they are still producing 1200c's.

When buying a new Robot it only has modes up to 72 second colour, details of modifications to bring it up to all modes are available from Martin Emmerson G30QD.

ORDERING EQUIPMENT / SOFTWARE

When placing an order for software always give full details of the computer you intend to run it on e.g: Model & make / Video display type / Memory / Speed and Drives.

When ordering from abroad always check that the system is suitable for the British power supply and the PAL system.

I am not prepared to quote prices but as a guide line the dedicated units are the top of the range and are priced accordingly. Home constructed units come next and are good value for those with the ability. Computer stand-alone systems are the cheapest if you already own the appropriate computer. Some of the software is very good depending on the resolution you find acceptable.

ACQUIRING PICTURE MATERIAL FOR TRANSMISSION

Dedicated units ... Robots and Robot clones / SC1&2 ... have a camera input socket and a computer is not necessary. (Video camera / B&W surveillance type camera or video output from VCR). If a B&W camera is used for colour pictures red, green and blue filters are necessary and the R, G and B individually captured to form a colour picture. Some of the units can be interfaced to a computer, which can be used to store pictures and advantage can be taken of graphic/art software.

Alternately, pictures can be stored on a VCR tape or a good quality audio cassette, with either of these two options expect some deterioration of the stored picture. Pictures saved to computer disk are saved and loaded back maintaining all the original quality. Less convenient is to capture a picture live whilst on air.

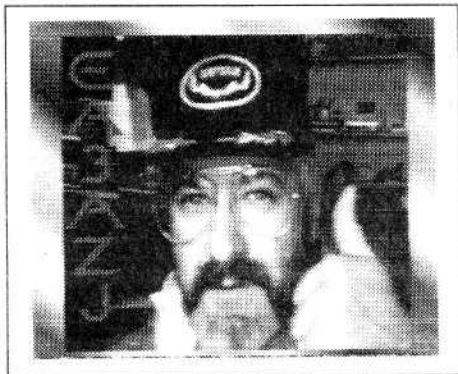

For computer SSTV software systems, either computer graphics can be used, or it is necessary to have a digitiser board for the computer in order to use a camera ... possibly a hand scanner can be implemented ... or received pictures can be retransmitted with a replay message on them.

The subject matter is a question of individual taste and material available. Picture content is extremely varied, ranging from self portrait and shack pictures,

to artistic graphic compositions. Scenery, animals, vehicles and flowers are used, also cartoons and fun pictures. Some stations concentrate on quality and resolution, others on interesting picture content, to achieve both is the ultimate. An active slowscanner is constantly looking for new material. With B&W SSTV the aim is to get sharp pictures with good grey scales ranging from black to white. Lighting is not too critical to achieve good results. When capturing a colour picture for transmission, lighting is more important, the aim being to get good colour saturation and resolution. Personally, I find natural skin tones the most difficult to achieve.

It is not my intention to recommend any particular equipment, readers must make his / her own choice. The choice depends on partly finances and how deeply one wishes to become involved in slowscan. If you know anyone who is active in this field then it would be advisable to have a chat with them before making any purchases.

AVAILABLE BOOK ...

SLOW SCAN TELEVISION EXPLAINED by Mike Wooding G61QM. available from BATC Publications, 14 Lilac Avenue, Leicester, LE5 1FN.

GROUPS to join ..

IVCA 101 Oenoke Lane, New Canaan,
CT 06840, USA

BATC "Grenchurst", Pinewood Road,
High Wycombe, Bucks, HP12 4DD UK

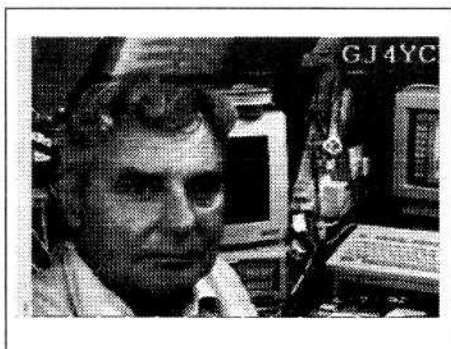

AVAILABLE EQUIPMENT

ROBOT 1200c

MOST popular, used worldwide and compatible with all modes. Colour and B&W. Kept up to date with all modes by Martin G30QD developing and supplying new EPROMs on a regular basis as necessary. Colour and B&W. Computer not necessary but Software and interface available for PC clone/BBC/Commodore and Amiga (the PC being the best) in order to save/load pictures and enhance pictures. This unit I have and can thoroughly recommend it as excellent and, I believe, the best. Below are listed available boards for those who wish to build their own.

SUPERSCAN 2001

Home Brew Scan converter with some advanced features beyond the Robot 1200c. (boards and EPROM + list of parts). Available approx. September 92, should be very popular. Same modes as Robot 1200c. (SAE to G30QD for full information). Computer not necessary, but software and interface available as for Robot 1200c. This will be excellent and certainly worth seriously considering. G30QD and friend have implemented some features beyond the Robot 1200c.

LM9000 (VK3LM)

Robot 1200c compatible boards for home construction. Computer not necessary, but software and interface available as for Robot 1200c.

RIBBET (VE3DUO)

Robot 1200C compatible boards for home construction. Computer not necessary, but software and interface available as for Robot 1200C.

NS-88 (JF3GOH)

Robot 1200c compatible boards for home construction. Computer not necessary, but software and interface available as for Robot 1200c.

ROBOT 450c

Very few used now. Similar in appearance to the 1200c, but no modifications available for very high resolution modes. Colour and B&W, highest resolution = 72 sec colour. Computer not necessary, interface and software availability ? possibly same as 1200c. I have worked a few stations with the 450c and received very good

pictures, but feel it would be unwise to purchase one because of not being able to update it to modern high resolution modes.

ROBOT 300 & 400

Was very popular and still in use. 8 sec B&W only, some with 16 sec. Computer not necessary, no known software or interface for computer. I have worked stations with the 400 received pictures were very nice. But no updates to other modes possible.

ROBOT 400C & 450C

Upgrade of the 400 with ability to TX/RX colour and can be interfaced to the Robot 800 keyboard. I have never worked a station with this unit, but it's not high resolution, nor is it possible to update.

ROBOT 800 / 800C

These are multimode keyboard units, (ASCII, CW, SSTV), SSTV is TX only, the intention being to use with all the above units (not 300 or 400) for text generation.

VOLKER WRAASE SC1 (DL2RZ Equipment)

Older model common in Germany and some stations in UK compatible with Volker Wraase modes only, highest resolution being 96 sec and FAX. Computer not necessary, no interface or software available. I have worked many stations using the SC1 and had some nice pictures from them, quite a number of SC1 owners are changing to the SC2. Optional keyboard available for SC1 and SC2.

VOLKER WRAASE SC2 (DL2RZ)

Mainly Germany and gaining in popularity. Compatible with all Volker Wraase modes and FAX M1 and S1 (not AVT), 60 sec and 120 sec.. Available from DL2LZ. Computer not necessary, but software and interface available from Volker Wraase for the Amiga computer. Software and Interface for IBM PC available January 1993.

DK7BO unit; RX only at the moment.

Gaining in popularity mainly Germany. Available from DK3BO. RX all SC1 modes / M1 AND S1. Interfaces to IBM clone computer. A few TX prototypes (home brew) being used in Germany. I have worked stations with the prototype TX unit and received excellent M1 pics.

DRAE UNIT

B&W 8 sec TX/RX only. Some in use. Available Amateur suppliers. I have only worked one station with this unit OK for 8 sec B&W low resolution.



DFM-USA UNIT

Colour and B&W. Compatible with most current SSTV systems. No details yet, information available from K8SQL or AB4QC.

MFJ multimode Unit

Colour and B&W ... TX/RX 8, 12, 24, 36 B&W; 72, M1, M2, S1, S2 Colour.

AMIGA COMPUTER ... Very popular worldwide

AVT system available from Advanced Electronic Applications (USA) and possibly from ICS (UK) All modes and Fax. DF51R software and interface. Volker Wraase modes + M1 & M2. C-DATA software + Interface. Volker Wraase modes, M1, M2, S1 + S2.

PC COMPUTER ... Several stations in USA now using PC software.

VIEWPORT VGA ... Colour and B&W (KA2PYJ),

RX: 8/12/24/16/72/M1/M2/S1/S2. TX: 8/12/24/36/72/S1.

32K Hires video card advantage, but not essential. Interface unit, or 2 kit + software, available from A & A Engineering.

PASOKON TV ... Colour and B/W (WB20SZ),

All modes/speeds TX/RX.

32kHires video board advantage but not essential. Available from John Langner WB20SZ and KM Publications.

SSTV FAX ... B&W, (ON5KN) + simple interface details. Available via Packet.

KINNEY SOFTWARE ... (No details yet)

SOFTWARE CONSULTING GROUP ... (Most modes B/W + Colour)

BMK MULTIMODE ... No details, believed to be low res B&W

JVFAX V5 (FAX/SSTV) ... TX/RX Fax / RX SSTV. Few basic modes.

KIUTI ... IBM/MFJ-1278 Colour. Software to use with this unit / no details.

MULTISCAN ... Colour and B&W = Fax (PEIKSW/CombiTech)

RX: 7.2/8/16/32/24/48/96; TX: 7.2/8/16/32

ARCHIMEDES COMPUTER Colour and B&W

RX: M1,M2,S1,S2,AVT90,AVT94,8,16,32,B/W.

TX ... M1,M2,(adding 8,16,32 soon).

Details available. SAE + £1 from G41JE.

BBC COMPUTER

A few stations, reasonable for B&W, but poor on colour. Compatible Volker Wraase modes and standard Robot 1200c modes. Not Martin/Scottie or AVT. I have worked a couple of stations with this system and found the colour on computer generated graphics only acceptable, retransmitted colour pictures were extremely poor, B&W was better. Details available from Technical Software.

ATARI COMPUTER

WA20SZ ... Colour, TX/RX all modes VE2BNC ... Colour, TX/RX, no details
KC5FW ... B&W, Colour?, no details.

SPECTRUM COMPUTER

GIFTU SOFTWARE ... TX colour and B&W, RX in B&W only.

RX SOFTWARE from Technical Software ... Due to the low memory of a Spectrum high resolution SSTV is not possible.

DRAGON 32 / 64, TRS-80 COMPUTER

No details available but believe software available from G4BMK.

COMMODORE VIC-20 AND CBM64

RX only B&W Software Available from Technical Software, Upper Llandwrog, Caernarvon, N.Wales.

B&W low resolution software believed available for: TS-80 and Tandy Coco. No address, most likely in the USA. Various other B&W low res systems. No details known.

MODES ... SPEEDS OF TX/RX

Most common modes heard on the bands

B&W: 8/16/32 Colour: 96/M1/S1/72/36/AVT.90/96

VOLKER WRAASE (DL2RZ) or European mode ... mainly used in Europe.

B&W: 8 sec / 12 sec / 24 sec / 36 sec; Colour: 24 sec / 24 sec / 36 sec / 60 sec 96 sec / 120 sec

ROBOT 1200c mode ... USA modes ... used worldwide.

B&W: 8 sec / 12 sec / 24 sec / 36 sec; Colour: 12 sec / 24 sec / 36 sec / 72 sec

MARTIN mode (G30QD) ... used worldwide.

M1 Colour (highest res 120 sec to TX) commonly used in Europe.

M2 Colour (high res) rarely used.

M3 and M4 colour (lower res) never used.

SCOTTIE mode (GM3SBC) ... used worldwide.

S1 colour (highest res 115 sec to TX) Favoured by USA/JA/ZS/VK and ZL

S2 colour (high res) rarely used.

S3 and S4 colour (lower res) never used

Scottie DX colour (very high res) 3 mins to TX generally used between VK/ZL or ZS when in contact with USA.

AVT modes / AMIGA Computer ... used USA and Europe.

Most owners of Robot 1200c have had modifications to their units to RX/TX these modes. AVT 188 sec colour (highest res) sometimes used AVT 96 sec colour (high res) Amiga users favourite AVT 90 sec colour (high res) commonly used generally AVT 125 sec B&W (high res) These are the modes I have on my Robot 1200C. I think there may be more on the Amiga.

USEFUL ADDRESSES

ROBOT RESEARCH CORPORATION, 5636 Ruffin Road, San Diego, CA92123 USA

I/O CARD (to interface Robot 1200 and clones to an IBM/MS DOS computer): Martin Emmerson G30QD 6 Mounthurst Road Hayes Bromley Kent BR2 7QN Tel: 081 462 -4223.

Other sources..... Metra byte P10-12 card from: MetraByte Corporation 440 Myles Stanish Blvd. Taunton, MA 02780 USA; or Metra Byte P10-12 card from: Keithley Instruments Ltd. 1/3 Boulton Road, Reading, RG2 7BR. (Also from VE3DUO)

MARTIN EPROM (M1,M2,S1,S2,DX and AVT modes): Martin Emmerson G30QD 6 Mounthurst Road, Hayes, Bromley, Kent, BR2 7QN. Tel: 081 462 4223

SCOTTIE EPROM (S1,S2 and DX modes): E.Murphy GM3SBC, 65 Silverknowes Crescent, Edinburgh, EH4 5JA.

SUPERSCAN 2001: Jad Bashour, 55 Brampton Road, London, N15 3SX. Tel: 081 809 3911; or Martin Emmerson G30QD, S.A.E for info.

RIBBET SCAN CONVERTER BOARDS (Robot 1200c compatible boards) B.Summers VE3DUO, 336 Gododram Drive, Burlington, Ontario, Canada, L7L 2K1.

LM-9000 SCAN CONVERTER BOARDS (Robot 1200c compatible boards) J.Wilson VK3LM, R.M.B.4201A, Tallangatta Valley, 3701 Australia.

CQ-TV 161

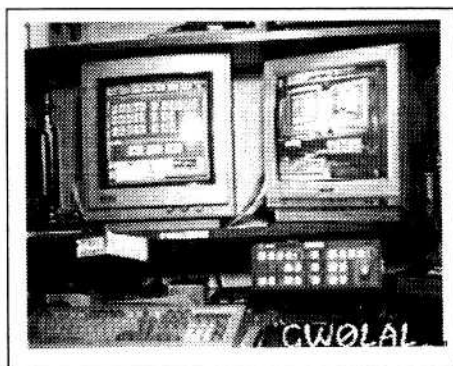

NS-88 SCAN CONVERTER BOARDS (Robot 1200c compatible boards):
M.Yamafuzi JF3GOH, P.O. Box 670, OSAKA, 531 Japan.

SC1 and SC2: Volker Wraase DL2RZ, Wraase Eleckronik, Kronsberg 10, D-2300 Altenholz, Germany.

DK7BO RX SYSTEM: Werner Statmann DK7BO, Middelreeg 22, D-2933, Jade 1, Germany

DFM-USA: K8SQL, 265 Outlook, Youngstown, Ohio 44504-1846 USA; or AB4QC 3575 Shadywoods Circle, Lawrenceville, Georgia, 30244 USA.

MFJ Enterprises Inc. (Slowscan Unit Boards and EPROM + instruct.): Box 494, Miss. State, MS 39762 USA

MS/DOS SOFTWARE for Robot 1200c

HIRES: T.Jenkins N9AMR, 5968 South Keystone Ave, Indianapolis, IN 46227 USA.

GESTI: Torontel Technology Systems Ltd., 94 Sackville Street, Suite A, Toronto Ontario, Canada, M5A 3EJ.

SCAN: Bert Beyt W5ZR, 301 Tampico Street, New Iberia, LA 70560, USA.

SSTV by KC5VC: Garnett Bebermeyer WB0UNB, 15 Almeda Court, Fenton, MO 63026, USA.

IMAGE: George Isley WD9GIG, 746 Fellows Street, St.Charles, IL 60174, USA.

also: P.Mescalchin I3XQW, Via Monte 1, I-35100, Padova, Italy.

AMIGA & COMMODORE SOFTWARE for 1200c: T.Hibben KB9MC, Mule Hollow Road, Box 188 DeSoto, WI 54624, USA.

BBC SOFTWARE for 1200c: P. Turner G41JE, 61 Primley Lane, Sheering, Bishops Stortford, CM22 7NH.

COMPUTER STAND ALONE SOFTWARE SYSTEMS

IBM MS DOS COLOUR; "Pasokon TV": J.Langer WA20SZ, 115 Stedman Street Chelmsford, MA 01824, USA. European Agent: KM Publications, 5 Ware Orchard Barby, Nr.Rugby, Warwickshire, CV23 8UF, UK.

IBM MS DOS COLOUR; "Viewport VGA": A & A Engineering, 2521 West LaPalma, Unit K, Anaheim, CA 92801, USA.

C-64 / C-128 / IBM MS DOS / TANDY: Kinney Software, 974 Hodson Road Pownel, ME 04069, USA.



IBM MS DOS COLOUR; Software Consulting Group, 1303 South Ola Vista, San Clements, CA 92672, USA.

IBM MS DOS COLOUR + FAX; CombiTech, Morelstraat 60, 3235 EL Rockanje The Netherlands.

IBM / MFJ-128 COLOUR; John Tuttle K1UTI, Barrington, NH 03825, USA.

IBM MS DOS "Jvfax V5"; E.Backeshoff DK8VJ, Obschwarzbach 40A, D-4020 Mettmann, Germany.

ATARI COLOUR; J.Langer WA20SZ, 115 Stedman Street, Chelmsford, MA 01824 USA.

ATARI COLOUR; R.Gendron VE2BNC, 315 6025 Croissant Brodeur, Brossard Longueuil, Quebec, Canada, J4Z 1YT.

ATARI COLOUR ??; J.Adams KC5FW, 17106 Happy Hollow, San Antonio, TX 78232, USA.

AMIGA COLOUR (SSTV + FAX); Advanced Electronic Applications Inc., P.O. Box C2160, 2006 196th Street, S.W. Lynwood, WA 98036, USA.

AMIGA COLOUR (SSTV + FAX); K.D.Gerber DF51R, Gutacherrin 23, Mannheim 6800, Germany.

AMIGA COLOUR; C-Data, 8068 Pfaffenhofen/Im, Hohenwarter Str. 6, Germany.

ARCHIMEDES COLOUR; P.Turner G41JE, 61 Primley Lane, Sheering, Bishops Stortford, CM22 7NH, UK. (S.A.E + £1 for Demo disk & details)

BBC / COMMODORE / SPECTRUM / VIC20 & CMB64; Technical Software Upper Llandwrog, Caernarvon, Wales.

SPECTRUM; J. Pearson G1FTU, 42 Chesterfield Road, Barlborough, Chesterfield Derbyshire, S43 4T7.

DRAGON 32/64 / TRS-80 / IBM MS DOS; Grosvenor Software, G4BMK 2 Beacons Close, Seaford, Sussex, BN25 2JZ.

Pam C.Penlington, 7 Thornley Avenue, Rhyl, LL18 4HS, North Wales.

GW0LAL @ GB7ABC

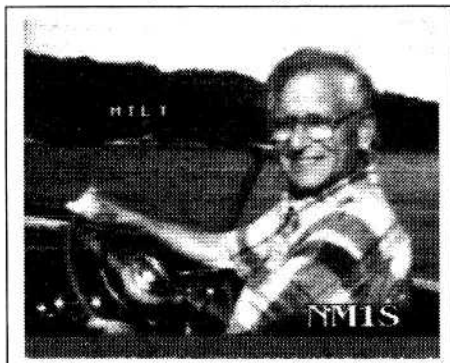

More on Modifying BSB Receivers

Trevor Brown G8CJS

In CQ-TV 159 we covered converting the Philips and Ferguson BSB receivers to D2MAC, so that they could be used after the switch-off of Marco Polo, to receive the French and German TDF and TV SAT satellites. Since then Trac, the company that provided the software for the Ferguson SRB1 receiver, have taken things a step further, by providing a replacement board service that adds both PAL, and D2MAC to the SRB1 receiver. They were kind enough to lend CQ-TV one for review, but unfortunately, it arrived the day after CQ-TV 160 went to the printers.

The 'conversion' is simplicity itself. You send them the main PCB out of your receiver and they send you a replacement, with all the modifications fitted and tested. Replacing the main PCB can be done in less than five minutes and requires a medium 'Philips' or crosshead screwdriver. There is only one cable to disconnect (and reconnect) and that is a short ribbon cable supplying power to the PCB, even that has a plug and socket arrangement, so there is no need for a soldering iron!

Once the PCB has been replaced and the lid refitted, it is ready to use. When power is first applied, it goes into standby mode with the familiar (to existing users of this receiver!) '--' displayed on the LED display.

THE MANUAL

The conversion comes with a manual, consisting of eleven sheets of A4 paper stapled together. The first page consisted of 'features' and 'contents', the second a set of specifications. The manual then went on to give a brief description of how best to connect the receiver to your TV set, followed by the operation of the receiver using the remote control. I only found two mistakes in the text, one a spelling mistake, the other a more obvious wrong word, but if you read it twice, it is obvious what is really meant (See if you can spot it!).

The last part of the manual gives details of how to modify your squarial or compact dish LNB for different polarities and a list of pre-set channels for various satellites. This is a great help when first setting up, as you can select a channel and be reasonably confident that all you need to do is point the dish the right way to get a picture! Incidentally, all of the sixty pre-set channels can be retuned to different frequencies in case you don't like the way Trac set it up. The last page of the manual is a pictorial representation of the menu structure, which is a great help in getting to grips with it.

THE MENU SYSTEM

The different channels are all set up via the menu system. At first it was a little confusing, but then I read the manual and it became a bit clearer! The manual does describe how to set everything up quite well and I found no obvious discrepancies in the text. There were a few minor difficulties, particularly with the language selection. This seemed a little erratic in the choice of languages displayed and which one it defaulted to, it also seemed to jump to different sound channels even after I selected one and 'stored' it from the main menu. I got the feeling this was more to do with what the broadcaster was transmitting than a bug in the software, but perhaps the software is trying a little too hard to supply all the available options?

PERFORMANCE

So much for the operation of the receiver, how about its performance?

Well, on the whole it performed very well. In D-MAC and D2-MAC mode the picture and audio quality was excellent, this was using the RGB output. The composite output was (understandably) not as good as the RF output. The Ferguson receiver is well known for its variability in the quality of the composite output and there are various mods floating around to improve it. I did not see any evidence of these mods on the PCB supplied, but then again the composite output was not as bad as some I've seen, so maybe I just got a good one. Most noticeable was the difference in contrast when switching between RGB and composite, the composite signal had a much higher contrast.

In PAL mode things were not quite as good. Obviously there is no RGB output when in PAL mode, so you have to rely on the composite or RF outputs. The first thing you notice is that the picture vanishes whenever you use the menu system, this is because the character generator is genlocked to the incoming signal by the D/D2-MAC chipset and if the incoming signal isn't D/D2-MAC then it won't genlock! Fair enough though, the manual does warn you about this and the software compensates for this by allowing an 'extended' tuning mode for PAL. The idea is that when in D/D2-MAC mode, you can see part of the picture around the edges of the menu. This is a great help when trying to tune in to a station. In PAL mode obviously this is not possible, so the extended tuning mode turns off the menu and shows you the incoming signal, whilst still allowing you to tune the receiver. When you have the best possible picture, you can turn on the menu again and store the settings, a very thoughtful addition.

I did try the receiver on one or two satellites and the results were very encouraging and every bit as good as my Echostar SR1000. Video was excellent even on RAI Uno, one of the weaker feeds on Eutelsat, with just a trace of streaking on fast edges (captions, etc.) and slight sparkles on saturated colours. On the stronger channels colours appeared clean and with no trace of sparkles, even though the bandwidth is

quoted as 30 MHz (Eutelsat uses 36 MHz channel bandwidth). RAI Uno's audio was just a bit too high in deviation for the SRB1 to cope with cleanly, but results were acceptable for most of the programming. As I suspect the SRB1 is intended mainly as an Astra receiver then this will not be a problem. I also had a look at signals from the French Telecom series of satellites. Telecom 2A and 2B now carry the old channels from Telecom 1C. The Secam pictures were resolved well using a modified TX9. The audio tuning made it down to the 5.8 MHz audio carriers with no problems. Finally I had a look at Astra and the results were again excellent, the pretuned channels were spot on.

The only problem in picture quality I found in PAL mode, was crosstalk from the D/D2-MAC output. Whilst it seemed that the RGB signals are turned off when in PAL mode, the output from the PAL coder (used to generate composite video in D/D2-MAC mode) is still present generating a black & burst signal. This gets superimposed on the received PAL signal. It's of a fairly low level and may be due to insufficient isolation in the switching circuitry, but under certain picture conditions (large grey areas mainly) it can be seen floating through. It is very noticeable when in the extended tuning mode, as the RGB outputs are not switched off and the menu can be seen quite clearly floating through! Perhaps if screened cable had been used for the signal connections..... ? I have sent a copy of this review to Trac as the review model was one of the first to leave the factory and I hope that this will be corrected on later models.

CONCLUSION

Overall I liked it. It has a lot going for it, especially the price of £69. The software is extensive and I liked the menu driven system, it is fairly 'user friendly' and once you get used to it, quite easy to use. I felt it could have been laid out a bit better, but that's probably just personal preference and I'm trying to be objective!

The response time between pressing the button and something happening on the screen was a little too long for my liking and I found that when tuning video (or audio in PAL mode) it tended to overshoot.

It's a pity the audio is only mono when in PAL mode. It might have been better to have gone for a fixed stereo system rather than a tuneable mono one (or both!). The audio quality in PAL mode was adequate and compared favourably with medium quality Astra systems (£400 - medium quality system).

Picture quality was a bit poorer than my existing system in PAL mode, but it was still quite watchable. The main problem here was the crosstalk mentioned earlier.

One thing to watch out for is the 'external switch'. This is intended to act as a trigger signal for an external device, such as an antenna changeover. The manual states that in its on state, it supplies +12 volts and when off, 0 volts. Thing is, it uses the RS232

output and when off actually sends out -12 volts, not 0 volts! The manual should have mentioned this, just in case anyone connects some highly expensive piece of equipment to it and damages it!

Finally, the external decoder option. I haven't got an external Videocrypt decoder, so couldn't test it properly. I did however link it across just to make sure it worked - and it did!

So if you've just bought a Ferguson SRB1 cheap, or you're wondering what to do with your existing receiver after Christmas, and you've got £69.00 to spare, I can recommend the Trac conversion. By the way, if you just want to have a look at D2-MAC and you're not interested in the PAL option (perhaps because you've already got a PAL system) then Trac are also selling a D2-MAC only, conversion for £19.95. I gather this hasn't got all the fancy menus, but will reliably decode D2-MAC for you.

THE 'SATELLITE SURPLUS' KIT

Another PAL conversion kit from Satellite Surplus also landed on my desk. Again this Kit is designed to provide a PAL compatible output from the Ferguson SRB1 BSB receiver. It comes with a manual, consisting of five A4 sheets stapled together. The kit is in two parts, an FM sound demodulator kit (originally from Cirkit !), and a piece of Veroboard (Yes, Veroboard !) and the components. The manual explains how to construct the video clamp circuit on the Veroboard, and the Cirkit kit details how to construct the FM sound demodulator. Total build time around 1/2 to 1 hour. Connecting the two boards to the SRB1 is pretty simple and full details are provided, if you decide to include all the switches the kit provides total construction time should be around 2 hours.

RESULTS

The quality of audio and video provided leaves a lot to be desired! The video circuit consists of a simple diode clamp, this is not really 'man enough' to get rid of all the energy dispersal signal from the video, resulting in a slightly jittery picture. The audio had an annoying buzz present (not too loud, but definitely audible), probably due to inadequate filtering (a single L/C combination) from the video.

The kit did NOT come with the required EPROM to allow you to tune the SRB1 and simply assumes you have already 'acquired' this. As the kit costs £20.00 and a suitable conversion EPROM will cost you around £20.00 the economics of going this route seem a little out as the kit version of the replacement board conversion from Trac is now available and costs just under £50.00)

CONCLUSION

Unfortunately not the best PAL conversion I've seen for the SRB1, a much better video clamp could be designed by any technically minded ATV enthusiast (just look back through previous editions of CQ-TV) and the audio FM demodulator can be bought directly from Cirkit for £6.58. However, anyone interested can contact Satellite Surplus on 0952 598173.

THE 'CHRIS SMITH' SOFTWARE

Chris Smith of I2C fame has also entered the D2mac software market with a conversion EPROM again for the Ferguson SRB1, it provides you with the ability to decode D-MAC and D2-MAC signals, also with some extra hardware PAL and teletext as well! The software is all menu driven and provides 60 fully programmable channels. It can also decode radio channels on D/D2-MAC signals. Also included, for the technically minded, are facilities for monitoring data packets included within the D/D2-MAC signal. All working parameters for the receiver can be altered and stored in non-volatile memory, such as Brightness, Colour, Contrast, Volume, etc. When tuned to a D/D2-MAC signal, it can display information about the signal, such as orbital position of the satellite, polarisation, country of origin, channel name, etc. Priced at a very modest £15.00, you can obtain further details from Chris Smith on (0933) 58220.

DO IT YOURSELF 'TREVOR BROWN STYLE'!

Having told you how to get PAL on the Ferguson BSB receiver by spending money with commercial companies, I thought we really owed you something you could do for yourself for very little cost. The Philips receiver is also capable of receiving PAL and Fig.1 shows a simple hardware add on that can be put together in a single evening and provides a PAL video output.

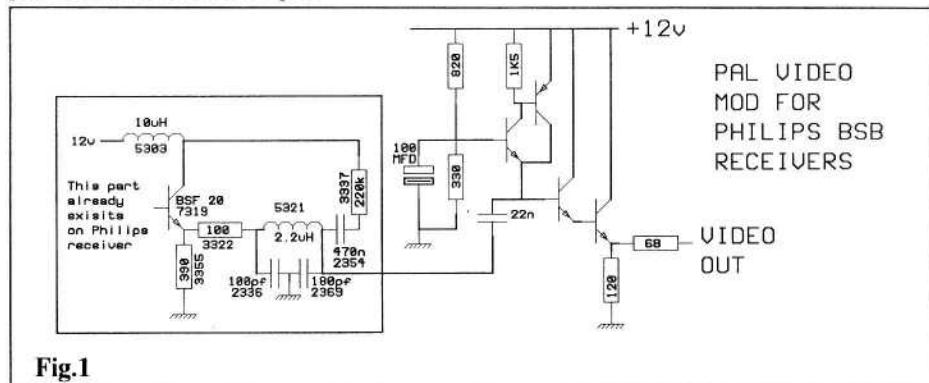

Fig.1

The circuit in the box is part of the Philips receiver and is reproduced here to help you locate the necessary components. The part numbers indicated in the diagram are printed on the PCB. The only component you need to locate is the 2.2uH inductor 5321, which is located on the main PCB under the bottom left corner of the ACM. The connection is made to the end furthest away from the tuner unit. Ground is available on the modulator can, and is also a good place to mount the additional video circuitry, which can be assembled on a small piece of Veroboard. The +12 can be picked up on link 9605, which is again clearly marked on the PCB.

The components used were not critical, almost any PNP and NPN transistors can be used. The circuit works by taking a feed of the baseband signal, unfortunately after DMAC deemphasis. Black level clamping is used to remove the energy dispersal. The signal is then buffered so as to produce a 75 ohm video signal suitable for driving a monitor, or the Scart, or video input of a TV set. The results were good despite the incorrect deemphasis, I suspect the ACC in the monitor took care of these problems. The Philips AFC is a little sloppy when used for PAL and does cause sparkles to come and go at dispersal frequency on weaker signals. I suspect for 24cm ATV work this would not be a problem. I have yet to see amateurs use energy dispersal.

It goes without saying that this hardware mod is of little use unless you fit the D2MAC software, which enables the receiver to tune the band from 11727 to 12144 in 4.8 MHz steps, using the original BSB LNB. An Astra LNB can be fitted, and this will enable you to tune the bottom 400 MHz of the Astra satellite.

If you fit a Marconi LNB, then switching between horizontal and vertical polarisation is achieved by imposing different DC voltages on the coaxial CABLE. Fig.2 shows how to add this capability to the Philips receiver, by putting a 9 volt zener diode in series with the existing diode 6401 (BDY33J), which is located at the back left corner of the main PCB. The zener needs to be A 1 watt TYPE, and will then function without a heat sync. S1 will now switch the LNB supply between 11 and 18 volts and thus switch the polarisation.

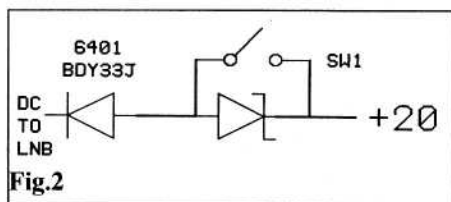

The reference to PAL on both the Ferguson and Philips receivers of course means SECAM and PAL for those of you equipped with a monitor for both systems, or those of you prepared to watch black and white pictures. The Telecom satellites at 5 degrees west can yield some interesting results. The Band they operate in is above 12144, but can be reached by retuning the BSB LNB's. The Polarplexer needs setting to linear and the LNB DRO needs tweaking about two to three turns clockwise. This is accessible via a hole in the LNB case which is located below the Polarplexer. The hole is plugged by some black sealant which can easily be removed.

The signal strength of the Telecom satellites is comparable with Astra, so some good

sparkle free results are possible even with a 60cm dish. The set up I used was the Ferguson receiver which tunes 400 MHz further up the band. I have not tried tweaking the BSB LNB's down further to bring Telecom within reach of the Philips receiver.

Since I started the original article on the DMAC system and the subsequent article on adaptation of DMAC BSB receivers to D2mac and then PAL, I have received a lot of correspondence and a lot of help from various people in the form of circuits and help in testing and reviewing equipment. I cant thank you all in this small space but I would like to thank Richard Russell, Chris Smith, Richard Edson, Phil Goldsborough, Paul Pitts, Bill Edwards, Paul Haworth and Brian Alderson.

HOME COUNTIES TV GROUP

John Bales

STRIKES AGAIN !!

Publicity Officer HCTVG

As many of you will be aware the Scout movement holds a Jamboree On The Air weekend in October each year, the object being to contact and exchange greetings messages with other Scouts and Guides across the world by radio. The 1992 theme was 'Great Towers', with Blackpool Tower and the BT Telecom Tower (London not Birmingham that is) being chosen as sights in the UK. The Home Counties ATV Group was approached by Paul Bateman, National Scout Adviser, to see if we could



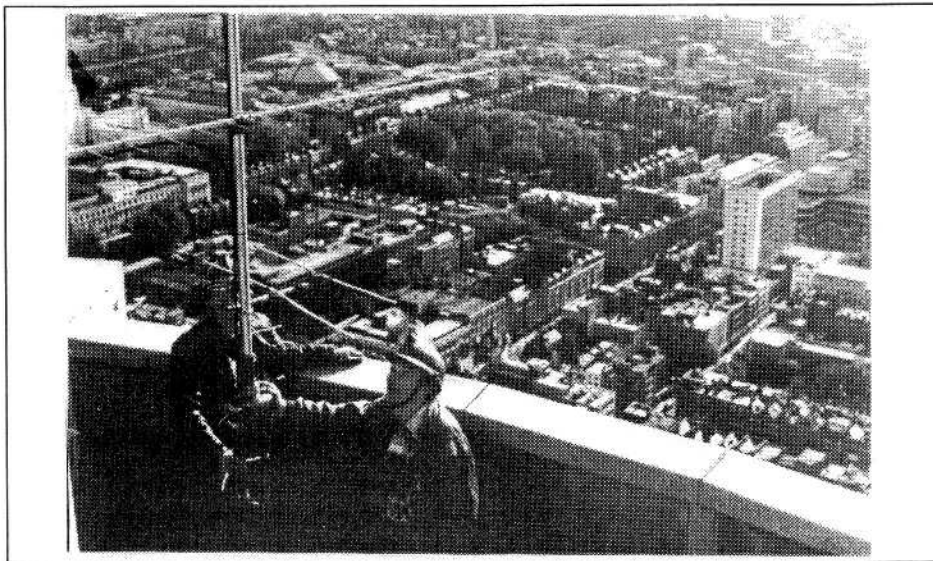

provide ATV in addition to the several HF stations to be sighted at the telecom tower. An opportunity to run an ATV station in the centre of London with aerials sighted 550 feet AGL was one not to be missed! Despite the relatively short notice for the project and rigorous security at the Tower, not to mention 125 foot runs of LDF 450 from level 34 at the restaurant floor to level 37, the aerial platform level, John G0HAT and Lewis G6HVQ were QRV on both 70 and 24cm for the two days, assisted by Dave G0FVT and Rod G7MEV under the callsign of GB2BT.

Parties of Scouts and Guides arrived at Telecom Tower each half-hour and a full-duplex colour link with GB2OST under canvas at Waldingham, Surrey, manned by John G8MNY and Andy G4WZG provided a lot of interest with the opportunity for exchange of greetings messages in sound and vision. We were also able to link with GB2WES Scouts in Southampton in vision crossband 23cm/70cm via Mike G8LES at Four marks in Hampshire, with sound on 2m.

The use of three colour cameras and a vision switcher enabled us to provide a good selection of shots of the visitors and the London landmarks. A camcorder was used to cover the areas beyond the reach of cable-bound cameras, including the express trip in the Telecom lift from ground level to the 34th floor in just 30 seconds! When time allowed we took pictures from the Kent and Dunstable Downs repeaters - both P5 using a single 23-element Tonna looking through the windows at level 34. Unfortunately, it was only possible to sight the main aerials to look from east to west via south.

Our special thanks go to Kim Fitzimmons of BT's PR Department, rigger Alan Howard and the BT staff who kept us so well supplied with refreshments throughout the two days of operation.

TV On The Air

Andy Emmerson G8PTH

Greetings at the start of a new year and here we are back on schedule with the activity round-up of the past quarter.

First letter out of the file comes from Les Huntley G4LW in Trowbridge, Wilts.. He writes: "I have just joined the BATC again after being absent since the early 1970s. I have nothing on air yet but will make a start with 70cm monochrome transmissions and maybe later 23cm colour." He continues that he was active back on the 1960s when he and the late Cyril Chivers used to send 405-line picture across town. He was first licensed in 1939, so that's not bad going.

Another person who's been involved in ATV for more years than many is Gordon G3LEE. He gets a name check in 'Der TV-Amateur', the German ATV club's magazine. Yes, it's twenty-five years ago that Mancunians G6LEE/T and G6ACW/T (note the old-style /T callsigns for television operation - you needed a separate licence then) made the first amateur PAL colour transmission in Europe. The date was 18th April 1968, beating the Germans: DL2OU in Bergkamen sent PAL signals to DC6MR in Dortmund two months later on 16th June.

Gordon writes: "Fancy the German magazine remembering the first PAL transmission! It was between me and Tony Jacques G3PTD. I borrowed the early Philips colour bar generator from you-know-where (well, yes, I do) and Tony transmitted to me. I had the giant ex-GEC EDT5 colour receiver which I had modified from British NTSC. Now there's a blast from the past: British NTSC was on 405 lines with a 2.77 MHz subcarrier."

And another letter from Manchester, from S. Shannon G0NCJ. "I read with interest the ATV columns written by yourself in Backscatter in Practical Wireless whenever I get a chance to do so and the pressures of work permit. During the past few years I have become increasingly interested in the world of ATV from listening to the talk-back frequency used by a group of ATVerS in the Manchester area. The said group send each other pictures (fast scan) somewhere in the 1296 MHz band and there is also some activity in the 70cm band.

"I have recently acquired an old Microwave Modules receive converter to enable me to view TV activity on 70cm but I am currently building a beam antenna for this band so have not as yet been able to receive any pictures.

"Anyway, to the point of this letter. It has been brought to my attention that it is possible to receive pictures on the 1296 MHz band via an average satellite TV receiver as many of these tune this frequency without modification. I am the owner of

such a receiver (Amstrad SRD400) and would very much like to use this to tune the 1296 MHz TV allocations. Could you possibly advise me as to whether this information I have been given is correct and whether it is possible for the Amstrad units to cover this frequency? I would very much appreciate it if you could advise me as I don't possess a specification manual for this piece of equipment.

“An idea for a future article in ATV Backscatter would be information on exactly what equipment is necessary to enable one to get going in ATV, also where to purchase equipment from as over the couple of years, or so I have taken an interest I can honestly say that I have never seen any advertisement in PW (or any other amateur radio publications) of stockists of this kind of gear. I really think an article of this kind would be appreciated by all would-be and existing TV enthusiasts alike and would am sure help promote more interest and use of ATV.”

This kind of letter is a little disappointing because I wrote two articles on exactly the subject Mr Shannon is asking about, namely a beginner's guide to starting ATV. It was published in PW's companion paper “Short Wave Magazine” in two issues last summer, and I too was sure it would help all would-be and existing enthusiasts! Oh well... As for the query about using satellite receivers from 24cm ATV reception, I can confirm that G0NCJ's Amstrad is an average satellite receiver and it is therefore suitable - as long as you use plenty of preamplification. Ideally you need a mast-head preamp and another one in the shack; this is because the satellite receiver is expecting a strong signal 27 MHz wide and a weaker and less widely deviated ATV signal is not going to make much impression unaided.

The letter illustrates another point too. I get quite a few which ask for a personal reply but with no stamped addressed envelope enclosed. Those letters do get answered, but only in the column, and enquirers seeking more personal attention to their letters might consider enclosing a SAE (and writing on the back of a £5 note if the matter is urgent!). Only joking about the £5 note...

Did you remember to watch out for the ATV activities in connection with the Scouts JOTA (Jamboree on the Air)? John Norris G4JEN in west London did and writes: “You may find the enclosed very grainy pictures of use in one of your ATV features. They were received on Saturday 17th October on a de Graaf D51 TV fed from a ten-element Group A Yagi 20 metres above ground level pointing at Crystal Palace (which is 16 km SE of my location). The aerial is definitely not rotatable as it feeds a CATV system to 15 other households.

The pictures are from the JOTA station GB2OST (Oxted Scout Troop) 20 km SSE of me. They were running 40 kW e.r.p. from a site 245 metres above sea level located just inside the M25 on the Surrey/Kent border.

I'm sorry there are no pictures from GB2BT from the London Telecom Tower. Being only 3.3 km due east of me they were P4 off the side of my 'beam', but after getting over the surprise of finding them on 'channel 5' (programmed with 435 MHz) and by



Oxted (Surrey) Scouts ATV station GB2OST received in west London on 17.10.92 by G4JEN.

the time I had gathered my plugs and leads to record to video they had migrated to 23/24 cm.(which I cannot receive, yet!) Hope this may be of use.”

Yes, thanks John. All photos are of use and welcomed with open arms. So are letters and here's one from Jos, ON7TP in Liège, Belgium. “Here in Belgium there is still ATV activity but do not forget we have Flemish and Walloon people! A difference in the language is like a barrier. The club ATVB is still alive and our yearly assembly was on October 3 in Heist op den Berg (always the first Saturday of that month). I'll try to write a small report. (I learned English while staying in Germany - it is the truth!)”

Our last letter this time is from Mike Sheffield ZL1ABS in New Zealand; here's what he has to say. “The recent level of activity in Auckland has been very welcome. Five stations in the same weekend working through the ATV repeater qualifies as a ‘pile-up’ compared to one or two in the winter season past. There are more transmitting stations under construction by Rod ZL1VLZ, Scott ZL1UWQ and newly-licensed Ashley ZL1VOX (neat callsign he got, eh?). The monthly ATV interest group meetings are continuing to be well attended. They are usually on the last Sunday of the month and are very valuable for exchanging ideas, showing off your latest homebrew item, swapping video tapes, getting technical help with equipment and just having a good face-to-face chat.

“A construction team of Michael ZL1ABS, Bruce ZL1BLB, Ian ZL1TOQ and Rod ZL1VLZ are building some ‘bells and whistles’ for the ZL1BQ ATV repeater in

Auckland. Michael is building a stepping tones audio generator and modifying a digital speaking clock for repeater use. Bruce is building a two-way electronic A-V switch and a video sync detector to operate it from the repeater's receiver. Ian is building a new channel 39 (615.25 MHz) transmitter and driver stage. Rod is building a black and white SSTV receiver for the repeater. Further items will be made when there is someone with time to build them.

"The repeater already has a four-page teletext-style beacon, DTMF receiver, colour bars and two other test cards. Input is 70cm (443.25 MHz) and output is 50cm (channel 39 or 615.25 MHz). FM sound subcarrier frequencies are +5.5 MHz. The beacon text runs 24 hours a day and there is a regular ATV net on the repeater on Sunday evenings, starting at 8.45pm. The two metres liaison frequency is 147.400 MHz simplex.

"This weekend, the 21st November, I'm off for a ten-day holiday. I have booked a cottage in Palmerston North (midway down the North Island). The local club is having what you would call a rally on the 22nd at a town called Woodville - they're calling the event the 'Woodville Eyeball'. I aim to be there. The small ATV group in Palmerston North are building a repeater, and I hope to see how its going and offer assistance. Later in the week Wayne ZL1UJK will join me on a day trip to Wellington and the monthly meeting of the Wellington VHF Group. I hope to visit some ATVers in Wellington and see the newly fitted PM5544 test card operating in the ZL2WA ATV repeater there. It has the same 70cm/50cm input/output as used in Auckland.

That's it for this time; how about seeing your callsign mentioned next time? Start writing now! Andy Emmerson G8PTH, 71 Falcutt Way, Northampton, NN2 8PH.

Linie D

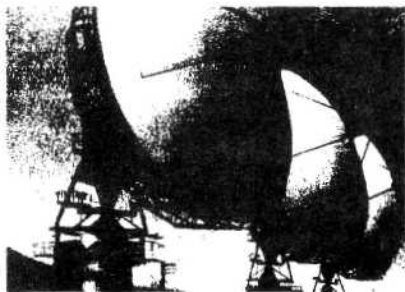

Components for satellite DX

Components of Linie D are tools for picture improvement for satellite DX and weak signal reception.

Interested?

For full details please write or phone. We will send you our free documentation.

NKM - Elektronik GmbH • P.O. Box 1705 • D-7850 Loerrach
Tel. +49 7621 / 18571 • Fax +49 7621 / 18840



HOW TO CONSTRUCT INDUCTORS

John Cronk GW3MEO

Small inductors for use in video networks are available ready-made, but I often find it convenient to make my own. The following notes are offered to like-minded practitioners.

The winding table using ferrite beads is only intended as a guide, the inductance values have been rounded to the nearest μH . Winding the wire tightly can increase the inductance by 5 to 10%. The only obvious difference between the type A and type B beads is that the hole is slightly smaller on the type B, although probably the type of ferrite is also different. For this reason, it is advisable to check the inductance. The inductance increases rapidly with more turns, due to mutual coupling. The effect of increasing the wire gauge is not clear.

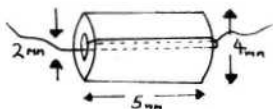

RS238-283 Anti-parasitic bead.
Type A. RS. Components.

0.2mm Wire		0.315mm Wire	
TURNS	μH	TURNS	μH
3	9	3	15
4	16	4	25
5	26	5	35
6	35	6	49
7	44	7	55
8	60	8	80
11	100		
15	150		

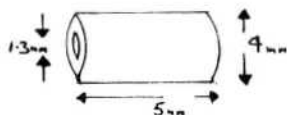

Bead with smaller hole
Type B. origin unknown.

0.2mm Wire	
TURNS	μH
4	6
5	9
6	13
7	15
8	17
9	22
10	30
11	35

I recommend the resonance method of measuring inductance in preference to the bridge or reactance method because:

- ☞ a) the test frequency appropriate to the application can be chosen;
- ☞ b) resistance does not cause errors;
- ☞ c) frequency can be measured accurately;

- ☞ d) self-capacity can be swamped by choosing a suitable value for C;
- ☞ e) resonance is shown very positively on an oscilloscope by the change of phase as the resonant frequency is tuned through.

When the value of C and F is known, then L can be calculated, or the resonance charts in the radio handbooks can be used, but with less precision. For the examples shown, the generator was required to tune between 0.4 and 1.5 MHz, with C having a value of 2000pF.

Recently, three inductors, 2.88, 1.54 and 1.72 μ H were required for a CCIR 5 MHz low-pass-filter. Using small formers with adjustable cores they were completed in an hour. It was most satisfying to find that the filter worked perfectly, when a plot was drawn using a signal generator and voltmeter manually.

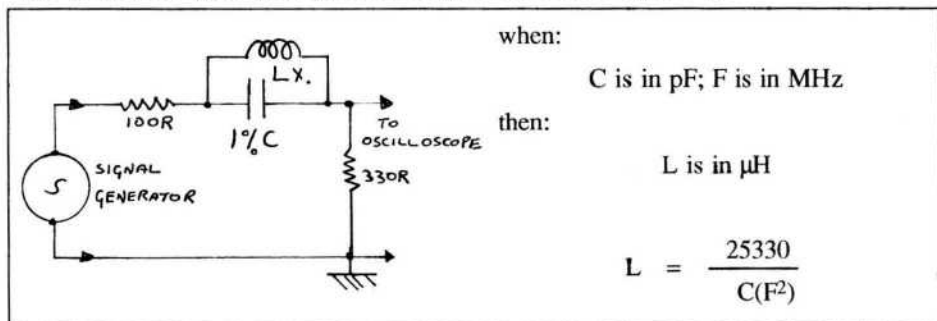

TH2SAT WEATHERSAT SYSTEM

Review

Mike Wooding G6IQM

Although many of you probably view Weather Satellite reception to be in the realms of our friends the Remote Imaging Group, I reckon that anything that ultimately deals with the reception of pictures also has a valid place here in the Club's magazine. Feel free to castigate me - some of you usually do! So be it! I shall continue.

The package I am reviewing here was sent to me by TH2 IMAGING after a discussion we had concerning their advertisement, which appears elsewhere in this issue. Having a personal interest in Weather satellite reception I decided to conduct this short review of their system to see what it has to offer - and I am impressed!

TH2SAT is the name of the package, and comprises a software suite for the ubiquitous PC and a PC card to fit into a spare slot (if you have one!). The software is self-installing and, after answering a simple on-screen prompt, is operational within

minutes of receipt. The card takes a little longer to fit, as you have to remove the cover from the PC! The card is a 'half' sized card and only requires an 8-bit slot. The system will receive and display images both in the visible and infra red spectrum from the METEOSAT, NOAA and METEOR range of weather satellites

The minimum configuration of the PC computer is your basic 286 machine (speed is not particularly important) with, preferably, a Super VGA display card and matching monitor. No expanded/extended memory is required, the basic 640k will suffice. A hard drive is imperative, with plenty of space if lots of images are to be saved and stored.

One very important feature of TH2SAT, which is not available in many other packages available, is that the image sampling rate is always 4800 Hz, so for METEOSAT reception (at 4 lines per second) the line sampling rate is 1200 Hz. The displayed resolution depending on the selected video mode (see below). When SVGA mode is selected (640 x 480 pixels) the received data is scaled to fit the picture. If video mode H is selected (1024 x 768 pixels, see below) every pixel is a separate sample resulting in a very high-definition displayed image. However, with some other packages this is not the case and the image is merely scaled to fit the screen, thus resulting in adjacent pixels having the same image data.

INSTALLATION

As previously stated the software package is self-installing, just answer the prompt requesting which drive to install it on and away it goes. Once installed the software prompts with the following message:

```
TH2SAT HARDWARE SETUP
Video Card   : VGA (Standard card)
Base Address : 300
Press ESC or ENTER (on keypad) to Exit
```

This now allows you to select the actual Video card to your requirements by using the left and right arrow keys. Video Cards currently supported by TH2SAT are:

VGA	TSENG ET-3000	TSENG ET-4000
TRIDENT	TRIDENT 8900	Paradise
Chips & Technology	Everex	Video 7
ATI Wonder	Oak Technology	Genoa GVGA.

This list extensively covers the most popular of the up-market SVGA display cards and also the standard types by selecting VGA. The machine I used for the review runs

a TRIDENT 8900 SVGA card, so I was able to run the system in all resolution modes to get the best impression of the results.

Once the video adaptor has been selected and the screen prompts followed the system then prompts for the required resolution mode. This prompt appears every time that TH2SAT is run. The three modes are:

- [V] 300 x 200 - VGA
- [S] 640 x 480 - Standard SVGA
- [H] 1024 x 760 - High Resolution SVGA

All three, or only one or two, of the modes are available dependant on the capabilities of the video card fitted to the computer.

THE MENUS

Having selected the required resolution mode the main menu appears which offers the following options:

- ☞ [R] Receive Image
- ☞ [L] Load Image
- ☞ [S] Save Image
- ☞ [Q] Quick Save Image
- ☞ [Z] Zoom Image
- ☞ [I] Image Information
- ☞ [M] Satellite Mode
- ☞ [P] Picture Show
- ☞ [V] View
- ☞ [ESC] Exit

There are three other menus, which are accessed by pressing F2, F3 and F4. F1 is used to return to the main menu from any of the other three.

F2 selects the Image Processing Menu, F3 selects the Palette Menu and F4 selects the Unattended Operation Menu. Some of the operations selected from within these menus also have sub-menus with further selection options. (I hope you are following me - I may be asking questions later!). The + and - keys vary the brightness of the image and are available within most menu operation and on all images excepting Infra Red.

From the main menu saved images may be loaded from disc by pressing L, which then brings on screen a directory listing of all image files available in the selected resolution mode held in the TH2SAT directory on the disc. To load an image simply

scroll down the list to the required one and press enter. Once loaded the menu can be removed from the screen by pressing V. To bring the menu back on screen any key may be pressed apart from the following:

- F2 to F4: which will display the other menus;
- + and -: which will vary the brightness of the displayed image;
- M: which will select the monochrome palette;
- G, Y, B or R: which will select one of the visible light palettes;
- 1, 2 or 3: which will select one of the infra red palettes.

The S for save and Q for quick save options are for saving received images to disc. S prompts you for a file name before saving, whereas Q immediately saves the image with the previous file name.

Z is the zoom feature. Selecting this brings a 1/4 screen sized box over the image which can be positioned anywhere in the image by using the arrow keys. Once the required area is inside the box pressing the enter key causes TH2SAT to display that 1/4 screen full size. The first zoom is carried out without any obvious loss in resolution. Subsequent zooms obviously cause the picture to become 'blocky' as one would expect. There is only so much information available after all. I found that after the second zoom the picture became too mode 7'ish to be of any use from the images I was using as sources. There is apparently no reverse process, so to return to the original image it must be reloaded.

Pressing I from the main menu brings on screen a centre box containing the date the image was received and saved, the Satellite Mode and information on the video resolution mode.

Pressing M brings on screen a sub-menu, from which the satellite mode can be selected for METEOSAT, NOAA or METEOR reception of visible or infra red images. The P option from the main menu allows you to display on screen in automatic rotation either a selection or all of the image files on disc that can be displayed in the current video resolution mode.

The F2 menu allows the actual received/loaded image to be manipulated. There are several very clever techniques which allow you to flip the image through 180 degrees, equalise or stretch contrast levels, give a negative or 3D image (I was particularly impressed by that one) and select various filters.

The F3 menu is the Palette menu, from which various colour tones for the image can be chosen. Also, the infra red palettes are selected from here. Operations of the F5 to F8 keys within these menu selections allow the sea and land colour boundaries to be varied for best results.

The F4 menu is the Unattended Operation Menu. This menu gives the option to set the time; plan a series of timed image loads or plan a series of image reception saves. This means that your system can automatically save pictures from the selected satellite completely unattended.

CONCLUSIONS

I found TH2SAT to be a very friendly, simple to operate, extremely easy to get going, yet very powerful package. Apart from the necessity to reload images after certain options had been selected and carried out I found nothing that I did not like - I must point out here that it may well have been me and not the software that got me into these positions of having to reload!

I should also point out that I have only skipped over the surface of the extensive facilities within the package. Suffice it to say that at a purchase price of only £100 inc VAT plus £5 postage it must be one of the few bargains in PC based amateur radio today. The only requirement for a complete METEOSAT, NOAA, METEOR weather satellite reception system being a suitable VHF receiver and an aerial. This first can be obtained from various sources such as Maplin and the latter also from TH2 IMAGING.

TH2SAT can be obtained only from: TH2 IMAGING, 34 Princes Gardens, Margate, Kent, CT9 3AR. Tel: 0843 223831 / 596256.

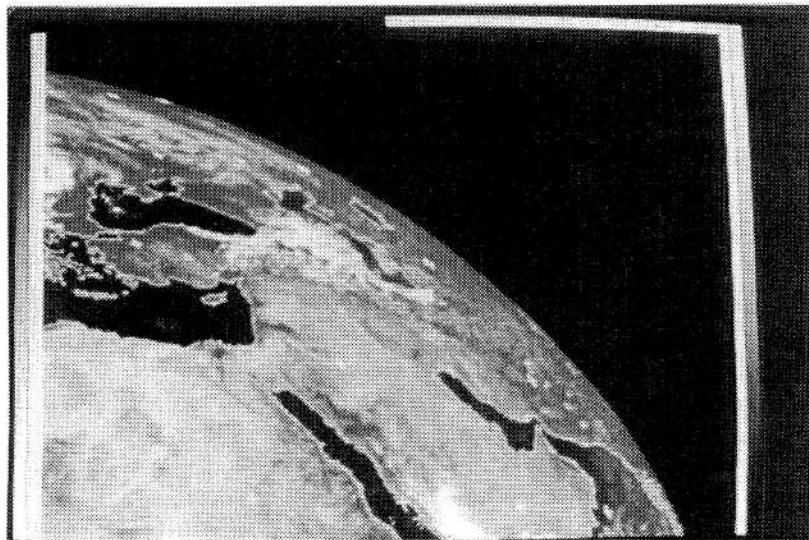

An off-screen photograph of a TH2SAT received METEOSAT Mode 1 Image received on 07/06/92 at 1213, showing a good view of the Nile Delta

Computer Assisted SSTV

Jamie Powers G0JNK

In light of the current debate on a new standard for slow scan I couldn't resist having my say. My starting point is the reason for the development of the slow scan mode. This, I believe, was to produce pictures of useable quality but maintain the immediacy of television all within the bandwidth of a phone contact.

The advances in slow scan technology to date have concentrated on improving the picture quality but as a consequence have increased the time for each frame. I feel that with a full colour high resolution picture taking over a minute to send the mode is heading more towards a colour fax system rather than television. So how do we reduce the frame time without increasing the bandwidth. I came up with the idea of removing the background unchanging information from each frame.

Nowadays most slow scan is generated and received digitally using a frame store at each end of the contact. I thought that by introducing a second frame store at the transmitting end the frame which has just been sent can be retained. The frame about to be transmitted could then be compared with the previous one and only the lines which were different should be transmitted.

The comparison can be done purely by comparing the digital values for each pixel in the line. A certain amount of change will be present purely because of the digitising process. Therefore a only if the changes in a line exceed a preset threshold value would the line be sent to the receiving station.

With this the background information is not being sent at all so I would use a separate counter in the electronics to send say ten percent of the picture regardless of any movement. This guarantees that all the picture information is sent within ten consecutive frames.

The receiver then needs to know which lines are being sent so that it would then only overwrite those lines in its frame store. This can be achieved by sacrificing the first line of the frame. This line can be divided into a serial data stream with one pixel per picture line in the frame. A white pixel would indicate that a line is being sent and a black pixel would indicate that this line is the same as in the previous frame. The amount of time required for each frame is then related to the amount of movement in front of the camera.

A further development might be to divide the lines in half for the comparison. This would use four levels of grey in the control line pixels to indicate whether all of the line, the first half, the last half or none of the line is being up-dated.

This basic idea expanded somewhat with the recent suggestions of using a control data byte in the frame sync pulse and introducing a low resolution (64 X 64) 2 second mode. With these two advances the frame time can become a standard length and the resolution of the picture altered to account for the amount of movement in the picture. Rather like the video conferencing techniques being used commercially.

I see that this system would work as follows: The first frame is sent out in 2 second mode and stored. During the 2 seconds a second frame is stored and compared with the first. If they were the same but for say the centre third the next frame would switch the receiver into 4 second (128 x 64) mode. The first line of the next frame would indicate the lines which have changed then the lines information would follow. To complete the 2 second frame time a sixth of the background information can also be sent to refresh the rest of the picture. These background lines would have been indicated in the control line at the top of the frame.

Whilst the second frame is being sent the third frame should be read in and compared with the second. Assuming only a few lines had changed. The next frame would switch the receiver into high resolution mode send the changed lines and more background information.

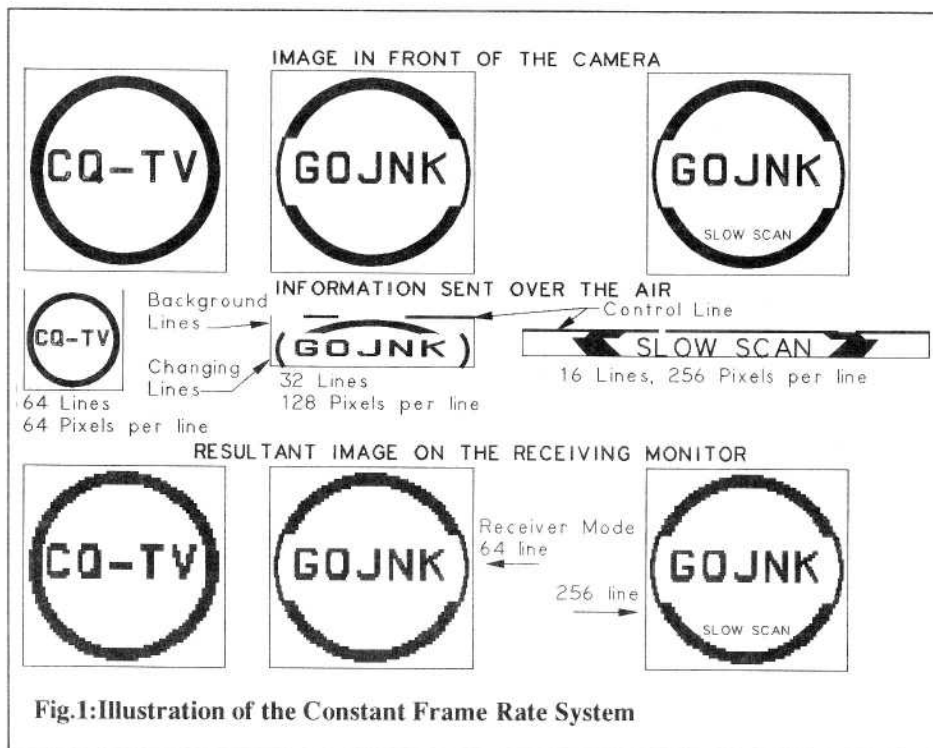

So if there is much movement then the system will be in low resolution mode with a 2 second frame rate but if you then point the camera at a still image the system will automatically switch into the highest resolution it can and send a full screen image over say 2 minutes.

To explain the principle I have assumed that an increase in resolution is the only improvement of picture quality. However, the system could switch from black and white to colour if the amount of movement in front of the camera permits.

The system, as it stands, gives us a video link with a 2 second frame rate within an audio a bandwidth of about 2.5 kHz. For the larger amateur bands such as 10m, 6m, 2m, 70cm and higher we could allow the luxury of using a 75 kHz band width. This would allow the frame rate to increase to 15 frames/second; near to continuous movement.

For a 75 kHz system I would remove the audio tones and directly modulate the RF carrier. I realise that the computing would also have to be done 30 times faster so this is probably an advance for the future.

Imagine how that would change the popularity of ATV if instantaneous moving or high resolution pictures could be sent long distances on 10m.

I would like to think that people with the computing skills could answer this suggestion as to whether it is achievable and then perhaps this could be considered as a new mode for video over the air.

NARROW BANDWIDTH TELEVISION ASSOCIATION

The Narrow Bandwidth TeleVision Association, founded in 1975, specialises in the mechanical and low definition aspects of ATV, and offers genuine (moving) TV within a basic bandwidth of 6 - 7 kHz. The techniques, basically an updated form of the Baird system, are a unique mixture of mechanics, electronics and optics. Membership is open World-wide on the basis of a modest yearly subscription (reduced for BATC members), which provides an annual exhibition and quarterly 12-page newsletter, together with other services.

For further details write to: **DOUG PITT, 1 BURNWOOD DRIVE, WOLLATON, NOTTINGHAM, N28 2DJ.** Telephone: 0602 282896.

Waveguide Transitions

Most LNB's use waveguide WG17, which makes connection and matching to WG16 difficult. I asked Mike Walters G3JVL if he had an easy solution to the problem of matching. Mike sent these details shown below, which I have redrawn for clarity and offer to CQ-TV with Mike's permission.

Anthony Horsfall G4CBW

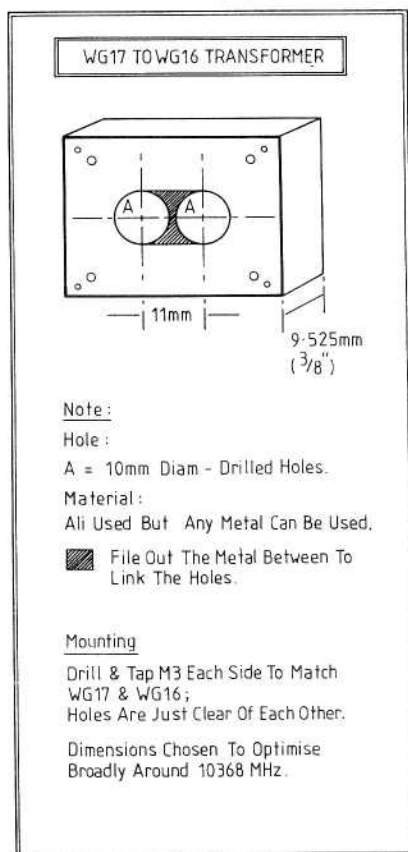
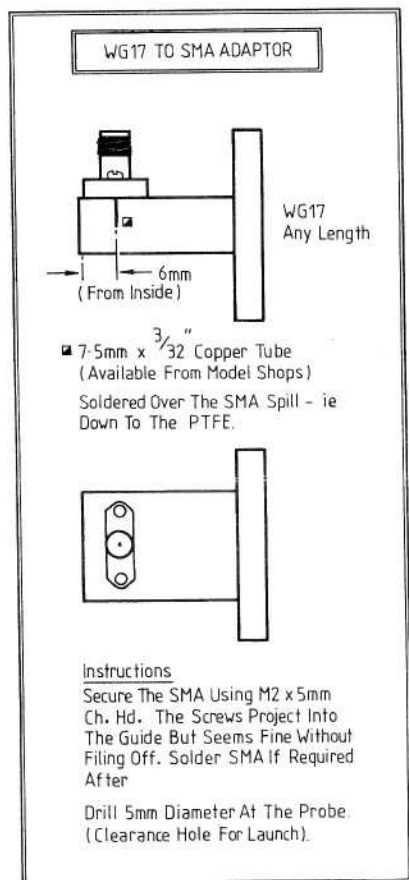

EASY-PC PCB and Circuit Diagram CAD

Forget using tapes and lightbox! Create your Circuit Boards using CAD - like the professionals.

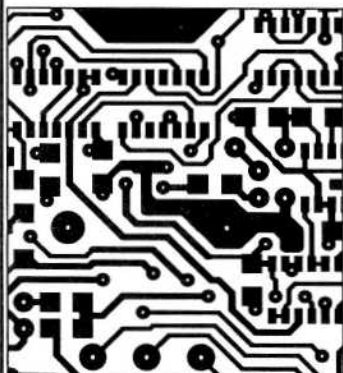

- Runs on PC/XT/AT etc. with Hercules, CGA, EGA or VGA display and many DOS emulations.
- Design Schematics Single and Double sided and Multilayer boards including Surface Mount.
- Standard output includes Dot Matrix / Laser / Inkjet Printer, Pen Plotter, Photo-plotter and N.C. Drill.
- Extremely powerful.
- Very easy to use.

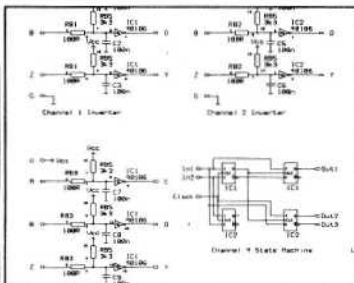

EASY-PC

Technical support is free, for life!

Only £98.00!

Plus P&P+VAT

Over 13,000 Installations in 70 Countries Worldwide!

Options:-500 piece Surface Mount Symbol Library £48, 1000 piece Symbol Library £38, Gerber Import facility £98.

DIGITAL SIMULATION £195

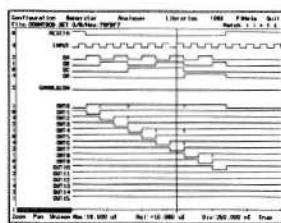

- At last! A full featured Digital Circuit Simulator for less than £1000!
- PULSAR allows you to test your designs without the need for expensive test equipment.
- Catch glitches down to a pico second per week!
- Includes 4000 Series CMOS and 74LS Libraries. 74HC/HCT libraries only £48.00 each.
- Runs on PC/XT/AT/286/386/486 with EGA or VGA.

ANALOGUE SIMULATION £195

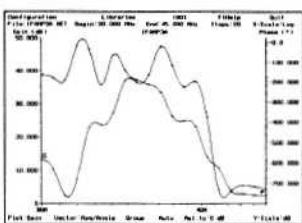

- NEW powerful ANALYSER III has full graphical output.
- Handles R's,L's,C's, Bipolar Transistors, FET's, OP-amp's, Tapped and Untapped Transformers, and Microstrip and Co-axial Transmission Lines.
- Plots Input / Output Impedance, Gain, Phase & Group Delay.
- Covers 0.001 Hz to > 10GHz
- For PC/XT/AT/286/386/486 with EGA or VGA.
- Very fast computation.

SMITH CHART CAD £195

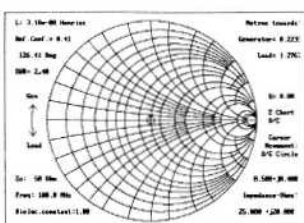

- Z-MATCH II simplifies RF matching and includes many more features than the standard Smith Chart.
- Handles transmission line transformers, stubs, discrete components, S Parameters etc.
- Supplied with many worked examples.
- Superbly easy to learn and use.
- Runs on IBM PC/XT/AT/386/486, CGA,EGA,VGA.
- Ideal for Education and Industry.

For full information, Write, Phone or Fax:-

Number One Systems Ltd. I

REF: CQTV, HARDING WAY, ST.IVES, HUNTINGDON, CAMBS, ENGLAND, PE17 4WR.

Telephone: 0480 61778 (7 lines) Fax: 0480 494042

International: +44 -480-61778, Fax: +44-480-494042 ACCESS, AMEX, MASTERCARD, VISA Welcome.

- TECHNICAL SUPPORT FREE FOR LIFE!
- PROGRAMS NOT COPY PROTECTED.
- SPECIAL PRICES FOR EDUCATION.



VHF **COMMUNICATIONS**

VHF COMMUNICATIONS magazine is published four times per year and is available from KM Publications, 5 Ware Orchard, Barby, Nr.Rugby, CV23 8UF, Warks. U.K. Tel: 0788 890365; Fax: 0788 891883. The yearly subscription is £12.00 for 1992 and £13.00 for 1993 - *both years for £22.50* - which is payable by credit card (+ a surcharge of 50p), personal cheque (drawn on a UK bank or bearing the name of a UK banking agent), postal orders or bankers draft made payable to **KM Publications**. This subscription includes surface mail charges, air mail is extra. The magazine is a **MUST** for the radio amateur interested in VHF, UHF and Microwave working, containing, as it does, detailed constructional articles for equipment operating in these bands.

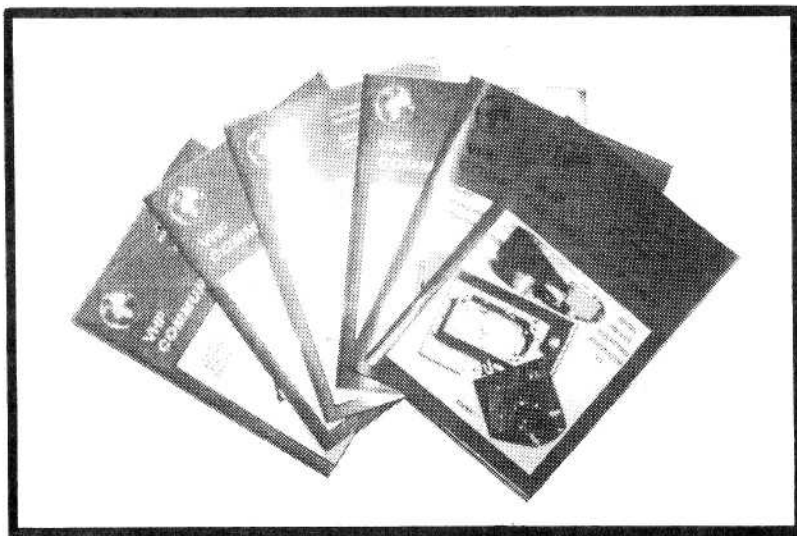

BACK ISSUES ... £3.50 each: £12.00 per YEAR VOLUME

BINDERS TO HOLD 12 ISSUES £5.00

Surface mail charges included - Air mail extra.

- TXV4000** 24cm Low cost Video transmitter, excellent miniature VFO design, 400mW output, 12V DC input, Ready assembled and cased transmitter.
- TXV4001** 24cm Two channel PLL video transmitter module, 400mW output, 26 MHz bandwidth. 12VDC input, complete built and tested surface mount assembly.
- PAI001** 24cm Power amplifier module to compliment TXV4000 series transmitters, 2.5Watt output, 12V DC input.
- LHA2001** 24cm Pseudomorphic HEMT ultra low noise GaAsFET preamp, outstanding performance using 0.15dB noise figure PHEMT ! Supplied in weatherproof IP65 enclosure with N connectors.
- CV7001** 24cm Down Converter, 40MHz IF output, 27dB Gain, 1dB Noise Figure. Complete built and tested surface mount assembly.
- MI9001** Phase Lock Loop module based on Plessey SP5060 IC. Complete synthesiser on single PCB, includes regulator and loop filter components.
- VIDEOIF** Camtech's complete video IF card demodulator, IF at 40MHz with 6MHz sound demodulator all on a single Euro card PCB.
- ASG+VOGAD** Intercarrier sound modulator board for TXV4000 series transmitters, enables you to transmit sound with your video pictures.

Specialist 24cm ATV suppliers, RF, Telecoms and Microwave design consultants + PCB CAD and prototype/small volume manufacturing service.

Severnside Television Group

A Guide to 23 cm Television

The complete beginners guide to setting up a 23cm ATV station.. Everything you need to know in simple terms. Written by the STG club secretary, Shaun O'Sullivan.

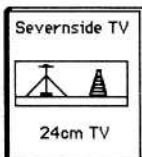

Price £3.00

+ 60p p&p

RGB to PAL Encoders

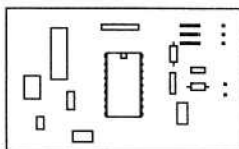

Our latest offering is ready built and aligned RGB encoder. It accepts 1Vpp ANALOGUE RGB and SYNC and gives 1Vpp composite PAL encoded video (75ohm). Suitable for converting a computer RGB output for transmission. Can be configured for TTL level RGB Based on the SONY CX1145 chip. All circuits and connection details supplied.

Price £32.00 inc p&p

Colour Test Card Generator

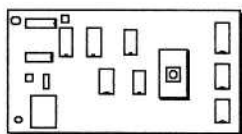

New!! The STG now offers a ready built and tested TEST CARD GENERATOR. Displaying up to 4 test cards ready programmed with your CALLSIGN and QTH. The cards cycle automatically or can be manually displayed. The output is 1 vpp PAL comp. COLOUR. Please supply your CALLSIGN and QTH with order.

Price £75.00 + £1.50 p&p

Severnside Television Group

15 Witney Close Saltford Bristol BS18 3DX
(0225 873098) after 7pm & weekends
Please allow 28 days for delivery



Aztex Electronics

24 cm Transmitters

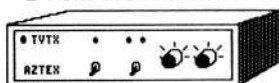

This state of the art FMTV transmitter gives a solid 2.5 W on either of the two switchable channels, 1249 & 1255 MHz. This ready assembled and tested unit accepts both line and mic inputs for intercarrier sound and front panel audio and video gain controls are provided. See CQTV 150 for review.

Price £265.00 + £6.00 p&p

24cm Power Amplifiers

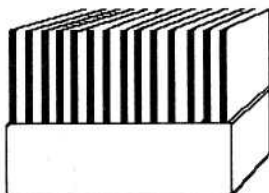

A 20 Watt PA using the SC1040 module is now available to accompany the AZTEX TX

Price £150.00 + £6.00 p&p

24 cm Pre-amplifiers

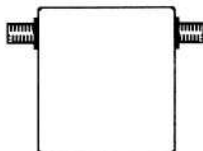

This GaAsFET pre-amp offers a gain of 17db with a noise figure of only 1db. Designed to go between the RX antenna and your receiver The gain is flat across the 23/24cm band but has an 8db roll-off at around 700MHz to help reduce broadcast TVI. A highly stable design based on the ATF10135 GaAsFET utilises SMT components and is boxed and aligned. NB the device does not contain RF switching.

Price £52.00 + £1.50 p&p

AZTEX Electronics

Ken Stevens G4BYK 20 Coberley Footshill Rd
Hanham Bristol BS15 2ES (0272 677005)
SAE for full details. Delivery is 28 days.

HS PUBLICATIONS
7 Epping Close
Derby DE3 4HR
England

0332 38 16 99

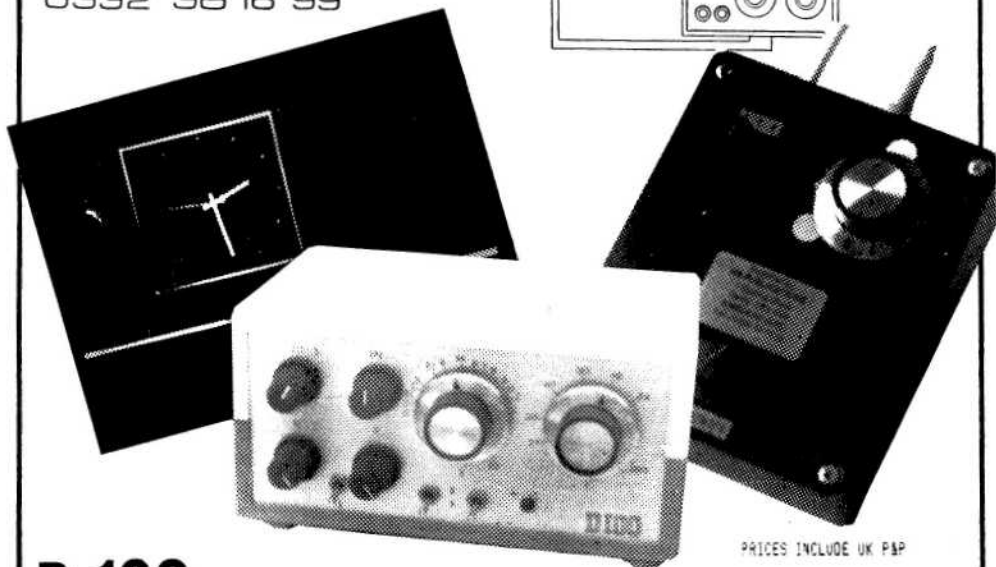
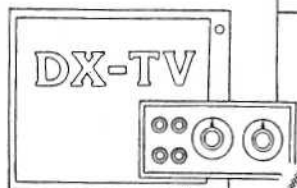

PRICES INCLUDE UK P&P

D-100 WITH BANDSCAN ONLY £99.99

STILL USING AN UPCONVERTER OR
TV WITH WIDEBAND I.F.s FOR DX-ING?

OUR RANGE OF CONVERTERS PROVIDES A NARROW IF BANDWIDTH FACILITY
ESSENTIAL FOR RECOVERING WEAK SIGNALS FROM THE NOISE.

THE LATEST D-100 FEATURES A USEFUL BANDSCAN FACILITY ALLOWING THE USER TO
PREVIEW THE BAND WHEN AN OPENING IS IMMINENT. IT'S IDEAL FOR WINTER DX-ING TOO
-LEAVE IT SCANNING VIA A SPARE SET WHILE YOU ARE WATCHING YOUR DOMESTIC TV!

HS D-400 SERIES ONLY £49.95

IMPROVE YOUR DX RECEPTION WITH THIS LOW-COST TUNER
(REVIEWED IN TELEVISION AUGUST 1992)

- * VARIABLE BANDWIDTH VISION I.F. (3-6MHz approx).
- * YOU CAN RECORD VHF DX RECEPTION FROM THIS UNIT
- * COVERS: BAND I NZ1-R4 BAND III E5-E12 UHF E21-50 APPROX
- * DC INPUT 13V - IDEAL FOR MOBILE USE
- * THE TUNER IS SIMPLE TO USE AND COMES COMPLETE WITH POWER UNIT

PLEASE ADD £8.00 TO THESE PRICES FOR AIRMAIL DESPATCH TO EUROPE

Sevenside Television Group Aerial Products

New!

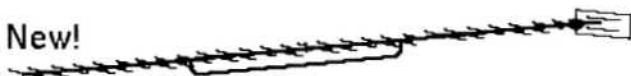

New!



New! A 38 element high performance version of our famous 23 cm aerial 14 db gain, SWR less than 1.5:1 and 1.8 metres long. Remember - all STG aerials are wideband to cover the repeater input and output. Launch price only £25.00 each, P&P £3.50 (1 item) £5.00 (2+ items)

New! No need to buy a new aerial, our 20 element extension upgrades your existing 18 element STG aerial to the full new 38 element specification. Everything you need is supplied. Launch price only £12.00 each, P&P £3.50 (1 item) £5.00 (2+ items)

The original 18 element wideband aerial is still available. 10 db gain SWR is less than 1.5:1, 90cm long and it covers the repeater input and output.

Still only £14.00 each, p&p £3.50 (1 or 2 items) £5.00 (3+ items)

New!

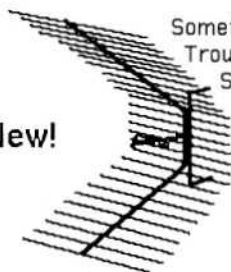

Something different for the mast! A 23 cm wideband Trough Reflector. 11 db Gain across the whole band SWR is less than 1.5:1 Overall dimensions: 55cm high, 35cm wide and 30cm deep. Supplied as a complete kit of pre-formed & pre-drilled parts for easy "screwdriver" assembly, no tuning is needed.

Launch price only £18.00 each, P&P £3.50 (1 item) or £5.00 (2+ items)

See our other advert for more products



We regret that we can only post aerials to UK addresses. Delivery 28 days. Cheques Payable to "Sevenside Television Group". Send to 15 Witney Close, Saltford Bristol BS18 3DX. Tel: 0225 873098 (after 7pm & weekends only please)

**THE WORTHING AND DISTRICT
VIDEO REPEATER GROUP
GB3VR ATV REPEATER BRIGHTON**

1W FM-TV 24cm TRANSMITTER THIS TRANSMITTER GENERATES ITS SIGNAL DIRECTLY AT THE WANTED FREQUENCY WHICH MAY BE SET ANYWHERE IN THE BAND. ON-BOARD INTERCARRIER SOUND AND FIXED PRE-EMPHASIS ARE STANDARD FEATURES. THE KIT INCLUDES THE DIECAST BOX AND COSTS £80.00

23/24cm ATV CONVERTER THIS UNIT BLOCK CONVERTS THE 1.3GHz TO THE DOMESTIC UHF TV BAND. USE THIS KIT WITH A STANDARD TV TUNER AND BATC IF PCB, FOR A COMPLETE FM RX SYSTEM. APPLICATION NOTES INCLUDED. £40.00 INC DI-CAST BOX.

TWO CHANNEL PLL THIS NEWLY DESIGNED TWO CHANNEL PHASE LOCKED LOOP WILL IMPROVE THE OVERALL STABILITY OF THE SOLENT 1WATT TRANSMITTER. TWO CRYSTAL LOCKED CHANNELS, AND A THIRD FREE RUNNING TUNING POSITION ARE AVAILABLE. KIT PRICE ONLY £30.00. CRYSTALS FOR THE PLL ON CHANNELS RMT1, 2, 3 OR SIMPLEX 125MHz £7.00 EACH. OTHER FREQUENCIES TO ORDER.

VIDEO AGC KIT. THIS UNIT ACCEPTS A COMPOSITE VIDEO SIGNAL IN THE RANGE 0.15 TO 2V p-p AND OUTPUTS A CONSTANT 1V p-p ACROSS 75-OHMS. THIS UNIQUE AMATEUR DESIGN IS A MUST FOR TV STATIONS AND REPEATERS. £16.00 EACH.

EXPANSION BOARDS FOR THE CIRKIT CROPREADY TEST CARD GENERATOR BOTH 2 AND 8-WAY EXPANSION BOARDS ARE AVAILABLE ENABLING THE SELECTION, BY S/POLE SWITCH OR BCD, OF EXTRA EPROM PATTERNS. PRICE: 2-WAY £7 & 8-WAY £18.

EPROM SERVICE FOR THE CIRKIT TEST CARD GENERATOR. A FAST RELIABLE SERVICE WITH A RANGE OF DESIGNS INCLUDING BATC, IBA LOOK-ALIKE, EBU TYPES 1 & 2 TEST CARDS, CONTEST NUMBERS, TEXT, GREY SCALE PLUS MANY MORE. THESE EPROMS ARE TO THE FULL SYSTEM I STANDARD. SAE FOR FURTHER DETAILS OR TEL. GEOFF ON (0903) 32161 (7 TO 8pm). PRICE: £6.50 PER CHIP. PLEASE STATE B/W OR COLOUR WHEN ORDERING.

COLOURISER KIT FOR THE CIRKIT TEST CARD GENERATOR. BY THE ADDITION OF THIS KIT, THIS POPULAR ELECTRONIC TEST CARD CAN BE UPGRADED TO PRODUCE COLOUR IN ANY GREY SCALE AREA, ON EXISTING OR NEW EPROMS. AN IMPROVED DESIGN TO THE CIRCUIT DESCRIBED IN CQ-TV 139. PRICE £20.00.

THE "NEW ATV" PROGRAM FOR THE 48K SPECTRUM. THIS VERSION HAS OVER 60 COMMANDS, WHICH INCLUDE 7 TESTCARDS, MEMOPAD, CLOCK WITH ALARM, MAPS, TONES, LOCATOR CALC (OLD & NEW), FLAG, X-HATCH, VARIOUS SIZE TEXT PRINTING PLUS A DISK TRANSFER COMMAND AND MUCH MUCH MORE. ALL THIS FOR ONLY £6.00. OPUS DISK VERSION £8.00. A MUST FOR ALL SPECTRUM OWNERS.

BBC AMATEUR TELEVISION PROGRAM FOR THE BBC MODEL 'B' AND MASTER. PROGRAM INCLUDES 8 TESTCARDS, MAIDENHEAD LOCATOR SYSTEM, VARIOUS MESSAGE PADS, PLUS MANY MORE FEATURES. AVAILABLE ON 80 TRACK DISC OR 40 TRACK D/SIDED DISC, FOR ONLY £8.50. SEND NAME LOCATOR AND CALLSIGN WHEN ORDERING.

ORDERS TO THE TREASURER OF GB3VR, :-

R. STEPHENS GB3XEU, 21 St. JAMES AVENUE, LANCING, WEST SUSSEX, BN15 0NN.



MARKET PLACE

ADVERTISING RATES:

Market place ads - £50.00

Full page - cover - £50.00

Full page - inside - £40.00

Smaller displays - proportional

*Advertisements are placed in this column free of charge to paid up members only, please quote your membership number. Addresses will be included unless otherwise requested. All paid advertisements are subject to standard rate VAT.

Copy should be sent to the Editor at 5 Ware Orchard, Barby, Nr.Rugby, CV23 8UF before 1st March. Tel: 0788 890365. Fax: 0788 891883.

FOR SALE

BSB SATELLITE SYSTEM, brand new Ferguson SRB1 receiver, remote control, boxed, squarial, on-screen menus, ideal for PAL or CAPGEN, etc., conversion ... £25 buyer collects. Sony Betacam single NP1A battery charger ... £60 ono. Piers Bedford. Tel: 081 747 0069.

BBC CAMERA TALKBACK HEADSETS, late 1950 style, set of 3 ... £5 each. AKG K.158 talkback headset ... £5. 96-way Bantam audio jackfields, 1 U rack mounts, set of 2 ... £12 each. Ops/Maintenance manuals for: BVU 800P VCR, DXC 6000P camera, BVT 800PS TBC, BVE 800 editor, Wex 2000P mixer/expander ... £10 each. Ops manual for: BVE 910 editor ... £15; VP2 char gen ... £10; DXC 6000P camera ... £2.50. Postage extra. Willing to swap for manual on Philips LDK5 or Rank Cintel Mk.3 TK machine. Nigel Phillips, 80 Johnston Road, Poole, Dorset, BH15 3HT. Tel: 0202 670733.

FOR SALE: SC77; this is a kit version of the Robot 400 SSTV TX/RX CONVERTER, sometimes called the Chinese copy, good working order ... £100. Hammalund SP600 COMMUNICATIONS RX, 0.54 to 54 MHz, miniature B79 valves, 1950's classic, with handbook, buyer collects ... £100. John Cronk GW3MEO, 2 Mostyn Avenue, Prestatyn, LL19 9NF. Tel: 0745 888355.

EVERYTHING MUST GO !: Camtech CV7001 24cm DOWN CONVERTER, 40 MHz IF ... £90. Camtech VIDEO IF video demodulator to suit ... £100. Camtech 23/24cm PREAMP board (built) ... £23. Wood & Douglas 1250FM1 23/24cm PA 20-150mW in 1W out ... £50. EME COAXIAL RELAY HF400 600W+ handling up to 13cm ... £65. EME VHF/UHF/SHF POWER METER, up to 13cm, 2kW maximum, complete with probe directional coupler, etc., a real gem ... £235. EME 23/24cm interdigital FILTERS, 3 and 5-pole ... £55 each. Tokyo HYPower 23/24cm PA, up to 50W conservative (uses Mitsubishi modules) 1W/10W in, metered power/SWR ... £450. Panasonic A1 video CAMERA with mains PSU (new) ... £110. JVC CX60GB 6" receiver MONITOR (mint) ... £220. Sony KX14CP1 14" Trinitron MONITOR (analogue and composite input, BNC/SCART)(mint) ... £250. Jaybeam D15/15 ANTENNA (1255 and 1296 types - as new) ... £40 each. Reflecta 1000W video camera LIGHT (new) ... £25. All other items as new. Postage at cost. Paul Chamberlain G4XHF, 9 Goffs Close, Southgate, Crawley, West Sussex, RH11 8QB. Tel: 0293 515201 home; 0622 696437 office.

Hitachi KP143K mains mono CCD CAMERA, demo use only ... £100. Baxall 2/3" Ultracon CAMERA, perfect ... £45. Cotron 1" Ultracon CAMERA, perfect ... £65. Cotron 1" Vidicon CAMERA, new tube but need attention, with circuit ... £15. Grundig FA70 1" Newvicon CAMERA, c/w 50mm f0.9 Schneider auto-iris lens ... £100. Baxall 9" mono hi-res MONITOR ... £40. Baxall DS1/6 6-way SWITCHER ... £30. Baxall DS1/2 2-way switcher ... £10. Baxall ZT5 TELEMETRY TX, 8-input switcher and control for pan & tilt, lights, zoom, aux, etc., with matching ZR4 receiver in weatherproof box ... £200 the pair. Tarcus LENS, 50mm f1.8, auto-iris ... £30. Computar LENS, 75mm f1.8, auto-iris ... £40. Computar LENS, 16mm f1.3, auto-iris ... £40. Fujinon LENS, 12.5mm f1.4, manual ... £25. Computar LENS, 17-102mm, manual zoom ... £30. Computar LENS, 18-108mm f1.6, auto-iris, power zoom ... £200. 500W and 300W infra-red ILLUMINATORS ... £40 and £50. Time lapse VIDEO RECORDER, Panasonic AG6010, not used since £200 service ... £300. External WEATHERPROOF HOUSINGS c/w demisters, various sizes, new ... £15. Tequipment S51B single beam OSCILLOSCOPE with manual ... £30. Vision Research Digiplex 4000 VIDEO MOTION DETECTOR, cost £6000, perfect ... £450. Vision Research KRAMMER, 16-inputs multi/demultiplexer ... £150. Vision Research PIXSTORE, digitally stores 2 frames ... £120. Baxall Watchman MOVEMENT DETECTOR, new ... £50. Denis Hoare, 104 The Greenway, London, NW9 5AP.

12" MONOCHROME MONITORS, composite input, metal cased, amber or green screen models available, clean and tested ... £30 each. Coaxial Dynamics THROUGHLINE WATTMETER (very similar to Bird 43 and takes Bird elements), N-type connectors and complete with 25W VHF and 10W UHF elements ... £75 ovno. All prices collect, carriage extra. Contact Frank G0CFD. Tel: 0778 423433.

Link 110 CAMERA + CCU +TV36 cable, viable, 1978, lots of spare ... £100. DIASCOPE (Watson) for Marconi Mk.3 complete with slide ... £35. DIASCOPE (Angenieux EPO) fit EMI 2001, complete with power supply, filters, instructions, travel case ... £45. Marconi 20 mc/s SWEEP GENERATOR, TF 10.99, 20''w 10''d 14''h ... £30. Cossor OSCILLOGRAPH model 1039M (2.75'' CRT), nice little old grey antique item plus handbook ... £75. 3 x Link Electronics QUAD VIDEO DELAY type 229. Central Dynamics Machine INTERFACE. Cox Electronics OUTPUT MODULE J113 112 111. 2 x Cox COLOUR BOX 122/024; 122/021. SOURCE IDENT generator 101. (Cox?) PAL encoded CHROMA KEY 231. various effects modules. NP Electronics TIMING MODULE/OUTPUT MODULE. Offers. Central Dynamics TIME CODE generator + handbook, SMPTE, 1974 ... £30. APERTURE CORRECTOR, EMI type 2113/1 (2001) ... £15. Rank Cintel PAL ENCODER 12522A ... £15. Dicky Howett, 23 Micawber Way, Chelmsford, Essex, CMI 4UG. Tel: 0245 441811.

Altai ROTATOR (basic model) with controller, 3-wire system, 6 months old, excellent condition, two available ... £35.00 each. Tel: Oliver 0637 880404.

Ikegami CTC350 3-tube genlockable PORTABLE CAMERA. JVC low-band U-Matic EDIT SUITE. Sony PVM 9000 9'' PAL/SECAM mains/12 volt MONITOR with audio. Panasonic NV2000 VHS C PORTABLE RECORDER. Cannon VC30 CAMERA (for above), needs working on. Link 221 VDA's, 3 in 1U rack. Tektronix 529 WAVEFORM MONITOR. Simon Gough. Tel: 0234 852789.

BATC I²C PROJECT, first 2 PCB's and most components including special genlock ICs (never got past fitting turned pin IC sockets), no reasonable offer refused. WCY/ENA SSTV unit, BW only, fitted into smart case, PCB's for colour made up but not installed. Offers around £150. Maplin RGB to PAL encoder ... £10. Craig Robinson EI3FW, Ennisree, Templecarrig, Delgany, Co. Wicklow, Eire. Tel UK-EI direct: 010 353 1 2877366.

JVC TU-26EK TUNER ADAPTOR ... £20. 9'' Hitachi B&W MONITOR model VM 906 EK ... £25. Brand new 9'' computer MONITOR with Bull composite video adaptor board ... £15. Thomson B&W CAMERA, ex Telecine, minus lens ... £10. Pair AKG K60 HEADPHONES ... £5. Rediffusion PREOMAT unit, half finished project for sensitive VHF/UHF tuner, video/audio out, with notes ... £15. CONVERTER UNIT C-mount to Nikon lens ... £10. Prefer buyer collects. Hugh Malvern. Tel: 0684 573977.

LINK 110 3-TUBE STUDIO CAMERA with viewfinder, Varatol 30 ens with 2 times extender control, CCU, cable, in basic working order but will need tidying up ... £175. Second Link CAMERA similar to above but needing more work ... offers. Tektronix 526 PAL VECTORSCOPE in working order with manual ... £75. U-Matic PORTABLE, low band JVC CR4700E with service manual, will need attention ... £65 ono. Philips LDK5 3-tube BROADCAST COLOUR CAMERA with viewfinder, 30:1 Schneider zoom lens, reception unit, surveillance unit and power supply. This camera will operate on triax or camera cable (no cable supplied) and will stand alone or Genlock (sync lock). The camera is in basic working order but has some parts missing which you will have to make, will need some tidying up ... £150. P.White. Tel: 081 847 3995 office; 0628 21718 evenings.

EXCHANGE & WANTED

WANTED: Ronford or similar metal tripod legs, with 100mm bowl. Motorola P210 walkie-talkie. John Baird letters, etc. Piers Bedford. Tel: 081 747 0069.

WANTED: Head assembly for Toshiba V-8600B Beta VCR - cheap! On offer/exchange: Sony HVT-3000UB Film Video Adaptor, Jessup Zoom Slide duplicator, Grundig VIF-K1 remote/transmitter kit. All boxed. Ken Domminey. Tel: 0323 500174.

WANTED: Circuit Diagram and any modifications for Connexions SRE90R Satellite Receiver. Any photocopy/postage costs refunded. Tel: Oliver 0637 880404.

WANTED: I.O Camera channel, ex-broadcast, also lenses TV 88 fitting. Camera cue-light domes, logos, TV station ident badges, bits that fall off TV cameras and hence make restoration problematic. Anything to offer please contact Dicky Howett, 23 Micawber Way, Chelmsford, Essex, CM1 4UG. Tel: 0245 441811.

WANTED: Help please with information on Superjack 2+ dish actuator type JARL-3618 re instructions/factory setting of limits, expenses met. Ken Domminey, 7 Chestnut Close, Eastbourne, East Sussex, BN22 0SZ. Tel: 0323 500174.

WANTED: Sony Betamax VCR's model SL-C9UB or SL-F1UB, also Sony PCM unit model PCM 701 ES. Hugh Malvern. Tel: 0684 573977.

WANTED: Information - I have a Tandata Prestel/Viewdata adaptor that behaves as intended, i.e: requests the Prestel phone number be dialled, but unless connected to a phone line will do nothing else. I would like to use it as a keyboard-controlled caption generator. Can anyone help? John Cronk GW3MEO, 2 Mostyn Avenue, Prestatyn, LL19 9NF. Tel: 0745 888355.

WANTED: Information and/or circuit diagrams for Connexions CX-2450R Satellite Receiver. I intend to use it for 24cm, so any help would be appreciated. Also, circuit diagrams for a Sony B&W camera model AVC-3250CE and matching monitor/viewfinder AVF-3250CE. All reasonable costs reimbursed. Please contact Frank Dimmock G0CFD, 13 Stephenson Way, Bourne, Lincs., PE10 9DA. Tel: 0778 423433.

KM PUBLICATIONS

CAD & DESIGN SOFTWARE (PC):

'PUFF' with Handbook (Caltech)	£ 15.00
Motorola/SM6MOM-W6 PUFF supplement	£ 11.00
Siemens S-parameters	£ 9.50
Philips S-parameters	£ 14.50
HP AppCad/HP	£ 16.50

P&P please add £1.50 for U.K.,
£2.50 for Overseas surface, £7.50 for Air Mail

KM Publications, 5 Ware Orchard, Barby, Nr.Rugby, CV23 8UF
Telephone: 0788 890365 * Fax: 0788 891883



CONVENTION 92

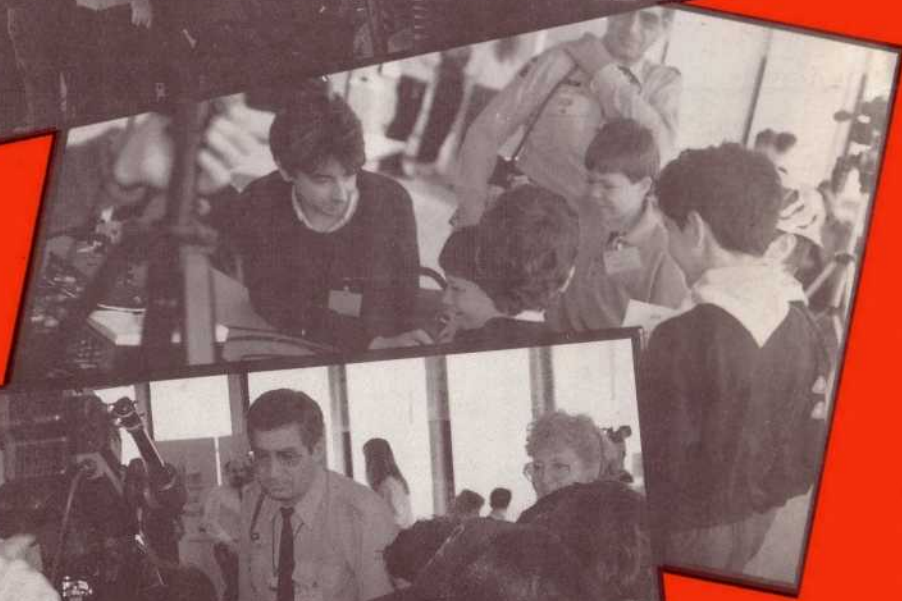

HOME COUNTIES TV GROUP AT JOTA 92