



The British Amateur Television Club

# CQ-TV

RB-TV Special - May 2015

## New Band, New Mode, New Award...

### Reduced Bandwidth TV is here!

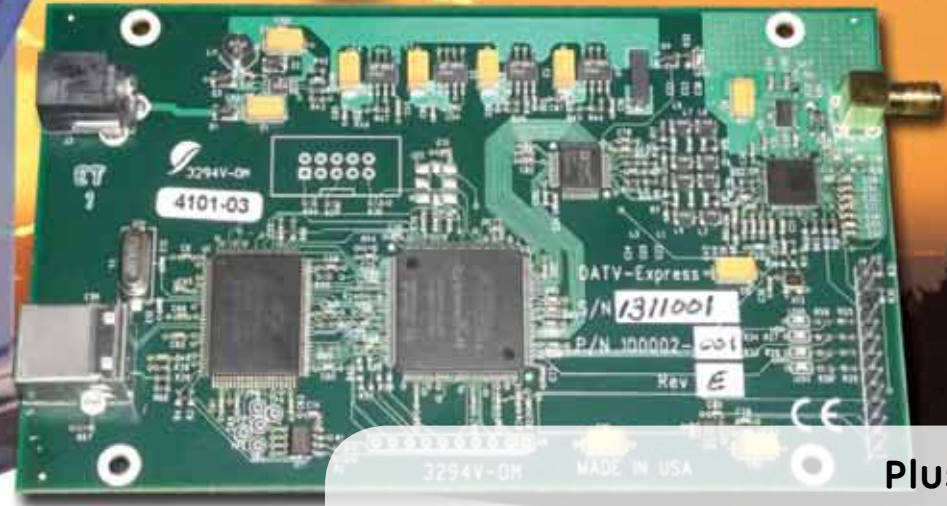

Plus...

- Reduced Bandwidth DATV (RB-TV)
- RB-TV Awards Programme
- A Two way on 146.5MHz RB-DATV
- DigiThin - A Narrowband QPSK Modulator for the Raspberry Pi
- DigiThin Beta Testing

**Ofcom**

WIRELESS TELEGRAPHY ACT 2006  
 VARIATION OF AMATEUR RADIO (FULL) LICENCE FOR THE PURPOSE OF  
 OPERATING BETWEEN 146 MHz AND 147 MHz

1. Introduction  
 Ofcom, in exercise of the power conferred by Schedule 1, paragraph 6 of the Wireless Telegraphy Act 2006 (as amended, "the Act"), hereby varies the Amateur Radio (Full) Licence ("the Licence") identified below, in accordance with Schedule 1, paragraph 7 of the Act, as detailed below.

Name of Licensee: \_\_\_\_\_

Licensee's main station address: \_\_\_\_\_



**President:** Peter Blakeborough, G3PYB  
**Email:** president@batc.org.uk

**Chairman:** Noel Matthews, G8GTZ  
 Club affairs and Technical queries.  
 ETCC Liason.  
**Email:** chairperson@batc.org.uk

**General Secretary:** David Mann, G8ADM  
 General club correspondence and business.  
**Email:** secretary@batc.org.uk

**Shop/Members Services:** Noel Matthews, G8GTZ  
**Email:** shop@batc.org.uk

**Hon. Treasurer:** Brian Summers, G8GQS  
 Enquiries about club finances, donations, Club  
 Constitution.  
**Email:** treasurer@batc.org.uk

**Contests:** Dave Crump, G8GKQ  
**Email:** contests@batc.org.uk

**CQ-TV Editor:** Frank Heritage, M0AEU  
**Email:** editor@batc.org.uk

**CQ-TV Advertising:** David Mann, G8ADM  
**Email:** adman@batc.org.uk

**BATC Webmaster:** Noel Matthews, G8GTZ  
 Anything to do with the BATC web sites.  
**Email:** webmaster@batc.org.uk

**Repeaters:** Clive Reynolds, G3GJA

**Membership:** David Mann, G8ADM  
 All membership enquiries including new applications,  
 current membership, non receipt of CQ-TV,  
 subscriptions.  
**Email:** memsec@batc.org.uk

**Club Liaison:** Graham Shirville, G3VZV  
 Anything of a political nature.  
**Email:** g3vzv@amsat.org

# CQ-TV magazine RB-TV Special

## Contents:

- 3 Spectrum Matters
- 4 Reduced Bandwidth DATV (RB-TV)
- 8 RB-TV Awards Programme
- 9 DigiThin - A Narrowband QPSK Modulator for the Raspberry Pi
- 12 A Two way on 146.5MHz RB-DATV
- 14 STOP PRESS! Ofcom release 70 MHz spectrum for digital experimentation
- 15 DigiThin Beta Testing

### Legal Niceties (the small print)

E&OE. Whilst every care is taken in the production of this publication, the editor accepts no legal responsibility for the advice, data and opinions expressed. The BATC neither endorses nor is it responsible for the content of advertisements or the activities of those advertisers. No guarantee of accuracy is implied or given for the material herein.

The BATC expressly disclaims all liability to any person in respect of anything and in respect of the consequences of anything done or omitted to be done wholly or partly in reliance upon the whole or any part of this magazine. As the regulations for the operation of radio frequency equipment vary in different countries, readers are advised to check that building or operating any piece of equipment described in CQ-TV will not contravene the rules that apply in their own country. The contents of this publication are covered by international copyright and must not be reproduced without permission, although an exception is made for not-for-profit publications (only) wishing to reprint short extracts or single articles and then only if acknowledgment is given to CQ-TV. Apart from any fair dealing for the purposes of published review, private study or research permitted under applicable copyright legislation, no part of this publication may be reproduced, stored in a retrieval system or transmitted in any form or by any means, electronic, mechanical, photocopy, recording or otherwise, without the prior permission of the publisher.

All copyrights and trademarks mentioned in this publication are acknowledged and no infringement of the intellectual copyright of others is intended.

Printed in Great Britain. ISSN 1466-6790

© Copyright BATC & Contributors 2014

## Contributions

The preferred method of communication is by email, all email addresses are shown above.

You can also telephone 01400 414 243  
 You will then hear a menu that will allow you to be connected to the correct person if they are available.

Alternatively you can write to us at:  
 BATC, Silverwood, South View Road, Pinner,  
 HA5 3YA, United Kingdom

We aim to publish CQ-TV quarterly in  
 March, June, September and December.

The deadlines for each issue are:  
 March - Please submit by January 31st  
 June - Please submit by April 30th  
 September - Please submit by July 31st  
 December - Please submit October 31st

Please send your contributions in as soon as you can prior to this date. Don't wait for the deadline if you have something to publish as the longer we have your article, the easier it is for us to prepare the page layouts. If you have pictures that you want including in your article, please send them, in the highest possible quality, as separate files. Pictures already embedded in a page are difficult to extract at high quality but if you want to demonstrate your preferred layout, a sample of your finished work with pictures in place is welcomed. Please note the implications of submitting an article which are detailed on the contents page.





# Spectrum Matters

Noel Matthews - G8GTZ

*A lot has been happening in the world of spectrum and the BATC continues to be involved in discussions with RSGB, Ofcom, CAA and IARU to ensure the ATV community's interests were represented.*

Firstly, the formal minutes of the IARU region 1 conference which was covered in the previous CQ-TV have been released confirming use of 436 DATV – see separate report by G3VZV following this article.

Then in October we received the news that full licensees could apply for a 1 year NoV to operate in the 146 – 147 MHz sub band. Of particular interest to ATVers is the quote from the RSGB FAQ:

*“Ofcom’s view was that they were not keen on allocating additional VHF spectrum to Amateur radio for ‘more of the same’. As the RSGB case was that we needed some additional spectrum for amateurs to experiment and test new digital communications schemes and systems, there will not be any 146 – 147 MHz band plan allocation for CW, SSB, FM or AFSK data.*

In fact, through negotiations by the BATC with the RSGB VHF manager a 500 KHz sub segment of the new band has been put aside for NB DATV and data applications – this slide from G4SWX at the RSGB convention shows the proposed plan:

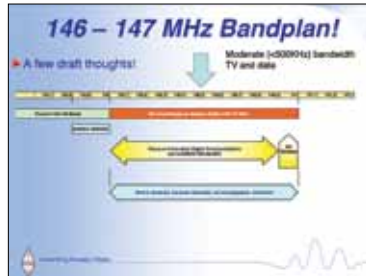

And the finalised band plan available from the RSGB website shows the following allocations. ... but see note 1.

► The 146Mhz NoV is not available in some areas of the UK. The shaded locators show the extent of the limitations.

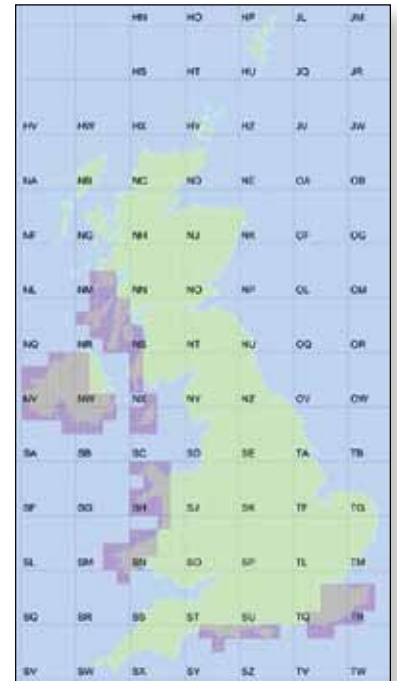

And then in November Ofcom announced the allocation of 2300 – 2302 MHz and from November 2014, NoVs are available to access this frequency range for a three year period from fixed

locations. Once again BATC has been in discussion with the RSGB spectrum manager and there is the potential of an allocation of a sub band to be used for very narrow band (sub 1 MHz wide) DATV.

A common theme in all the spectrum news is that there are new opportunities for the ATV community but we will need to adopt narrow band techniques to take full advantage and the BATC is supporting the new initiatives to develop

very narrow band RB-TV equipment using MPEG-4. – see article in this issue of CQ-TV. 📺

146-147MHz	Necessary Bandwidth	UK Usage
146.000-146.900	500kHz	<b>Wideband Digital Modes</b> (High speed data , DATV etc) 146.500 MHz Centre frequency for wideband modes (Note 1)
146.900-147.000	12kHz	<b>Narrowband Digital Modes including Digital Voice</b> 146.9000 146.9125 146.9250 146.9375 <b>Not available in/near Scotland</b> (see Licence Notes & NoV terms) 146.9500 146.9625 146.9750 146.9875

# Reduced Bandwidth DATV (RB-TV)

## The next generation DATV

Noel Matthews - G8GTZ

*The allocation of spectrum for very narrow band or Reduced Bandwidth DATV (RB-TV) within the new 146 MHz band in the UK and the increasing interest in using RB-TV on other bands has triggered several projects to develop the second generation of equipment for amateur use.*

The common aim of these projects is to produce fast scan amateur television equipment which will allow operation in less than 1 MHz of bandwidth whilst still producing acceptable picture quality. This article describes the various projects which are in development and tries to lay out the possible options for operators to get on air with RB-TV.

### DATV Transmission elements

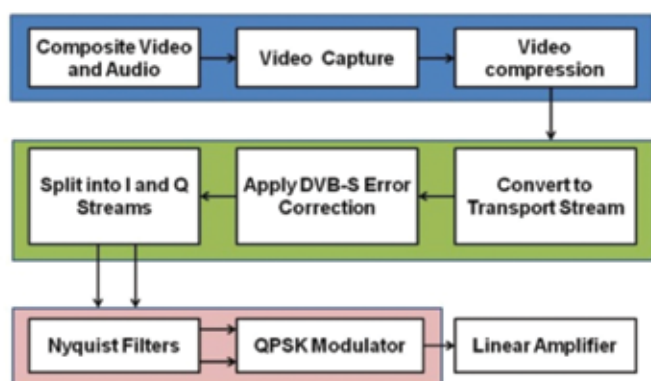

The need to reduce the transmitted bandwidth below 1 MHz impacts on several areas of DATV equipment design and in particular the need for more efficient video coding. The common consensus is that MPEG-2 is unusable below 1 Mbit/s and that we will have to adopt H264 (MPEG-4) coding to achieve the desired quality. Also, to achieve the really low symbol rates required the Nyquist filters in the current range of I&Q modulators such as Digilite and DATV-Express will need to be modified.

Whilst most modern consumer STBs will decode H264, most models are only specified to operate down to .8 – 1 Ms/s (Msymbols per second) so new receiver solutions are required and this is proving to be the most difficult technical challenge to solve.

### Is H264 good enough?

Brian, G4EWJ, and Jean Pierre, F6DZP, have done some excellent work evaluating the performance of H264 at very low bit rates.

Brian has produced a number of test videos at various frame and bit rates which he showed at CAT14 and are available for download at: <https://www.dropbox.com/sh/beyc5kl1d2qyju7n/AACaa02tsHP6y2cVYU9pwhRka?dl=0>

F6DZP has examples of the video quality that can be achieved at very low Symbol Rate using DVB-S on his web site at <http://www.vivadatv.org/viewtopic.php?f=72&t=332>

In particular, there is a recording of his signals using QPSK at 250 kS/s and received by Tutoune software <http://www.vivadatv.org/images/test%20250kS%20extrait.html>

The results are very subjective and depend on personal preferences but seem to indicate that H264 does produce acceptable results at rates as low as 200 Kbit/s.

### H264 encoding options

Current amateur DATV equipment produces MPEG-2, either by a dedicated encoder such as ex-broadcast equipment or by utilising custom chips as used in the SR systems equipment and the DTX1. The Digilite systems use a Hauppauge capture card such as the PVR150 to do MPEG-2 encoding prior to PC processing. Unfortunately these systems are unable to produce H264 and we must look for new solutions.

The PVR150 in current Digilite systems could be replaced with the HD-PVR which is H264 capable but may not encode at really low bitrates.

It is possible to encode video at low data rates in H264 in software using a standard PC / Linux system. F6DZP has done a lot of work evaluating the options and further details are available on the BATC forum: <http://www.batc.org.uk/forum/viewtopic.php?f=71&t=1128>

However, finding suitable cheap reliable composite video input capture devices for PC / Linux platforms is becoming a major problem. For example, the Pinnacle Dazzle DC100 works well on Windows 7 but is not supported on Windows 8.1 and the EzCap devices are a minefield as there are a many types of clones using various cheap chipsets and the most common chipset is not supported by Linux. So maybe it is time we moved away from composite video in the shack and started using a webcam or DV camera where no additional capture hardware is required.

## RPiDATV

Whilst it is possible to use a PC for H264 encoding, most ATV operators prefer to use dedicated hardware for their ATV station, particularly when out portable. With this in mind, Evariste F5OEO, has developed RPiDATV software for the Raspberry Pi to enable an H264 encoded stream to be generated, either from a TS file on the SD card or from the internal RPi camera for live video. The I/Q data can be taken directly from the GPIO pins on the RPi and used to drive an I/Q modulator such as the Digilite PCB – see below.



### F5OEO – UglyDATV for the RPi

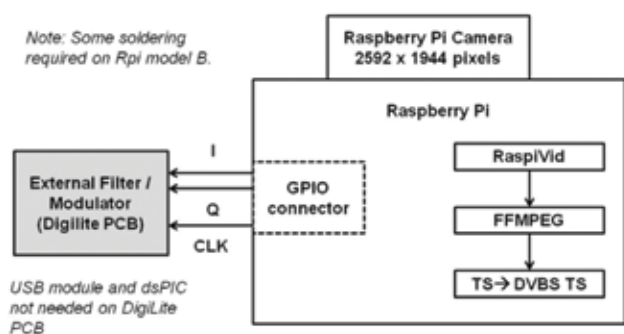

A separate article in this issue of CQ-TV describes this software and includes details on how 437.5 MHz and 23cms DATV can be generated directly by the RPi, although it must be noted that this is for testing purposes only and should never be used “on air” as the design does not incorporate any Nyquist filtering.

### The Digithin modulator card for the RPi

A related development by G4EWJ was described at CAT14 – Brian is developing a plug in card for the Raspberry Pi called Digithin. The RPi would run the RPiDATV software to generate I/Q data and clock on the GPIO port which is fed on to a plug in card containing a modulator / serialiser device. This will process the data

### DigiThin Block Diagram

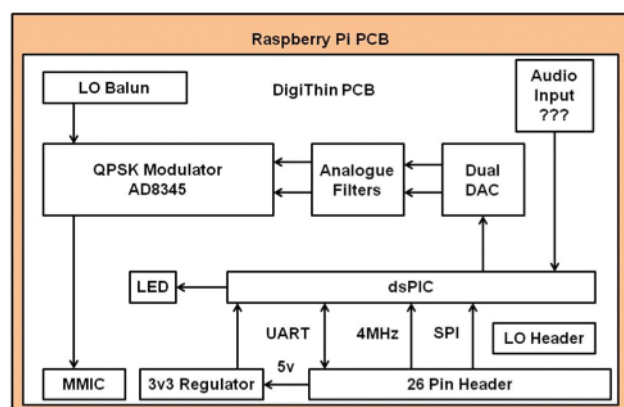

and, using an external local oscillator source, generate the RF. Coupled with a lithium battery, the idea is to make a completely self contained, portable, narrowband DATV transmitter for 146MHz or 437MHz.

Digital filtering of the IQ data will maintain the narrow bandwidth of the RF. The IQ filter roll off for DVB-S is 0.35, using the rule of thumb to be 60dB down at 1.35 times the symbol rate 333k symbols / second at the moment will give a bandwidth of about 450kHz. A full article describing Digithin will be included in a future CQ-TV.

### Using Digilite for RB-TV

As mentioned, the capture card on a standard Digilite system would need to be replaced for an H264 compatible device such as the HD-USB. Also it is possible to take I/Q signals directly from the Raspberry Pi GPIO port and feed it in to the Digilite modulator card to produce an RB-TV signal. See the separate RPiDATV article in this CQ-TV for further details.

NYQUIST FILTER VALUES					
MB/S	C13/18	L1/1	C14/17	L2/4	C15/18
4	330pF	5.6uH	1200pF	6.8uH	330pF
	0.33nF		1.2nF		0.33nF
2	660pF	11.2uH	2400pF	13.6uH	660pF
	0.66nF		2.4nF		0.66nF
1.3333	990pF	16.8uH	3600pF	20.4uH	990pF
	0.99nF		3.6nF		0.99nF
1	1320pF	22.4uH	4800pF	27.2uH	1320pF
	1.32nF		4.8nF		1.32nF
0.5	2640pF	44.8uH	9600pF	54.4uH	2640pF
	2.64nF		9.6nF		2.64nF
0.25	5280pF	89.6uH	19200pF	108.8uH	5280pF
	5.28nF		19.2nF		5.28nF

Whichever video encoding method is chosen, the Nyquist filter values on the Digilite PCB will need to be changed. The following table shows possible values for the lower symbol rates when used on a version 5.9 PCB but these will need confirming before use - see the BATC forum for full details.

### RB-TV with DATV-Express

The DATV-Express is an extremely flexible DATV exciter/transmitter that will operate over a wide range of symbol rates and frequencies (70 MHz to 2.45 GHz) and is capable of doing narrow band modes.



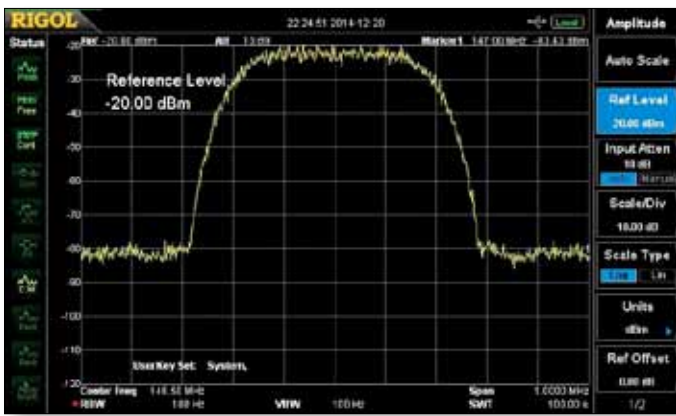

► **DATV-Express** operating at 146.5 Mhz 333KS/s 1 MHz BW

UDP Code which enables the F5OEO RPiDATV software to work with DATV-Express has been released. However, at the time of writing, the FPGA filtering needs further work to remove some aliases evident at low symbol rates. Announcements when this work is complete will be made on the project website [www.datvexpress.com](http://www.datvexpress.com)



## Receiving RB-TV

Receiving RB-TV is the hard part! DVB-S2 chipsets are only specified for a minimum symbol rate down to 1Ms/s and therefore most receivers are only guaranteed to work to that rate.

As the signal bandwidth reduces, there is some gain in analogue signal performance but we also see a reduction in MER due to timing and frequency accuracy issues. This means that even the best receivers do not work reliably below 800kS/s and some units even see degraded performance below 1.6Ms/s.

Currently, the only viable way of receiving RB-TV is by using the excellent Tutoune software by Jean-Pierre F6DZP available for download from <http://www.vivadatv.org>

Tutoune will decode H264 signals down to 250Ksymbols using either the Technotrend S2-1600 or S2-3200 cards. Frequency tuning is critical when operating at such low symbol rates and the very slow baud rate box in expert



► **The various options** - the table below shows the options for RB-TV

Video device / capture	Bit stream processing	I+Q modulator	Comments
DV camera	Linux / Windows	Digilite	DV only – no capture device required
PVR 150 or similar	Windows	DigiLite	Not H264 - unsuitable for RB-TV
USB only - PVR USB2 (v24xxx) or HVR-1900	Linux device incld MK808	DigiLite	PCR may not be completely correct. Limited PID configuration.
PVR 150 or similar	Linux device incld MK808	DATV Express	Not H264 –unsuitable for RB-TV
USB only - PVR USB2 (v24xxx) or HVR-1900	Linux (incl'd Odroid SBC)	DATV Express	RB-TV requires FPGA filter development
RPi camera	RPi	DATV express	Development UDP code only
RPi camera	RPi	DigiLite PCB	
RPi camera	RPi	DigiThin	Under development
RPi camera	RPi	RPi direct RF - F5OEO	For testing only - No Nyquist filtering.

mode should be ticked when using the S3200 card. Even then performance is not as good as the S2-1600 as the receive frequency needs to be set within 40 KHz meaning it is very difficult to gain and maintain lock except when receiving a local signal.

### Spectral compatibility

RB-TV allows us to operate DATV in bands where we do not have enough bandwidth to operate conventional DVB-S and therefore it follows that we will also be operating much closer to other amateur and more importantly non-amateur services.

ATV operators are in a unique position that we still construct our own prime movers, drivers and PAs and we need to be very aware of the need for spectral purity and, particularly for digital operation, to avoid spectral re-growth. It is no longer acceptable to just use power and MER as an indication of transmitter suitability and the BATC urges all members to ensure that their equipment meets or exceeds any recommendations. The target for RB-TV should be that the total occupied bandwidth of the transmitted signals, at -65dBc measured at the transmitter output is less than 800 kHz and -50dBc should be regarded as an absolute minimum.

We realise not all members have access to suitable test equipment to measure this and if there is demand BATC will set up a register of people who have the equipment and expertise to help others in their local area.

### The future

RB-TV as described in this article is based around using MPEG transport streams as the transmission container as it has evolved from the DVB-S systems that we use today. This has been proved to work for the initial tests and will enable ATV operators to get on air quickly however, as we go down to very low symbol rates we are no longer compliant with broadcast standards. We will have to develop our own receivers and so maybe it is time we started looking at alternatives such as Internet type streaming protocols.

Indeed, there are already good reasons not to use MPEG TS at these low symbol rates as a lot of the libraries such as Gstreamer do not support Transport streams properly but they do support other containers. And as more projects such as <http://radio.testa.co> become available using IP based protocols, we may have to have completely re-think what we are doing in order for us to be able to take advantage of these developments .

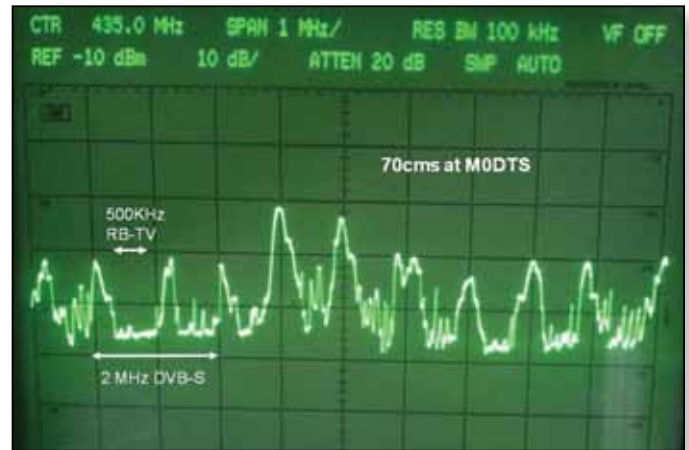

### BATC and RB-TV

The BATC is supporting the RB-TV initiatives by publishing articles on the various projects and will be stocking any hard to get components in the BATC shop. We have also decided to set up a series of awards to encourage development and activity using RB-TV. Details of these are published elsewhere in CQ-TV.

### Summary

As well as enabling ATV on the new UK 146 MHz and 2302 MHz bands and operation below 100 MHz, RB-TV has the potential to enable significant distances to be worked on all bands where wider bandwidth DVB-S would fail.

Tests on 437 MHz by 5 French stations during October 2014 have shown that contacts at 250 km or 300 km were possible everyday using 250ks/s. The same paths produced very weak analogue signals or were not possible on most days using DVB-S at 1Ms/s. A full report of these tests can be found on the vivadatv forum.

RB-TV may also make it possible to operate on 70cms in areas where it is not possible to operate the 2 MHz wide DVB-S due to interference. However, there may be sub 1 MHz slots which are relatively free from interference and RB-TV would then be useable.

There is some way to go yet before we have a standard RB-TV system but the building blocks are being put in place and we encourage you to get involved and experiment – but please remember that these projects are being run by people who also have full time jobs so progress may not be as fast as we would wish!

Further information is available on the BATC forum and the following sources:

<http://www.batc.org.uk/forum/viewtopic.php?f=15&t=3982>

<http://www.batc.org.uk/forum/viewforum.php?f=76>

# RB-TV awards programme



To encourage RB-TV development and activity the BATC is delighted to announce the following awards:

- First QSO over 10 km on the new 146 MHz band
- First QSO over 100 km on the new 146 MHz band
- First QSO over 250 km on any band
- BATC grant award for development of RB-TV receiver technologies



## Terms and conditions

- ▶ The QSO's have to be two way contacts undertaken after **1st January 2015**
- ▶ Please remember that to transmit on the 146/147MHz band requires you have obtained an NOV first! See <http://rsgb.org/main/operating/licensing-novs-visitors/online-nov-application/146mhz-147mhz-nov/> and the 25 watt power limit is erp NOT transmitter power.
- ▶ RB-TV is defined elsewhere in this edition of CQ-TV and claims for the first QSOs on the 146/147MHz band must include a declaration stating the total occupied bandwidth of the transmitted signals is less than 800kHz (or a spectrum plot could be included).
- ▶ Claims should include a full description of the equipment used for the contact.
- ▶ The first QSO Awards will be trophies which will be presented at the CAT15 Convention
- ▶ The BATC Grant Award will be a cash sum of £500 awarded to the person or people that the BATC committee think have contributed most to solving the problems of receiving NB-TV. The grant will be presented at the CAT15 Convention





# DigiThin - A Narrowband QPSK Modulator for the Raspberry Pi

Brian Jordan, G4EWJ

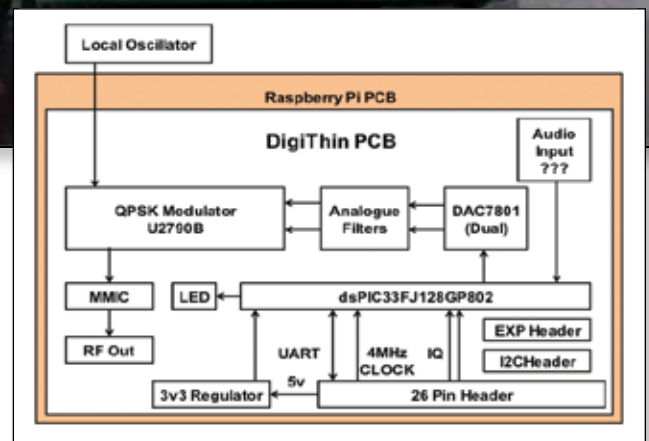
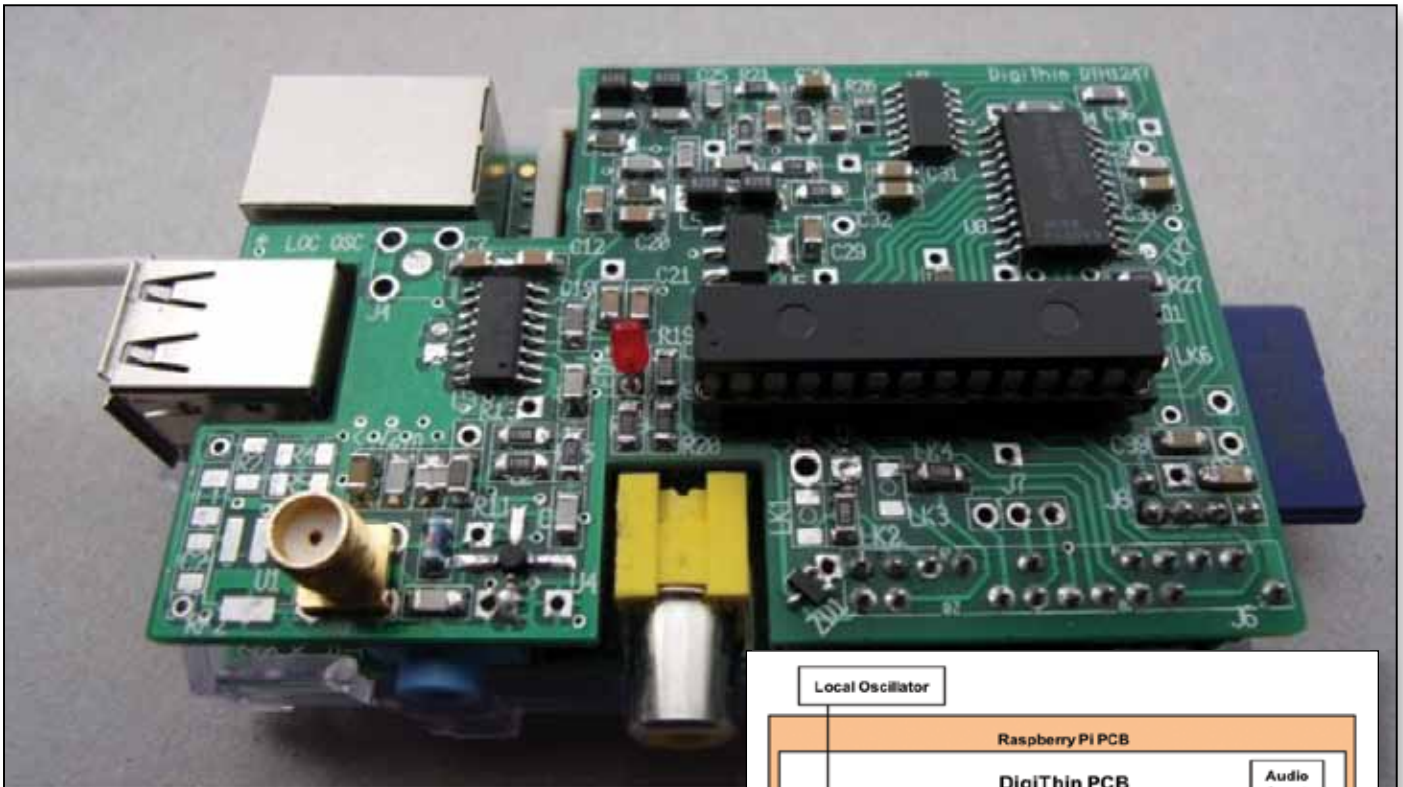

## Features and Projected Spec

- ▶ sends QPSK / MPEG-4 video from the RPi camera
- ▶ fits directly on to the model B 26 pin header
- ▶ powered from the RPi
- ▶ receives IQ signals from F5OEO's RPi software
- ▶ applies digital filtering to the IQ signals
- ▶ outputs the filtered IQ signals via a digital-analogue converter (DAC)
- ▶ modulates directly at the tx frequency
- ▶ 1mW output power
- ▶ local oscillator (LO) option, or external
- ▶ several selectable symbol rates from 111k to 333k, without any hardware changes
- ▶ I2C and input / output expansion headers
- ▶ SOIC / 1206 components for easier soldering
- ▶ audio capture may be possible

## Project Aims and Status

The main aim is to produce an RB-DATV (reduced bandwidth DATV) modulator with digital filtering, in a form that is easy to homebrew and has no adjustments. This has required some compromises. It will not have the performance of a device with more modern, but impossibly small, chips. I would have liked more time for testing and development, but the year of our 147MHz extension is ticking away. The project is not at the same level of development as DigiLite when it was launched. It is more like an advanced-stage experimental project. There will doubtless be component and maybe circuit modifications as people start to use it. It has only 333k symbols per second capability at the moment. The lower symbol rates may need slightly different filter software, but should be possible and the LO suppression needs to be improved.

## Raspberry Pi

The Raspberry Pi has advantages as a cheap platform for many applications in amateur radio. The one of most interest to us is the directly connected high definition camera and H.264 (MPEG-4) video compression in hardware. MPEG-4 is twice as efficient as the MPEG-2 which we have mostly used so far and this makes low symbol rates and low bandwidth operation possible.

F5OEO has developed software for the Raspberry Pi to convert the camera video to a transport stream which can be sent to a modulator in various ways. DigiThin uses the two bit IQ option to receive the data.

The design was started before the model B+ appeared. As it gave no performance advantage, the design was not changed. If the model 2 had come out earlier, it may have been worth changing.

## Video Quality

With video compression, there is always a trade-off between picture quality and movement, so narrow bandwidth require some compromises, but many of our TV transmissions are talking head and shack shots rather than fast motion.

Here is a link to some low symbol rate sample videos. The very low res one is 128 x 92 pixels. The RPi camera benefits from good lighting and the variation of the background should be reduced by this.

<http://tinyurl.com/Low-SR-Samples>

## Connectivity

The transport stream data is received from the RPi as pairs of bits, known as the I and Q streams. Each bit stream is running at a speed identical to the symbol rate. Each IQ pair is known as a symbol and the two bits in the symbol are transmitted simultaneously.

The I and Q streams are square wave signals, so they have to be filtered before being applied to a modulator, or the transmitted bandwidth would be enormous. The DVB-S specification requires that the IQ filter is 60dB down at 1.35 times the highest square wave frequency in the IQ signals. In comparison, the 5 pole LC filter in DigiLite is only 30dB down at 2.0 times the highest square wave frequency.

## DSP Filtering

It would be very difficult, probably impossible, to design an LC filter with the roll off as good as a digital filter. In addition, the filter requires a very specific roll off characteristic known as Nyquist or raised cosine. Digital filtering can require a lot of cpu power, but the low

symbol rates we are interested in make it possible with a modest cpu, such as the dsPIC used in DigiLite.

Digital signal processing is very strange stuff. It seems completely unintuitive as to how the equations work.

## Raised Cosine Filter Impulse Response

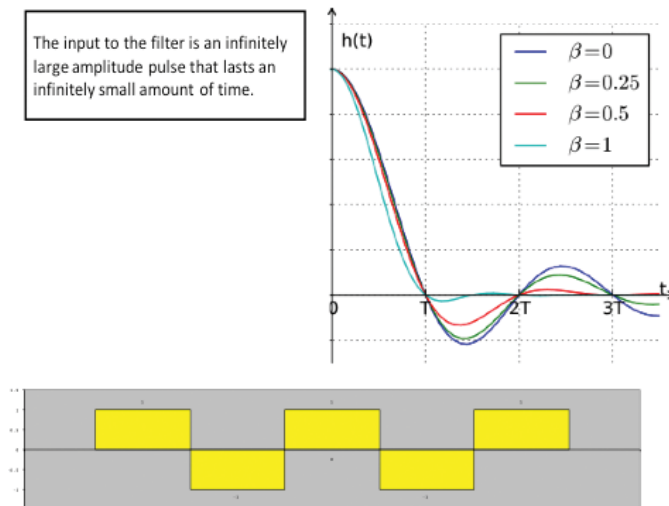

An important property of any filter is its impulse response. Basically and (I'm still trying to understand a lot of this myself) you apply an infinitely large pulse with an infinitely small width to a filter and look at what happens to the output. That tells you everything you need to know about the filter, as you can analyse its operation by splitting any input signal into a series of thin impulses and then adding the outputs generated by all the inputs. A filter can then be specified as a formula.

This leads to the surprising conclusion that any input to a filter has an effect on the output for an infinite amount of time. Any bit that is transmitted, interferes with every following bit, reducing in effect over time. This is known as ISI, inter symbol interference.

If the blocks in the diagram are the input bits (10101 in this case) and we consider that each bit consists of a single impulse at its centre, we can see that the interference caused by the middle bit is zero at the centre of all following bits. This is the useful property of the raised cosine filter. As long as we sample each bit at its centre in the receiver, there will be no interference from preceding bits.

The dsPIC on the DigiThin pcb takes the square wave IQ signals from the RPi, applies a mathematical formula to them and outputs the results to a digital to analogue converter as a shaped waveform. For 333k symbols, the DAC is updated at 4 times the symbol rate, = 1.333MHz. This is known as upsampling. Other symbol rates are upsampled by different factors so that the DAC is always updating at 1.333MHz.

Digital filter software works by generating a DAC output value arrived at by looking at as many previous input bits as possible. The higher the number of bits, the more the filter approaches the ideal width, but the higher the processing load. At 333k symbols, the initial DigiThin filter software looks back over 18 bits, upsampled by 4. This is described as a filter with 72 taps. It should be possible to increase this, perhaps to 128 taps. The more taps, the narrower the filter.

Although a digital filter does a good job, it acts in some ways like a mixer and produces spurious signals at multiples of the DAC update rate. There will be unwanted outputs around 2.666MHz, 4.000MHz etc. An analogue filter is required after the digital filter, with a roll off that starts where the digital filter finishes (at the highest symbol rate we want) and is well down by the time that the first spurious signals appear around 2.666MHz. A 5 pole LC filter achieves this.

**DAC**

The only DAC that was big enough for homebrew and could interface to the dsPIC was the DAC7801KU, which is difficult to find. It has only 12 bit resolution. 14 bits would be better. This makes the bandwidth a little wider than ideal.

**Modulator**

The U2790B QPSK modulator has self biasing inputs for LO and IQ. It can be fed with single ended signals and there are no adjustments to make. This makes it easier to interface to than the AD8345, which requires push-pull signals. It also has the advantage of having 1.27mm pin spacing rather than 0.65mm.

The output of modulator goes through a 6db attenuator and into an SGA-3586 MMIC which has a gain of 25dB, giving an output of around 1-2dBm, about 10dB below the 1 compression point for the MMIC, for good linearity.

One advantage of upsampling the digital filter input bits is that as long as the DAC update rate of 1.333MHz is kept the same, which it has to be because the analogue filter which follows it is specifically for that rate, we can use any symbol rate where the symbol rate times the upsampling factor is 1.333M. This requires different software for each symbol rate, but no hardware changes.

Symbol Rate	Upsample	DAC Update
333k	4	1.333M
266k	5	1.333M
222k	6	1.333M
190k	7	1.333M

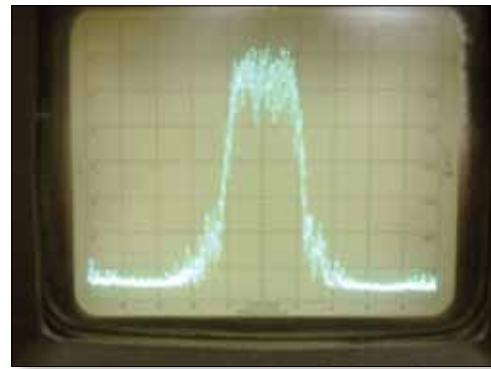

► 333k symbol, 10dB / 200kHz per div, ref -17dBm

**Local Oscillator**

The local oscillator level should be about -10dBm at the input socket. At the top left of the DigiThin pcb is a break-off section which takes an Si570 synthesiser. These come in many versions and the cheapest costs £12 and goes to 160MHz. The Si570 pcb is designed to fit under the DigiThin pcb on the J8 I2C header and be controlled directly from the RPi. The RF output is a square wave, so it may be possible to filter the 3rd harmonic and use it on 437MHz. There is a 945MHz version that costs £40. This section is still under test and it remains to be seen how much leakage there is from an unshielded oscillator so close to the modulator section.

**Reception**

Broadcast receivers generally will not work at symbol rates below 1000. The TT S2-1600 PCI card with F6DZP's Tutuone software has been the mainstay of reception so far. Unfortunately, this has just become obsolete. Investigations are continuing into a replacement. Reception of RB-DATV is a greater challenge than transmission.

**Components and Software**

The DAC has proved difficult to find at a sensible price from normal outlets, so these are being sourced from China. When they are available, a sub-kit of the pcb and major parts will be available from the BATC shop. As the software, may be subject to frequent changes, the dsPIC will not be available from the shop, so a dsPIC programmer will be required. Investigations are continuing which may enable the RPi to program the dsPIC in circuit.

The construction and software details will be available on the web at the following links. The news will be updated if any of the others are changed.

- <http://tinyurl.com/DigiThin-News-Updates>
- <http://tinyurl.com/DigiThin-Hardware>
- <http://tinyurl.com/DigiThin-dsPIC-Software>
- <http://tinyurl.com/DigiThin-RPi-Software>







# A Two way on 146.5MHz RB-DATV

Terry Roxby GILPS

Here is how with help from Rob M0DTS and Charles G4GUO I managed to get onto this new and exciting TV band.

Charles G4GUO released a new program for sending transport streams to the DATV Express, before this it was not too easy to send a low bit rate DVB rate signal but now it is possible.

Charles has also created a modified firmware file for the DATV Express FPGA to adjust filter settings allowing clean output at low symbol rate DVB-S.

Rob M0DTS released a script that automates the encoding and passing of the transport stream to the DATV Express. With the ability to change settings.

The journey to transmitting started after receiving Rob's transmission on 146.5Mhz Symbol rate 333 on Saturday 3rd of January. I was very impressed at what could be achieved on such a low band width and had to have a go.

Below you can see a screen grab of the first pictures I got from Rob. using the Tutioune software and a Techno Trend TT budget S2 1600 version card

Over a period of a couple of hours, various Tutioune settings and receive setups were tried. The two setups I settled on as being the best with equipment at hand were:

*6 element beam > Mutek preamp > Pye Europa filter > microwave modules preamp > SUP2400 > Satellite line amp > TT-1600 & Tutioune*

*6 element beam > Mutek preamp > Pye Europa filter > microwave modules preamp > sdrkits PAOKLT Si570 VCO kit > mixer > Satellite line amp > TT-1600 & Tutioune*

Both hardware configurations gave good results once some key settings were found on the Tutioune software. The new settings stabilised and made lock much easier. Although I must admit I don't as yet fully understand all the various settings.

After these setting were made we estimated we had about 8db head room with the current set-up and lock stability even with a weak constellation and low MER.

Clive G4FVP assisted by pointing his 2 meter beam at me and transmitting on the top end of 145mhz to see if it would block Rob's incoming signal. I was happy to see that lock was maintained even with Clive's strong signal in the band.



It was also great to see that the SUP2400 we all use for 70cm reception also works well for 2 meters with the TT-budget I 600 card. This card has a wider frequency coverage compared to the TT-3200 version. The SUP2400 worked better with some help after it in the form of a satellite line amplifier.

I then set about getting the equipment together for transmit and installing the software required.

Rob kindly knocked me up a couple of amplifier stages for 1 watt (see separate article) while I was playing with the software side of things and pre tuned them for the -60db shoulder limit to give me a good starting point "Thanks Rob".

The two amplification stages comprise of an RD06HVF1 and RD15HVF1 to get from the -10dBm input signal to



around 1 Watt level with -60dBc IMD products as per the recommendations.

The first two way attempt took place as soon as I was ready to transmit and could comply with the

guidance. Even though the wind was howling we both crept the antennas up a little to try a contact. This was on the 11/01/15 and the exchange was made over the 28km path. Using 1 Watt.

The next 146.5Mhz session test took place on the 13th of January and we had about 20db head room on the signals with masts fully up at both ends. As a test I gradually reduced power to below 100mw and Rob was still receiving with no issues. Rob's RX chain is a similar one to mine but looked a little more sensitive. I suspect it may be down to my filter being slightly off tune.

**Rob's setup:**

9 element beam > preamp > Pye Europa filter > preamp > Glencom vc510 mixer > TT-I 600 or TT3200 & Tutioune



▶ GILPS as received at MODTS

Comparing the Technotrend I 600 and 3200 versions of the card during the low power weak transmissions showed very little difference between them. It was very much "swings and roundabouts" which one was preferred. We have not tested lower symbol rates yet where the I 600 card may have an advantage as others suggest. The two cards do report quite different MER when the bit error rates are reporting very similar results.



▶ The screen grab shows the comparison Top is the TT-I 600 and bottom the TT-3200.

There is however new Tutioune software being developed for the TT-I 600 card that is reported as giving much better results allowing fast lock even under QSB. The two cards use different chip sets. A copy of the new software is kindly being sent to us to try.

The TX systems used at both ends were similar:

- ▶ PVR2 USB capture device and camera as the AV source. (Rob used two different setups here PVR350 For first tests and a Raspberry Pi also doing the encoding for the latest tests)
- ▶ Script for re-encoding a PVR's MPEG2 video into lower bit rate MPEG2 or MPEG4 is rb.sh
- ▶ ffmpeg re-encodes the video to MPEG4 video then encapsulates in a transport stream.
- ▶ express\_server software is used to send the transport stream to the DATV Express Hardware.

The DATV Express board sends a -10dBm DVB-S signal to Amplifiers which lift the output to 1W, down 5dB cable loss to a 6 element yagi (Rob used a 9 element) giving a few Watts ERP. at each end. I was using vertical polarization Rob used slant polarization.

We have lock when 8db above the noise. The new untried software is reported to lock at a lower level still and at lower SR over a 300km link to Paris on 70cm.

Since the 6/02/15 Clive G4FVP has also been receiving my 146.5mhz TV pictures. Can't wait to try more contacts as activity increases! 📡

STOP PRESS – STOP PRESS – STOP PRESS – STOP PRESS

## Ofcom release 70 MHz spectrum for digital experimentation

*This edition of CQ-TV was delayed so that we could bring you the exciting news of more spectrum specifically released for experimentation with DATV and other digital modes. The RSGB has been encouraged by the initiatives already shown by the ATV community at 146 MHz and this announcement increases the potential bands that we have access to for DATV and RB-TV experimentation. The RSGB / Ofcom release is as follows and further information will be included in the next edition of CQ-TV.*

Ofcom have agreed the use of 70.5 MHz to 71.5 MHz by radio amateurs for digital experimentation. Use will be permitted only via a Special Research Permit <http://licensing.ofcom.org.uk/binaries/spectrum/amateur-radio/apply-for-a-licence/ofw306.pdf>.

### The following conditions apply:

Access to this part of the spectrum will be authorised under a Notice of Variation, time-limited to 12 months and available to Full Licence holders only.

Ofcom will retain the right to reallocate Amateur Radio spectrum at 70.5 – 71.5MHz should there be a demand for this part of the spectrum from Business Radio and/or other or new services. In the event of this happening, Ofcom will not consult on this decision. However, Ofcom will provide Amateur Radio users with 12 months' notice

before such reassignment and this notice period will be publicised on the Ofcom website.

Amateur Radio use of this spectrum will be permitted on a non-protection, non-interference basis. Please note that if use is shown to cause interference, the spectrum will be removed with immediate effect

Permission will be subject to a geographical restriction and only granted for use in England, Northern Ireland and Wales. (There is legacy use of the spectrum by the Scottish Government which precludes licensing for Amateur Radio). 📡



► ATV aerials are getting bigger!



# DigiThin Beta Testing

Colin Watts G4KLB

*I was lucky enough to have been sent two PCBs (and a few other parts) by Brian for beta testing to see if there were any problems. This isn't a DigiThin article, just a few notes on my Beta testing experience.*

Construction was very straightforward, most parts are 1206 size so not too hard to solder (I had some 0805 parts in stock, they will just fit but recommend 1206) the ICs are also fairly easy to fit, no really close spaced pins. There are some links, pads and headers for optional items such as an extra mmic on the output and for future developments. The boards have a 'snap out' part for an optional Si570 xo that is being developed. The PCB is very strong so I cut mine out instead.

If you want the assembly to fit into a standard Pi case, the dsPIC can be soldered in, but I chose to fit an IC socket for this one. (If you use a B+ or Pi2 the board will need to be fitted above the extra USB sockets anyway). I didn't have a circuit diagram so just used the PCB overlay and parts list for assembly.



All parts fitted and plugged into the Pi, it was time to switch on. Always a nervous time, looking out for smoke and bits of track disappearing. Relieved that none of this happened a reassuring flash from the on-board LED was seen. A poke about with a finger confirmed nothing was getting too hot either.

The LED was flashing -... wait or stand by in CW, nice touch I thought.

Having previously played with Evariste's UglyDATV I had an SD card with software on already - some extra files needed to be added for this version, but after several emails and Skype sessions I had completed my Big Dummy's guide to Linux!



The parts list was for 437MHz so I used a Digilite VCO (available from the BATC Shop) and although there is a 6dB attenuator on the DigiThin PCB I needed an additional 20dB attenuator on the VCO.

The digital nyquist filter on this version is for 333Ks and the test file has a FEC of  $\frac{3}{4}$ , so I set up Tutuone with these parameters and connected my 70cm SUP2400 upconverter, switched to H264, and although there is no sound channel at present it seemed necessary to set the audio pid to 1000 before the picture appeared (video pid was 1001 as default) IT WORKS!

The next day I dug out my Si570VCO (that needed less attenuation) set it to 437MHz and it worked straight away, on a roll now - switched it to 146.5MHz and connected my global upconverter to the receive. Despite not making any changes to component values the video started to play. Fitted the 70cm SUP2400 back in and the video was still seen despite the constellations looking a complete mess, amazing.

I have since tried the Pickit3 in circuit programmer and can now update the DigiThin PIC software without removing the PIC and also fitted 1000pf capacitors in place of the 220pF capacitors on my second DigiThin, which works fine on 146.5MHz at 333Ks/S.

To summarize, I had no problems with the build - software and additions are still being developed.

**Many thanks to Brian G4EWJ and Evariste F5OEO for all their hard work and assistance.**



# The British Amateur Television Club



## The club provides the following for its members:

- ▶ A colour magazine, CQ-TV, produced for members in paper or .pdf (cyber membership) formats.
- ▶ **Web site** – where you can find our online shop stocking hard to get components, software downloads for published projects and much more.



- ▶ A **members forum** at [www.batc.org.uk/forum/](http://www.batc.org.uk/forum/) for help, information and the interchange of ideas.
- ▶ A **video streaming facility** at [www.batc.tv](http://www.batc.tv) which enables repeaters and individual members to be seen worldwide.
- ▶ An **annual Convention** held in the UK where you can meet other members, visit demonstrations and listen to lectures.
- ▶ **Meet other club members** at the BATC stand at local rallies across the country.



[www.batc.org.uk](http://www.batc.org.uk)